

Preface

Thank you for choosing FRECON developed and produced FR01 series vector control Drive.

This user manual supplies a detailed description of FR01 series vector control Drive includes product characterization, structural features, parameter setting, operation and commissioning, inspection maintenance and other contents. Be sure to carefully read through the safety precautions before use, and use this product on the premise that personnel and equipment safety is ensured.

IMPORTANT NOTES

- ◆ To illustrate the details of the products, pictures in this manual based on products with outer casing or safety cover being removed. When using this product, please be sure to well install outer casing or covering by the rules, and operating in accordance with the manual contents.
- ◆ The illustrations this manual for illustration only and may vary with different products you have ordered.
- ◆ The company is committed to continuous improvement of products, product features will continue to upgrade, the information provided is subject to change without notice.
- ◆ If you are using have questions, please contact our regional agents or our customer service center. Customer Service Tel 0755 -33067999.
- ◆ The company's other products please visit our website. <http://www.frecon.com.cn>

DIRECTORY

PREFACE	- 1 -
DIRECTORY	- 2 -
CHAPTER 1 PRODUCT INFORMATION	- 3 -
1.1 NAMEPLATE INFORMATION	- 3 -
1.2 INFORMATION OF PRODUCT MODEL	- 4 -
1.3 TECHNICAL FEATURES	- 4 -
1.4 CONFIGURATION, MOUNTING DIMENSIONS AND WEIGHT	- 6 -
CHAPTER 2 WIRING AND TERMINALS	- 9 -
2.1 WIRING WAY	- 9 -
2.2 TERMINAL CONFIGURATION	- 9 -
CHAPTER 3 WIRING AND TERMINALS	- 12 -
3.1 INSTALLATION ENVIRONMENT	- 12 -
3.2 INSTALLATION DIRECTION, SPACE AND COOLING	- 12 -
CHAPTER 4 OPERATION AND DISPLAY	- 16 -
4.1 INTRODUCTION OF KEYPAD	- 16 -
4.2 VIEWING AND MODIFYING FUNCTION CODES	- 18 -
4.3 VIEWING STATUS PARAMETERS	- 18 -
4.4 MOTOR AUTO-TUNING	- 18 -
4.5 PASSWORD SETTING	- 19 -
CHAPTER 5 LIST OF PARAMETER	- 20 -
5.1 BASIC FUNCTION PARAMETER SUMMARY TABLE	- 21 -
CHAPTER 6 MAINTENANCE AND TROUBLESHOOTING	- 46 -
APPENDIX A: MODBUS COMMUNICATION PROTOCOL	- 50 -
APPENDIX B: BRAKING RESISTORS	- 56 -

Chapter 1 Product Information

1.1 Nameplate information



Fig.1-1 Nameplate information

Model Explanation

Model show on product nameplate contains information below.

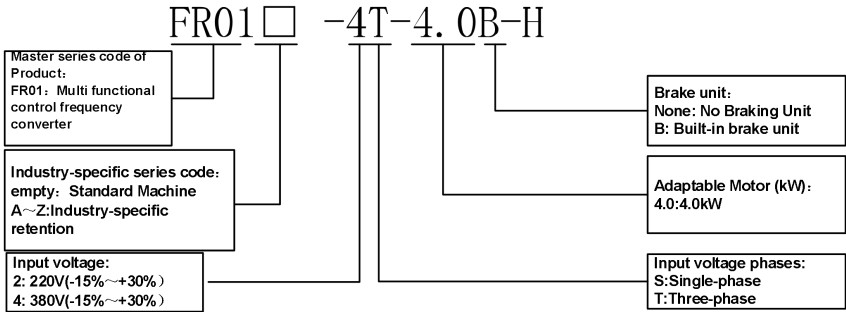

Fig.1-2 Model Explanation

1.2 Information of Product Model

Table 1-1 FR01 Product model and technical data

Model.	Power capacity KVA	Rated input current A	Rated output current(heavy load)A	Adaptive motor	
				kW	HP
Single phase:220V, 50/60Hz		Range:-15%~+20%			
FR01-2S-0.4B-H	1.0	6.5	2.5	0.37	0.5
FR01-2S-0.7B-H	1.5	9.3	4.2	0.75	1.0
FR01-2S-1.5B-H	3.0	15.7	7.5	1.5	2
FR01-2S-2.2B-H	4.0	24	9.5	2.2	3
FR01-2S-4.0B-H	6.0	30	17	4.0	5
Three phase:380V, 50/60Hz		Range:-15%~+30%			
FR01-4T-0.4B-H	1.0	2.5	1.6	0.37	0.5
FR01-4T-0.7B-H	1.5	3.4	2.5	0.75	1
FR01-4T-1.5B-H	3.0	5.0	4.2	1.5	2
FR01-4T-2.2B-H	4.0	5.8	5.5	2.2	3
FR01-4T-4.0B-H	6.0	11	9.5	3.7、4	5
FR01-4T-5.5B-H	8.9	14.6	13	5.5	7.5
FR01-4T-7.5B-H	11	20.5	17	7.5	10

1.3 Technical Features

Table 1-2 Technical features

Project		Specifications
Power input	Rated input voltage (V)	1-Phase 220V (-15%~+20%) 3-phase 380 V (-15%~+30%)
	Rated input current (A)	See table 1-1
	Rated input frequency (Hz)	50Hz/60Hz, tolerance±5%
Power output	Applicable motor(kW)	See table 1-1
	Rated output current (A)	See table 1-1
	The maximum output voltage (V)	0~rated input voltage, error<±3%
	The maximum output frequency (Hz)	0.00~590.00 Hz,unit0.01Hz
Control characteristics	V/F patterns	V/f control Sensor-less vector control 1
	Speed range	1:50 (V/f control) 1:100 (sensor-less vector control 1)
	Speed accuracy	±0.5% (V/F control) ±0.3% (sensor-less vector control 1)
	Speed fluctuation	±0.3% (sensor-less vector control 1)
	Torque response	< 10ms (sensor-less vector control 1)
Starting torque	0.5Hz: 180% (V/f control, sensor-less vector control 1)	
Basic functions	Carrier frequency	0.7kHz~12kHz

	Overload capability	G Model:150% Rated Current 60s,180% Rated Current 10s,200% Rated Current 1s.
	Torque boost	Automatic torque boost; Manual torque boost 0.1%~30.0%
	V/F Curve	Three ways: straight; multi-point type; N Th-type V / F curve (1.2 Th -type, 1.4 Th -type, 1.6 Th -type, 1.8 Th -type, 2 Th -type)
	Acceleration and deceleration Curve	Line or curve acceleration and deceleration mode. Four kinds of acceleration and deceleration time , Ramp Time Range :0.0~6000.0s
	DC brake	DC brake start frequency: 0.00~590.00Hz DC brake time:0.0s~10.0s DC brake current:0.0%~150.0%
Basic functions	Jog brake	Jog frequency range:0.00Hz~50.00Hz. Jog deceleration time: 0.0s~6000.0s.
	Simple PLC, Multi-speed	Through the built-in PLC or control terminal to achieve up to 16 speed running
	Built-in PID	Facilitate the realization of process control loop control system
	Automatic voltage adjustment (AVR)	When the grid voltage changes, can automatically maintain a constant output voltage
	Fast current limit function	Minimize over current fault protection Drive running
	Over voltage Over current	System automatically limits of current and voltage during operation to prevent frequent
Run	Command source	Given the control panel, control terminal, serial communication port given.
	Frequency given	7 kinds of frequency sources: digital setting, keyboard potentiometer setting, analog Voltage, given analog current reference pulse is given, the serial port is given, multi-speed given, PLC is given, the process PI D reference. There are several ways to switch
	Input terminal	4 Switch input terminals, one way to make high-speed pulse input. 1-channel analog inputs, including 0~10V / 0~20mA voltage and current options(F06.37),
	output terminal	1-way switch output terminal, which supports a maximum road speed 100kHz pulse output. 1 relay output terminals. 1 analog output terminal, only optional voltage
Featured functions	Parameter copy, parameter backup, flexible parameter displayed & hidden. Common DC bus (Contains below 30 KW) . Various master & auxiliary command and switchover. Reliable speed search started. A variety of Accel / Decel curves programmable. Timing control, fixed length control, count function. Three faults recorded. Over excitation brake, overvoltage stall protection programmable, under voltage stall protection programmable, restart upon power loss. Four kinds of Accel/Decel time. Motor thermal protection. Flexible fan control. Process PID control, simple PLC, 16-step speed control programmable. Wobble frequency control.	

FR01 Series Smart Inverter

	Multi-functional key programmable, field-weakening control. High-precision torque control, V/f separated control, torque control at sensor-less vector control.	
Protection function	Provide fault protection dozen: Overcurrent, Overvoltage, Undervoltage, Overtemperature, Overload Etc Protection.	
Display and keyboard	LED Display	Display Parameters
	Key lock and function selection	Realize some or all of the keys locked, scope definition section keys to prevent misuse
	Run and stop monitoring information	In the run or stop can be set to monitor U00 group four objects were.
Environment	Place of operation	Indoors, no direct sunlight, free from dust, corrosive gases, flammable gases, oil mist, water vapor, water drop and salt, etc.
	Altitude	0~2000m De-rate 1% for every 100m when the altitude is above 1000 meters
	Ambient temperature	-10℃~40℃
	Relative humidity	5~95%, no condensation
	Vibration	Less than 5.9m/s ² (0.6g)
	Storage temperature	-20℃~+70℃
Others	Efficiency	Rated power≥93%
	Installation	Wall-mounted or Flange mounting
	IP grade	IP20
	Cooling method	Fan cooled

1.4 Configuration, Mounting Dimensions and Weight

- ◆ External dimensions and wall mounting dimensions:

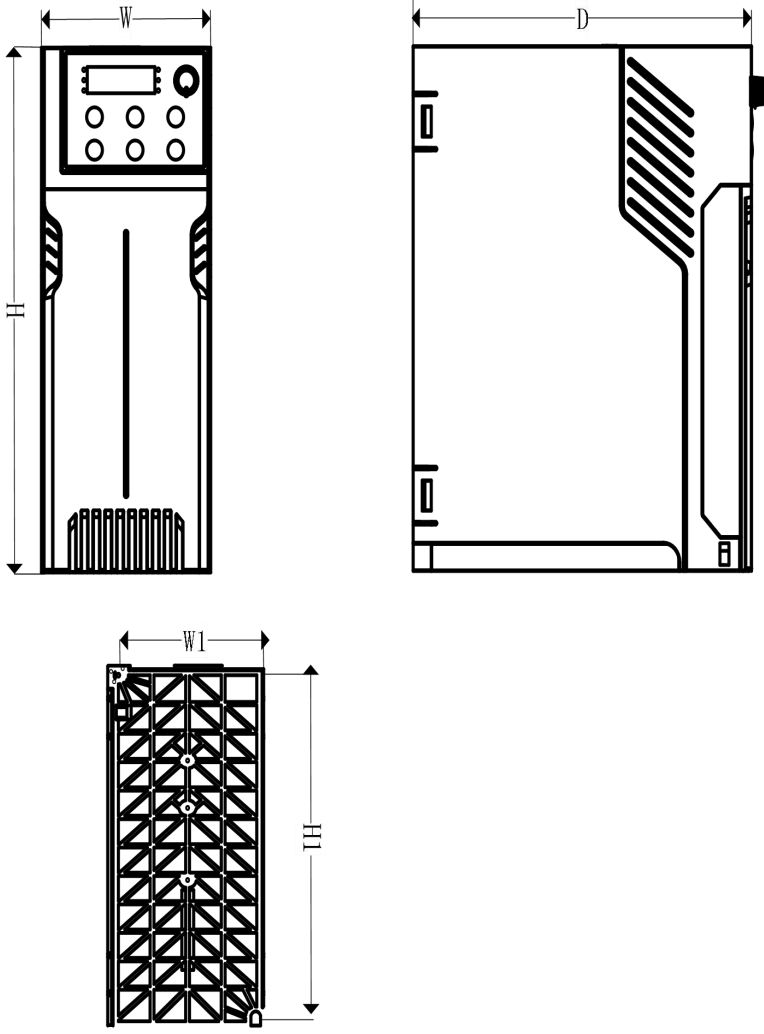

table1-3 FR01Wall installation diagram

Model	External and Install dimensions (mm)				
	W	W1	H	H1	D
FR01-2S-0.4B-H	65	56.5	170	159.5	140
FR01-2S-0.7B-H					

FR01 Series Smart Inverter

FR01-4T-0.4B-H					
FR01-4T-0.7B-H					
FR01-4T-1.5B-H					
FR01-2S-1.5B-H	75	64.5	190	179.5	150
FR01-2S-2.2B-H					
FR01-4T-2.2B-H					
FR01-4T-4.0B-H					
FR01-4T-5.5B-H	90	79	245	234.5	165
FR01-4T-7.5B-H					

Chapter 2 Wiring and Terminals

2.1 Wiring way

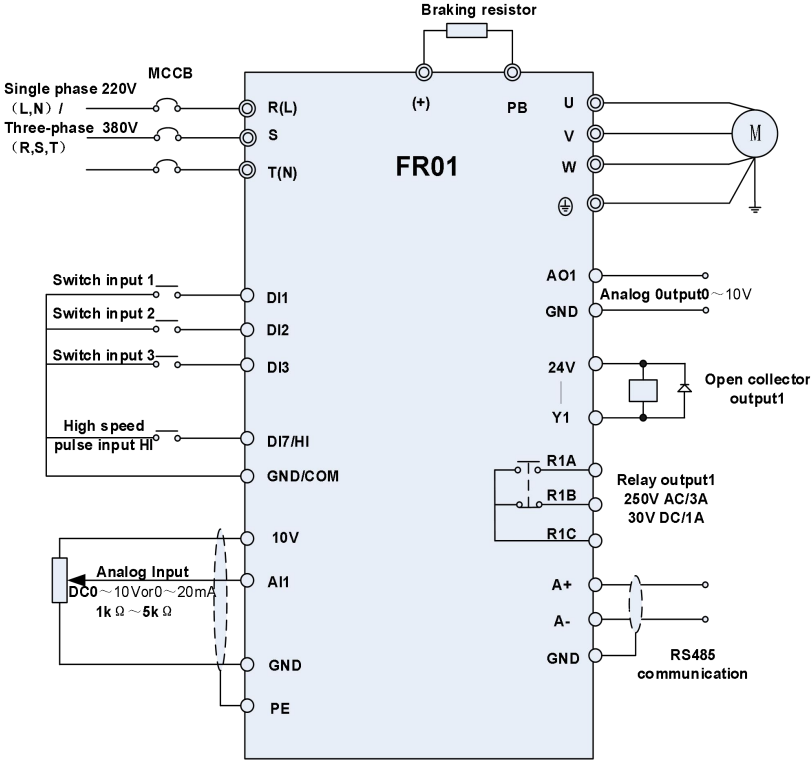

Figure 2-1 Schematic diagram of FR01 frequency converter wiring

Remarks:

- 1) Ⓞ refers to main circuit terminals., ○ refers to control circuit terminals.
- 2) User selects braking resistor based on real needs, Please refer to the braking resistor Selection Guide.
- 3) Signal cable and power cable should be separated. Try to cross control cable and power cable in 90° if needed. The best selection of analog signal lines shielded twisted pair, Power cables use shielded three-core cable(The specifications of the motor cable than ordinary freshman profile)or Comply with manual drive.

2.2 Terminal Configuration

Type	Terminal	Name	Function Description
Main Circuit Terminals			

FR01 Series Smart Inverter

Input	R、S、T	AC power input terminals for connecting to 3-phase	AC380V power supply.
	L、N	AC power input terminals for connecting to single phase	AC220V power supply.
Output	U、V、W	AC output terminals	AC output terminals of Drive for connecting to 3-phase induction motor.
	(+)	Internal DC bus positive terminal	One end connected to + and the other to PB.
	PB	Connecting terminals of braking resistor.	
		Grounding terminal.	Ground connection;
Control circuit terminals			
Power supply	10V-GND	External +10 V power supply	Provide +10 V power supply to external unit. Generally, it provides power supply to external potentiometer with resistance range of 1–5 kΩ. Maximum output current: 10 mA
	24V-COM	External +24V power supply Applying to Overvoltage Category II circuit	Provide +24 V power supply to external unit. Generally, it provides power supply to DI/Do terminals and external sensors. Maximum output current: 200 mA
Analog input	AI1-GND	Analog input 1	Input range: DC 0-10V/0-20mA, selected by function code F06.37.
Switch input	DI1-COM	Switch input 1	Maximum input frequency:200Hz Impedance:2.4kΩ Voltage range for level input:9V~30V
	DI2-COM	Switch input 2	
	DI3-COM	Switch input 3	
	DI7/HI-COM	Switch input 7orHigh-speed pulse input	Besides features of DI1–DI3, it can be used for high-speed pulse input. Maximum input frequency: 20 kHz
Analog output	AO1-GND	Analog output terminal 1	Output voltage range:DC 0~10V
Switch output	Y1-COM	Open collector output 1	Voltage range:0~24V Current range:0~50mA
Relay output	R1A-R1C	Normally open terminal	Contact driving capacity: AC250V, 3A, COSØ=0.4. DC 30V, 1A
	R1B-R1C	Normally closed terminal	
485 Communication	A+ - A-	485 Communication Terminals	Rate: 4800/9600/19200/38400/57600/115200bps Termination resistor is set by the toggle switch o

Remarks: No phase sequence requirements on wiring of the input side of Drive. Wiring

Precautions:

1) Power input terminals R, S, T

◆ The cable connection on the input side of the AC drive has no phase sequence requirement.

2) DC bus (+), (-)

◆ Terminals (+) and (-) of DC bus have residual voltage after the AC drive is switched off. After indicator CHARGE goes off, wait at least 10 minutes before touching the equipment. Otherwise, you may get electric shock.

◆ Do not connect the braking resistor directly to the DC bus. Otherwise, it may damage the AC drive and even cause fire.

3) Braking resistor connection terminals (+), PB

◆ The cable length of the braking resistor shall be less than 5 m. Otherwise, it may damage the AC drive.

4) AC drive output terminals U, V, W

◆ The capacitor or surge absorber cannot be connected to the output side of the AC drive. Otherwise, it may cause frequent AC drive fault or even damage the AC drive.

If the motor cable is too long, electrical resonance will be generated due to the impact of distributed capacitance. This will damage the motor insulation or generate higher leakage current, causing the AC drive to trip in overcurrent protection. If the motor cable is greater than 100 m long, an AC output reactor must be installed close to the AC drive.

5) Terminal  PE

◆ This terminal must be reliably connected to the main earthing conductor. Otherwise, it may cause electric shock, mal-function or even damage to the AC drive.

◆ Do not connect the earthing terminal to the neutral conductor of the power supply.

Chapter 3 Wiring and Terminals

3.1 Installation environment

- 1) Ambient temperature in the range of $-10^{\circ}\text{C} \sim 50^{\circ}\text{C}$.
- 2) Drive should be installed on surface of flame retardant object, with adequate surrounding space for heat dissipation.
- 3) Installation should be performed where vibration is less than 5.9m/s^2 (0.6g).
- 4) Avoid from moisture and direct sunlight.
- 5) Protect the cooling fan by avoiding oil, dust and metal particles;
- 6) Do not expose to an atmosphere with flammable gases, corrosive gases, explosive gases or other harmful gases.
- 7) Prevent drilling residues, wire ends and screws falling into drive.
- 8) Ventilation part of the drive should be installed outside from harsh environment (e.g. Textile facilities with fiber particles and chemical facilities filled with corrosive gases or Loaded dust cover).

3.2 Installation Direction, Space and Cooling

All the frequency converters in this series are equipped with cooling fans for forced air cooling. To ensure a good cooling circulation effect, the height direction of the frequency converter's shape after installation must be perpendicular to the ground plane, and there must be sufficient space between it and adjacent items or partitions (walls) above and below. Please refer to the following figure:

The FR01 series of compact frequency converters support both wall-mounted and rail-mounted installation.

3.2.1 Single installation

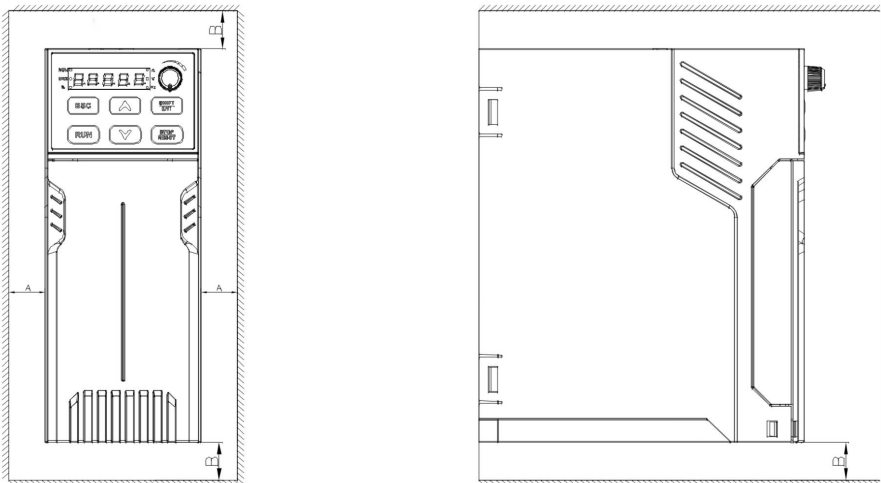

Fig.3-2 Single inverter mounting orientation and space requirements

3.2.2 Multiple installations

a. Multiple parallel installations

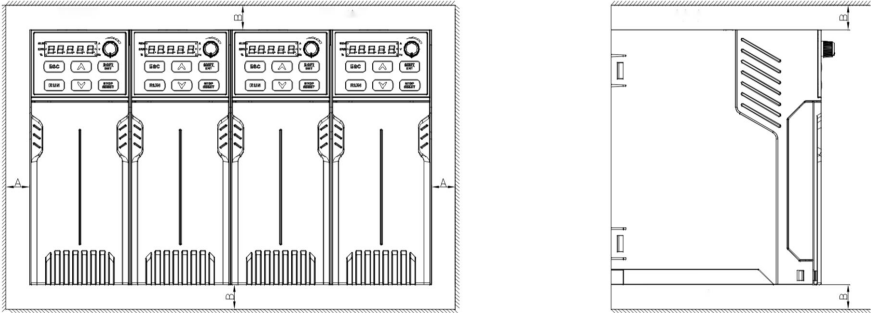

Fig.3-3 multiple inverters installed direction and space requirements

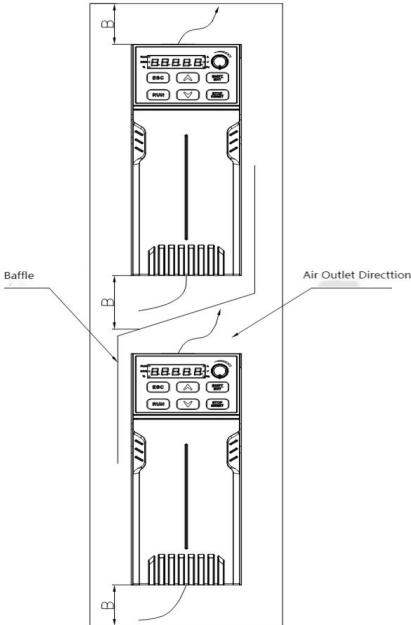

Fig.3-4 Multiple inverters installed Upper and lower mounting direction and space

Table 3-1 Requirement of minimum mounting clearances

Drive model	Mounting clearances (mm)	
	A	B
0.4~7.5kW	≥50	≥100

3.2.3 Guide rail installation

When selecting the guide rail installation, the guide rail accessories should be selected, and the customer needs to specify it specially when selecting and purchasing. The subscription code is 63.20.0686, as shown below:



Figure 3-5 Guide rail accessories (Subscription Code: 63.20.0686)

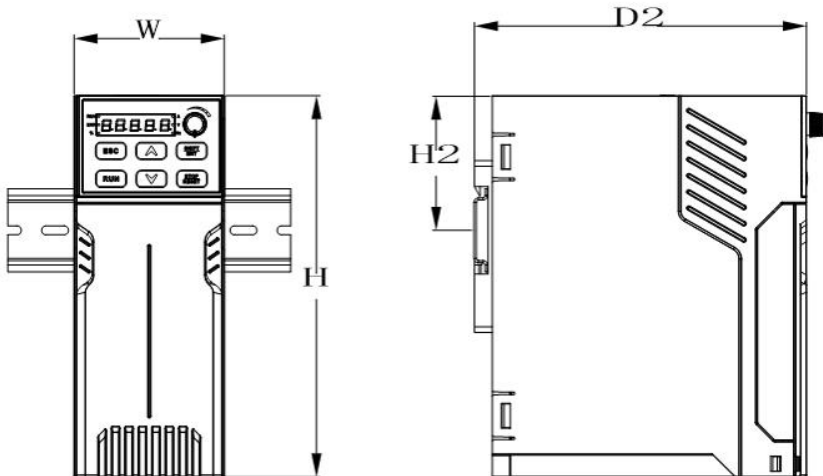

Figure 3-6 Guide rail installation dimensions

Model.	W	H	D2	H2
FR01-2S-0.4B-H	65	170	148	60
FR01-2S-0.7B-H	65	170	148	60

FR01-2S-1.5B-H	75	190	158	75
FR01-2S-2.2B-H	75	190	158	75
FR01-2S-4.0B-H	90	245	173	89
FR01-4T-0.4B-H	65	170	148	60
FR01-4T-0.7B-H	65	170	148	60
FR01-4T-1.5B-H	65	170	148	60
FR01-4T-2.2B-H	75	190	158	75
FR01-4T-4.0B-H	75	190	158	75
FR01-4T-5.5B-H	90	245	173	89
FR01-4T-7.5B-H	90	245	173	89

Chapter 4 Operation and Display

4.1 Introduction of Keypad

As a human-machine interface, you can modify the parameters, monitor the working status and start or stop the Drive by operating the keypad. Its appearance and function area as shown in the following figure:











Fig.3-1 Keypad

4.1.1 Key and potentiometer Functions on keypad

There are 8 keys and a potentiometer on the keypad, whose functions are as shown in Table 3-1.

Table 3-1 Key functions on keypad

Symbol	Name	Function
	Escape	The button to enter the first-level menu or in other menu interfaces is the exit menu button
	Shift/ENTER	Short press is the right shift button function, when the current position of the display interface flashes, press the button to shift the function, long press more than 1S for the confirmation button function, the button can enter the menu screen step by step and set parameters, keep long pressing, it will be confirmed continuously
	Increment	Increment of data or feature code
	Decrement	Decreasing data or feature codes
	potentiometer	When F01.01=1, the set frequency can be adjusted by rotating the potentiometer, which is the same function as A11
	Run	In F02.00=0, when the start-stop command source is selected as the operation panel control, press the button, and the inverter will run.
	Stop/Reset	When the running state is running, pressing this key can be used to stop the running operation; In the fault alarm state, it can be used to reset the operation, and the characteristics of this key are limited by the function code F16.01.

		Key combinations	In F02.00=0, when the start-stop command source is selected as the operation panel control, the RUN button and the STOP button are pressed at the same time, and the inverter stops freely
---	---	------------------	--

4.1.2 Keypad Indicators

There are 8 Indicators on the keypad, whose descriptions are as shown in Table 3-2.

Table 3-2 Description of indicators

Indicator	Name	Meaning
Unit	Hz	Frequency ON: currently displayed parameter is frequency
	V	Voltage ON: currently displayed parameter is voltage
	A	Current ON: currently displayed parameter is current
	%	Percentage ON: currently displayed parameter is percentage
	All off	Other unit Other unit or no unit
State	ERR	Fault state ON: Fault state OFF: Normal state Flash: Warning state
	RUN	Running state ON: Running state OFF: Stopped state Flash: In process of stop

4.1.3 Keypad digital display

The keypad has five LED (digital) display, it can display a given frequency, output frequency and other parameters, monitoring data and alarm code. Table 3-3 shows meanings of the characters displayed on Keypad.

Table 3-3 Meanings of displayed characters

Displayed character	Character Meaning	Displayed character	Character Meaning	Displayed character	Character Meaning	Displayed character	Character Meaning
0	0	A	A	I	I	S	S
1	1	b	b	J	J	T	T
2	2	C	C	K	K	t	t
3	3	c	c	L	L	U	U
4	4	d	d	N	N	u	u
5	5	E	E	n	n	y	y
6	6	F	F	o	o	-	-
7	7	G	G	p	p	8.	8.
8	8	H	H	q	q	.	.
9	9	h	h	r	r		

4.1.4 Message status

A message appears when the state of completion of certain operations. Prompt message characters and their meanings are specified in Table 3-4.

Table 3-4 Prompt characters

Prompt symbol	Meaning	Prompt symbol	Meaning
Err00~Err99	Fault type	TUNE	Motor parameter identification in

			process
A00~A99	Alarm type	-END-	Write parameter

4.2 Viewing and Modifying Function Codes

The keypad of the FR01 adopts three-level menu.

The three-level menu consists of function code group (Level I), function code (Level II), and function code setting value (level III), as shown in the figure 3-2.

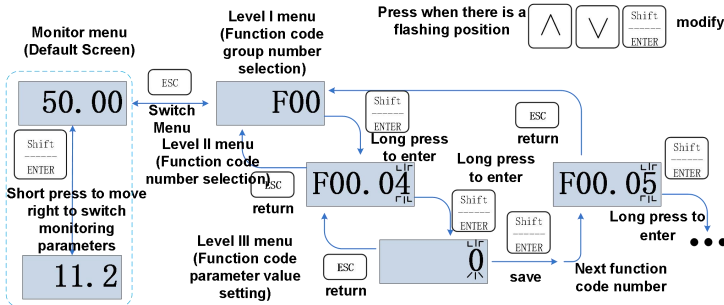

Fig.3-2 Operation procedure on the keypad

Explanation: In the level III menu, you can press the ESC key or ENT key to return to the level II menu. The difference is: If you do not have to modify the function code setting, press ENT will be automatically transferred to the next function code; If the function code settings are modified, it will display menu "-END-" 1 second when press ENT key, and redisplay the current function code settings, and it will be automatically transferred to the next function code when press the ENT key again. Press the ESC key to abandon the current parameter changes directly returns the current function code in level II.

Here is an example of changing the value of F01.02 to 15.00 Hz.

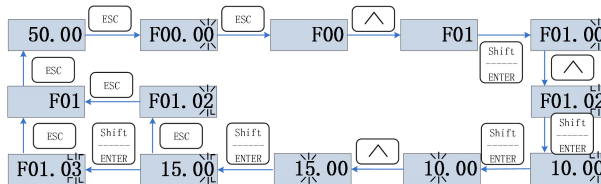

Fig.3-3 Example of changing the parameter value

In Level III menu, if the parameter has no blinking digit, it means that the parameter cannot be modified. This may be because:

- (1) Such a function code is only readable, such as, AC drive model, actually detected parameter and running record parameter.
- (2) Such a function code cannot be modified in the running state and can only be changed at stop.

4.3 Viewing Status Parameters

There are stop state parameters and running state parameters.

It has 4 status parameters in the stop or running state. You can press ">>" on the keypad to display status parameters. Which parameters are displayed is determined by the values of F16.03~F16.06 (Running state parameters 1~4), F16.07~F16.10 (stop state parameters 1~4), it can select the U00 group.

4.4 Motor Auto-tuning

Tuning is valid only when the keyboard command mode. Set tuning mode (stationary or rotating), press the ENT key to confirm, the keyboard will display TUNE, then press the RUN key, the Drive will drive motor acceleration and deceleration, positive inversion operation, and the run indicator lights. Tuning duration of about two minutes, when the display TUNE message disappears, returning to normal parameter display status, which means that the tuning is completed.

4.5 Password Setting

The Drive provides password protection function, it is set a user's password when F00.00 set to nonzero. If five minutes without operating the keypad, the password protection is effective, and the keypad will show "-----", then the user must enter the correct password to enter the regular menu, otherwise inaccessible.

There are three ways a user password into force:

Method 1: Set F00.00 parameter to nonzero, then press the ESC + ENT key.

Method 2: Set F00.00 parameter to nonzero, then do not use the keypad within five minutes.

Method 3: Set F00.00 parameter to nonzero, then completely power down and then power.

If you want to cancel the password protection functions, only through a password to enter, and set F00.00 to 0.

Chapter 5 List of Parameter

Group F00~F16 are standard function parameters. Group U00 is status monitoring parameters. Group U01 is fault record parameters.

The symbols in the function code table are described as follows:

"△" means the value of this parameter can be modified in stop and running status of drive;

"x" means the value of this parameter cannot be modified when drive is running;

"⊙" means this parameter is a measured value that cannot be modified;

Default: The value when restored to factory default. Neither measured parameter value nor recorded value will be restored.

Setting Range: the scope of setting and display of parameters

FR01 parameter groups are listed below:

Category	Parameter Group
System Parameters	F00: System Parameters
Basic Parameters	F01: Frequency Command
	F02: Start/Stop Control Start/Stop Control
	F03: Accelerate/Decelerate Parameters
Input & Output Terminals	F04: Digital Input
	F05: Digital Output
	F06: Analog and Pulse Input
	F07: Analog and Pulse Output
Motor and Control Parameters	F08: Parameters of Motor 1
	F09: V/f Control Parameters of Motor 1
	F10: Vector Control Parameters of Motor 1
Protection Parameters	F11: Protection Parameters
Application Parameters	F12: Multi-Reference and Simple PLC Function
	F13: Process PID
	F14: Swing Frequency, Fixed Length , Count and Wakeup
Communication Parameters	F15: Communication Parameters
Keys and Display of Keypad Parameters	F16: Keys and Display of Keypad Parameters
Monitoring Parameters	U00: Status monitoring
	U01: Fault record

5.1 Basic Function Parameter Summary Table

Table 5-1 Summary of Basic Functional Parameters

Param	Parameter Name	Setting Range	Default	Attr
Group F00: System Parameters				
F00.00	Setting of User Password	0~65535	0	×
F00.01	Display of Parameters	0: Display all parameters	0	×
		1: Only display F00.00, F00.01 and user-defined parameters F17.00~F17.29		
		2: Only display F00.00, F00.01, and the parameters different with factory default		
F00.02	Parameter Protection	0: All parameter programmable	0	×
		1: Only F00.02 and this parameter programmable		
		1: P type (variable torque load e.g. fan and pump)		
F00.04	Parameter Initialization	0: No operation	0	×
		1: Restore all parameters to factory default (excluding motor parameters)		
		2: Clear fault record		
		3: Back up current user parameters		
		4: Restore user backup parameters		
		5: Restore factory default. (include motor parameter)		
6: Power consumption zero clearing (U00.35)				
F00.06	Parameter editing mode	0: Editable via keypad and RS485.	0	×
		1: Editable via keypad		
		2: Editable via RS485		
F00.07	Motor selection	0: Motor 1	0	×
F00.08	Motor 1 control mode	0: V/F control	1	×
		1: Sensor-less vector control 1		
F00.09	DI7/HI input mode	0: Digital input terminal 7	0	×
		1: Pulse input		
F00.10	AI1 input mode	Unit's place: AI1 0: Analog input 1: Digital input	0	×
F00.12	PWM optimization	Unit's place: PWM modulation mode 0: Fixed carrier 1: Random carrier 2: Derating of fixed carrier 3: Derating of random carrier	501	×
		Ten's place: PWM modulation mode 0: Seven-segment mode 1: Five-segment mode 2: Five-segment and seven-segment automatic		

FR01 Series Smart Inverter

		switchover		
		Hundred's place: over-modulation coefficient 0: Invalid 1~9: 1.01~1.09 times of over-modulation		
F00.13	Carrier frequency	0.700~12.000kHz	Model defined	△
F00.14	Frequency setting (below the frequency set by this parameter, the carrier frequency is set to F00.15; above this frequency, the carrier frequency is set to F00.13)	0~20HZ	8Hz	×
F00.15	Low frequency carrier	0.700~12.000kHz	2.000kHz	×
F00.16	Output voltage	5.0~150.0%	100.0%	×
F00.17	AVR	0: Disabled	1	×
		1: Enabled		
		2: AVR is disabled if the DC bus voltage > the rated voltage of DC bus, and it will be enabled if the DC bus voltage ≤ the rated voltage of DC bus.		
F00.18	Fan control	0: Run at power-on	1	×
		1: Fan working during running		
F00.19	Factory password	0~65535	0	×
F00.20	Drive rated power	0.20~1000.0kW	Model defined	⊙
F00.21	Drive rated voltage	60~660V	Model defined	⊙
F00.22	Drive rated current	0.1~1500.0A	Model defined	⊙
F00.23	Software version	0.00~655.35	Model defined	⊙
F00.24	Dealer password	0~65536	0	×
F00.25	Run time setting	0~65536h	0h	×
Group F01: Frequency Command				
F01.00	Frequency selection source	0: Master frequency source	0	×
		1: Auxiliary frequency source		
		2: Master +Auxiliary		
		3: Master - Auxiliary		
		4: MAX{Master, Auxiliary }		
		5: MIN {Master, Auxiliary }		
F01.01	Master Frequency Command Source	0:Master digital setting (F01.02)	1	×
		1: keypad potentiometer		
		2: Analog input AI1		
		3: Communication		
		4: Multi-reference		
		5: PLC		
		6: Process PID output		
7: X7/HI pulse input				
F01.02	Master Frequency Digital	0.00~Fmax	50.00Hz	△

	setting			
F01.03	Auxiliary Frequency Command Source	0: Auxiliary digital setting (F01.04) 1: keypad potentiometer 2: Analog input AI1 3: Communication 4: Multi-reference 5: PLC 6: Process PID output 7: X7/HI pulse input	0	×
F01.04	Auxiliary frequency digital setting	0.00~Fmax	50.00Hz	△
F01.05	Auxiliary frequency range	0: Relative to maximum frequency 1: Relative to master frequency	0	×
F01.06	Auxiliary frequency coeff	0.0~150.0%	100.0%	△
F01.07	Jog frequency	0.00~Fmax	5.00Hz	△
F01.08	Maximum frequency	20.00~590.00Hz	50.00Hz	×
F01.09	Upper limit frequency	Fdown~Fmax Lower limit frequency~maximum frequency	50.00Hz	×
F01.10	Lower limit frequency	0.00~Fup	0.00Hz	×
F01.11	Operation when command frequency lower than lower limit frequency	0: Run at lower limit frequency 1: Run at 0 Hz would be activated after the time delay set by F01.12	0	×
F01.12	Lower limit frequency running time	0.0~6000.0s	60.0s	×
F01.13	Up to this frequency, start frequency compensation	0.00~590.00Hz	50.00Hz	△
F01.14	Frequency compensation per 50Hz	0.00~50.00Hz	0.00Hz	△
Group F02: Start/Stop Control				
F02.00	Run command	0: Keypad control (LED off) 1: Terminal control (LED on) 2: Communication control (LED blinking)	0	×
F02.01	Running direction	0: Forward 1: Reverse	0	△
F02.02	Reverse-proof action	0: Reverse enabled 1: Reverse disabled	0	×
F02.03	Dead time between forward and reverse	0.0~6000.0s	0.0s	×
F02.04	Start mode	Unit's place: Start Mode 0:Start directly 1:Rotational speed track and restart Ten's place: short-circuit detection function 0:Ungrounded short-circuit detection 1:Power-on short-circuit detection 2:Grounding short-circuit detection before each starts Hundred's place: Speed tracking 0:Track from zero speed 1:Track from max frequency	00000	×

FR01 Series Smart Inverter

		Thousand's place: Select if Jog function takes the priority 0: Disable 1: Enable		
		Ten thousand's place: Tracking direction 0: Last direction when stop 1: Positive direction 2: Negative direction 3: Starting direction		
F02.05	Start frequency	0.00~10.00Hz	0.00Hz	×
F02.06	Startup frequency holding time	0.0~100.0s	0.0s	×
F02.07	Startup DC braking current	0.0~150.0%	0.0%	×
F02.08	DC braking time at start	0.0~100.0s	0.0s	×
F02.09	Speed search current	0.0~180.0%	100.0%	△
F02.10	Speed search decel time	0.0~10.0s	1.0s	×
F02.11	Speed search coefficient	0.01~5.00	0.30	△
F02.12	Stop mode	0: Ramp to stop 1: Coast to stop	0	×
F02.13	Initial frequency of stop DC braking	0.01~50.00Hz	2.00Hz	×
F02.14	Stop DC braking current	0.0~150.0%	0.0%	×
F02.15	Waiting time of stop DC braking	0.0~30.0s	0.0s	×
F02.16	Stop DC braking time	0.0~30.0s	0.0s	×
F02.17	Dynamic brake	0: Disabled 1: Enabled 2: Enabled at running 3: Enabled at deceleration	0	×
F02.18	Voltage of dynamic braking	480~800V (380V) 280~400V (220V)	730V (380V) 350V (220V)	×
F02.19	Brake use ratio	5.0~100.0%	100.0%	×
F02.20	0Hz output selection	0: No voltage output 1: Voltage output	0	×
F02.21	Auto-start of power-on again	0: Invalid 1: Valid	0	△
F02.22	Waiting time between auto-start and power-on again	0.0~10.0s	0.5s	△
Group F03: Accel/Decel Parameters				
F03.00	Accel time 1	0.0~6000.0s	15.0s	△
F03.01	Decel time 1	0.0~6000.0s	15.0s	△
F03.02	Accel time 2	0.0~6000.0s	15.0s	△
F03.03	Decel time 2	0.0~6000.0s	15.0s	△
F03.04	Accel time 3	0.0~6000.0s	15.0s	△
F03.05	Decel time 3	0.0~6000.0s	15.0s	△
F03.06	Accel time 4	0.0~6000.0s	15.0s	△
F03.07	Decel time 4	0.0~6000.0s	15.0s	△
F03.08	Jog accel time	0.0~6000.0s	15.0s	△
F03.09	Jog decel time	0.0~6000.0s	15.0s	△
F03.10	Accel/Decel curve	0: Linear Accel/Decel	0	×

		1: S-curve Accel/Decel		
F03.11	Initial segment time of acceleration of S curve	0.0~6000.0s	0.0s	×
F03.12	Time unit of acceleration and deceleration	0:0.1s	0	×
		1:0.01s		
F03.13	Frequency switchover point between acceleration time 1 and acceleration time 2	0.00~Fmax	0.00Hz	×
F03.14	Frequency switchover point between deceleration time 1 and deceleration time 2	0.00~Fmax	0.00Hz	×
F03.15	End segment time of acceleration of S curve	0.0~6000.0s	0.0s	×
F03.16	Initial segment time of deceleration of S curve	0.0~6000.0s	0.0s	×
F03.17	End segment time of deceleration of S curve	0.0~6000.0s	0.0s	×
Group F04 Digital Input				
F04.00	Function of terminal DI1	00: No function	1	×
F04.01	Function of terminal DI2	01: Running forward (FWD)	2	×
F04.02	Function of terminal DI3	02: Running reverse (REV)	7	×
F04.06	Function of terminal DI7	03: Three-wire control	0	×
F04.07	Function of terminal AI1	04: JOG forward	0	×
		05: JOG reverse		
		06: Coast to stop		
		07: Fault reset (RESET)		
		08: Running suspended		
		09: External fault input		
		10: Terminal UP		
		11: Terminal DOWN		
		12: UP/DOWN (including \wedge/\vee key) adjustment clear		
		13: Multi-step frequency terminal 1		
		14: Multi-step frequency terminal 2		
		15: Multi-step frequency terminal 3		
		16: Multi-step frequency terminal 4		
		17: Accel/Decel time determinant 1		
		18: Accel/Decel time determinant 2		
		19: Accel/Decel disabled(ramp stop not inclusive)		
		20: Switch to auxiliary speed setting		
21: PLC status reset				
22: Simple PLC paused				
23: Simple PLC paused				
24: PID adjustment direction				
25: PID integration paused				
26: PID parameter switch				
27: Swing frequency pause(output the current frequency)				
28: Swing frequency reset(output the central frequency)				
29: Run command switched to keypad control				

FR01 Series Smart Inverter

		30: Run command switched to terminal control 31: Run command switched to communication control 32: Count input 33: Count clear 34: Length count 35: Length clear 36: DC brake input command at Stop 37: Speed/torque control switch 38: No reverse 39: No forward		
F04.10	Filtering time of digital input terminal	0.000~1.000s	0.010s	△
F04.11	Delay time before terminal DI1 is valid	0.0~300.0s	0.0s	△
F04.12	Delay time before terminal DI2 is valid	0.0~300.0s	0.0s	△
F04.13	Terminal DI1 ~ DI5 positive/negative logic	DI5、DI4、DI3、DI2、DI1 0: Positive logic(Terminals are on at 0V/off at 24V) 1: Negative Logic (Terminals are off at 0V/on at 24V)	00000	×
F04.14	Terminal DI6 ~ AI3 positive/negative logic	AI3、AI2、AI1、DI7、DI6 0: Positive logic 1: Negative Logic	00000	×
F04.15	FWD/REV terminal control mode	0: Two-wire mode 1 1: Two-wire mode 2 2: Three-wire mode 1 3: Three-wire mode 2 4:Pulse operation parking	0	×
F04.16	Terminal UP/DOWN frequency adjustment control	Unit's place: action when stop 0: Clear 1: Holding Ten's place: action on power loss 0: Clear 1: Holding Hundreds place: integral function 0: No integral function 1: Integral function enabled Thousand's place: Select if it can be reduced to negative frequency 0: Disable 1: Enable Ten thousand's place: Jog action to clear UP/DOWN 0: Not Clear 1: Clear	00001	×
F04.17	Terminal UP/DOWN frequency change step size	0.00~50.00Hz 0.00:Disabled	1.00Hz/200ms	△
F04.18	Terminal action selection when power on	0: Level effective 1: Edge trigger +Level effective(When power on) 2: Edge trigger +Level	0	×

		effective(Every start)		
F04.19	Delay time before terminal DI1 is invalid	0.0~300.0s	0.0s	△
F04.20	Delay time before terminal DI2 is invalid	0.0~300.0s	0.0s	△
Group F05 Digital Output				
F05.00	Y1 output function	00: No output 01: Drive is running 02: Fault output 03: Frequency-level detection FDT1 output 04: Frequency-level detection FDT2 output 05: Drive in 0Hz running 1(no output at stop) 06: Drive in 0Hz running 2(output at stop) 07: Upper limit frequency attained 08: Lower limit frequency attained 09: Frequency attained 10: Drive is ready to work 11: Drive (motor) overloaded alarm 12: Drive overheat warning 13: Current running time attained 14: Accumulative power-on time attained	1	×
F05.02	Relay 1 output function	15: Consecutive running time attained 16: PLC cycle completed 17: Set count value attained 18: Designated count value attained 19: Length attained 20: Under load alarm 21: Brake output 22: DI1 23: DI2 24: When reach the range of set frequency(FDT1) 25: Spindle orientation completion (FR510A only) 26: PID feedback loss 27: operation status (inching without output) 28: communication setting (address 2007h)	2	×
F05.04	Y1 output delay time	0.0~6000.0s	0.0s	△
F05.06	R1 output delay time	0.0~6000.0s	0.0s	△
F05.08	Enabled state of digital output	Unit's place: Y1 0: Positive logic 1: Negative logic Ten's place: Y2 (same as unit's place) Hundreds place: Relay 1 output (same as unit's place)	0000	×

FR01 Series Smart Inverter

		Thousands place: Relay 2 output (same as unit's place)		
F05.09	Detection width of frequency attained	0.00~20.00Hz	5.00Hz	×
F05.10	FDT1 upper bound	0.00~Fmax	30.00Hz	×
F05.11	FDT1 lower bound	0.00~Fmax	30.00Hz	×
F05.12	FDT2 upper bound	0.00~Fmax	30.00Hz	×
F05.13	FDT2 lower bound	0.00~Fmax	30.00Hz	×
F05.14	Consecutive running time	0.0~6000.0Min 0.0:Disabled	0.0Min	×
F05.15	Accumulative power-on time setting	0~65535h 0:Disabled	0h	×
F05.16	Accumulative running time setting	0~65535h 0:Disabled	0h	×
F05.17	Brake control selection	0: Disabled 1: Enabled	0	×
F05.18	Brake opened frequency	Closed frequency~30.00Hz	2.50Hz	×
F05.19	Brake opened current	0.0~200.0%	0.0%	△
F05.20	Brake open waiting time	0.00~10.00s	0.00s	×
F05.21	Brake open operating time	0.00~10.00s	0.50s	×
F05.22	Brake closed frequency	0.00Hz~opened frequency	2.00Hz	×
F05.23	Brake close waiting time	0.00~10.00s	0.00s	×
F05.24	Brake close operating time	0.00~10.00s	0.50s	×
Group F06 Analog and Pulse Input				
F06.00	Minimum input of curve AI1	0.0%~input of inflection point1 of curve AI1	1.0%	△
F06.01	Set value corresponding to minimum input of curve AI1	-100.0~100.0%	0.0%	△
F06.02	Input of inflection point 1 of curve AI1	Minimum input of curve AI1~Input of inflection point 2 of curve AI1	100.0%	△
F06.03	Set value corresponding to input of inflection point 1 of curve AI1	-100.0~100.0%	100.0%	△
F06.04	Input of inflection point 2 of curve AI1	Input of inflection point 1 of curve AI1~Maximum input of curve AI1	100.0%	△
F06.05	Set value corresponding to input of inflection point 2 of curve AI1	-100.0~100.0%	100.0%	△
F06.06	Maximum input of curve AI1	Input of inflection point 2 of curve AI1~100.0%	100.0%	△
F06.07	Set value corresponding to maximum input of curve AI1	-100.0~100.0%	100.0%	△
F06.24	Minimum input of curve keypad potentiometer	0.0 ~ Maximum input of curve keypad potentiometer	0.5%	△
F06.25	Set value corresponding to minimum input of curve keypad potentiometer	-100.0~100.0%	0.0%	△
F06.26	Maximum input of curve keypad potentiometer	Minimum input of curve keypad potentiometer~100.0	99.9%	△
F06.27	Set value corresponding to maximum input of curve keypad potentiometer	-100.0~100.0%	100.0%	△

F06.28	AI1 terminal filtering time	0.000~10.000s	0.100s	△
F06.29	AI2 terminal filtering time	0.000~10.000s	0.100s	△
F06.30	AI3 terminal filtering time	0.000~10.000s	0.100s	△
F06.31	Keypad potentiometer filtering time	0.000~10.000s	0.100s	△
F06.32	Minimum input of curve HI	0.00 kHz ~ Maximum input of curve HI	0.00kHz	△
F06.33	Set value corresponding to minimum input of curve HI	-100.0~100.0%	0.0%	△
F06.34	Maximum input of curve HI	Minimum input of curve HI ~ 100.00kHz	50.00kHz	△
F06.35	Set value corresponding to maximum input of curve HI	-100.0~100.0%	100.0%	△
F06.36	HI terminal filtering time	0.000~10.000s	0.100s	△
F06.37	AI1 input mode selection	0:Analog voltage input (0~10V) 1:Analog current input (0~20mA)	0	△
Group F07 Analog and Pulse Output				
F07.00	AO1 output function	00: No output 01: Output frequency 02: Command frequency 03: Output current 04: Output voltage 05: Output power 06: Bus voltage 07: +10V 08: keypad potentiometer 09: AI1 10: AI2 11: AI3 12: HI 13: Output torque 14: Ao communication given 1 15: Ao communication given 2	1	×
F07.03	AO1 offset	-100.0~100.0%	0.0%	△
F07.04	AO1 gain	-2.000~2.000	1.000	△
F07.05	AO1 filtering time	0.000~10.000s	0.000s	△
Group F08 Parameters of Motor 1				
F08.00	Motor 1 type selection	0: Three phase asynchronous motors 1: Synchronous motors 2: Single phase asynchronous motors (Remove capacity) 3: Single phase asynchronous motors (No need to remove capacity)	0	×
F08.01	Power rating of motor 1	0.1~1000.0kW	Model defined	×
F08.02	Rated voltage of motor 1	60~660V	Model defined	×
F08.03	Rated current of motor 1	0.1~1500.0A	Model defined	×
F08.04	Rated frequency of motor 1	20.00~Fmax	Model defined	×
F08.05	Rated speed of motor 1	1~30000	Model defined	×
F08.08	Stator resistance R1 of	0.001~65.535Ω	Model	×

FR01 Series Smart Inverter

	async motor 1		defined	
F08.09	Rotor resistance R2 of async motor 1	0.001~65.535Ω	Model defined	×
F08.10	Leakage inductance L1 of async motor 1	0.001~65.535mH	Model defined	×
F08.11	Mutual inductance L2 of asynchronous motor 1	0.1~6553.5mH	Model defined	×
F08.12	No-load current of async motor 1	0.1~1500.0A	Model defined	×
F08.13	Field weakening coeff 1 of async motor 1	0.0~100.0	87%	×
F08.14	Field weakening coeff 2 of async motor 1	0.0~100.0	75%	×
F08.15	Field weakening coeff 3 of async motor 1	0.0~100.0	70%	×
F08.16	PMSM stator resistance	0.001~65.535Ω	Model defined	×
F08.17	PMSM d-axis inductance	0.01~655.35mH	Model defined	×
F08.18	PMSM d-axis inductance	0.01~655.35mH	Model defined	×
F08.19	PMSM back EMF	0.1~6553.5V	Model defined	×
F08.20	Installation angle of encoder (FR510A only)	0.0~359.9°	0.0°	×
F08.21	Pole number of motor	0~1000	4	⊙
F08.30	Autotuning of motor 1	0: No autotuning 1: Static autotuning of motor 2: Rotary autotuning of motor	0	×
Group F09 V/f Control Parameters of Motor 1				
F09.00	V/f curve setting	00: Linear V/F	0	×
		01: Multi-stage V/F		
		02: 1.2nd power V/F		
		03: 1.4nd power V/F		
		04: 1.6nd power V/F		
		05: 1.8nd power V/F		
		06: 2.0nd power V/F		
		07: V/F complete separation		
		08: V/F half separation		
		09: 1.2 power inverse curve V/F		
		10: 1.4 power inverse curve V/F		
		11: 1.6 power inverse curve V/F		
		12: 1.8 power inverse curve V/F		
13: 2.0 power inverse curve V/F				
F09.01	Torque boost	0.0~30.0% 0.0%: (fixed torque boost)	0.0%	△
F09.02	Cut-off frequency of torque boost	0.00~Fmax	50.00Hz	△
F09.03	Multi-point V/F frequency 1(F1)	0.00~F09.05	0.00Hz	△
F09.04	Multi-point V/F voltage 1 (V1)	0.0~100.0	0.0%	△
F09.05	Multi-point V/F frequency 2(F2)	F09.03~F09.05	5.00Hz	△
F09.06	Multi-point V/F voltage 2 (V2)	0.0~100.0	14.0%	△

F09.07	Multi-point V/F frequency 3(F3)	F09.05~F09.09	25.00Hz	△
F09.08	Multi-point V/F voltage 3 (V3)	0.0~100.0	50.0%	△
F09.09	Multi-point V/F frequency 4(F4)	F09.07~rated motor frequency	50.00Hz	△
F09.10	Multi-point V/F voltage 4 (V4)	0.0~100.0 Ue=100.0%	100.0%	△
F09.11	V/F slip compensation gain	0.0~300.0%	80.0%	△
F09.12	Stator voltage drop compensation gain	0.0~200.0%	100.0%	△
F09.13	Excitation boost gain	0.0~200.0%	100.0%	△
F09.14	Oscillation Suppression	0.0~300.0%	100.0%	△
F09.15	Voltage source for V/F separation	0: Digital setting (F09.16)	0	×
		1: keypad potentiometer		
		2: AI1		
		3: Multi-reference		
		4: Pulse setting (DI7/HI)		
		5: PID		
		6: AI2		
		7: AI3		
	Note: 100.0% corresponds to the rated voltage of the motor			
F09.16	Voltage digital setting for V/F separation	0.0~100.0 (100.0% corresponds to the rated voltage of the motor)	0.0%	△
F09.17	Voltage rise time of V/F separation	0.0~6000.0s It indicates the time for the voltage rising from 0 V to rated Motor voltage.	0.1s	△
F09.18	Set the IQ filter time below 0.5Hz in VVF mode	F09.19~3000ms	500ms	×
F09.19	Set the IQ filter time above 2Hz in VVF mode	1ms~F09.18	100ms	×
F09.20	Torque revision when run forward	0.0~5.0%	0.0%	△
F09.21	Torque revision when run reverse	0.0~5.0%	1.0%	△
Group F10 Vector Control Parameters of Motor 1				
F10.00	Speed/torque control	0: speed control	0	×
		1: torque control		
F10.01	ASR low-speed proportional gain Kp1	0.0~100.0	15.0	△
F10.02	ASR low-speed integration time Ti1	0.001~30.000s	0.10s	△
F10.03	ASR switching frequency 1	0.00~F10.06	5.00Hz	△
F10.04	ASR high-speed proportional gain Kp2	0.0~100.0	10.0	△
F10.05	ASR high-speed integration time Ti2	0.001~30.000s	0.50s	△
F10.06	ASR switching frequency 2	F10.03~Fmax	10.00Hz	△
F10.07	ASR input filtering time	0.0~500.0ms	3.0ms	△
F10.08	ASR output filtering time	0.0~500.0ms	0.0ms	△
F10.09	Vector control slip gain	50~200%	100%	△
F10.10	Digital setting of torque	80.0~200.0%	165.0%	×

FR01 Series Smart Inverter

	upper limit in speed control mode			
F10.11	Excitation adjustment proportional gain Kp1	0.00~10.00	0.50	△
F10.12	Excitation adjustment integral gain Ti1	0.0~3000.0ms	10.0ms	△
F10.13	Torque adjustment proportional gain Kp2	0.00~10.00	0.50	△
F10.14	Torque adjustment integral gain Ti2	0.0~3000.0ms	10.0ms	△
F10.15	Excitation gain coefficient	50.0~200%	100%	△
F10.16	Torque setting source under torque control	0: Set by F10.17	0	×
		1: Keypad potentiometer		
		2: AI1		
		3: AI2		
		4: AI3		
		5: Pulse setting (DI7/HI)		
F10.16	6: Communication setting			
F10.17	Digital setting of torque	-200.0~200.0%	50.0%	△
F10.18	Forward speed limited value under torque control	0.00~Fmax	50.00Hz	△
F10.19	Reverse speed limited value under torque control	0.00~Fmax	50.00Hz	△
F10.20	Set torque accel time	0.0~6000.0s	0.0s	△
F10.21	Set torque decel time	0.0~6000.0s	0.0s	△
F10.22	Static friction torque compensation	0.0~100.0%	5.00%	△
F10.23	Static friction frequency range	0.00~20.00Hz	1.00Hz	△
F10.24	Static Frequency of Open-Loop Torque	1.00~10.00Hz	1.00Hz	△
F10.25	SVC optimization method	0: Optimized Mode 0 1: Optimized Mode 1 2: Optimized Mode 2	1	△
F10.26	Max Frequency source under torque control	0:Set by F10.18 & F10.19 1:Keypad potentiometer 2:AI1 3:AI2 4:AI3 5:Pulse setting (DI7/HI)	0	×
Group F11 Protection Parameters				
F11.00	Current limit control	0: Current limit disabled	2	×
		1: Current limit mode 1		
		2: Current limit mode 2		
F11.01	Current limit	100.0~200.0%	150.0%	×
F11.02	Frequency decreasing time(limit current in constant speed operation)	0.0~6000.0s (Mode 1 is effective)	5.0s	△
F11.03	Current limit mode 2 proportion gain	0.1~100.0%	3.0%	△
F11.04	Current limit mode 2 integral time	0.00~10.00s	10.00s	△
F11.05	Overvoltage Stall Control	0: Overvoltage stall disabled	2	×
		1: Overvoltage stall mode 1		
		2: Overvoltage stall mode 2		
F11.06	Overvoltage stall voltage	600~800V	730V	×

F11.07	Overvoltage Stall Mode 2 Proportion Gain	0.0~100.0%	50.0%	△
F11.08	Overvoltage stall mode 2 frequency limit	0.00~50.00Hz	5.00Hz	×
F11.10	Protection action 1	Unit's place: Bus undervoltage 0: Fault reported and coast to stop 1: Stop according to the stop mode 2: Fault reported but continue to run 3: Fault protection disabled	03330	×
		Ten's place: Power input phase Loss (Err09) (Same as unit's place)		
		Hundred's place: Power output phase loss(Err10) (Same as unit's place)		
		Thousand's place: Motor overload (Err11)(Same as unit's place)		
		Ten thousand's place: Drive overload(Err12) (Same as unit's place)		
F11.11	Protection action 2	External equipment fault (Err13) 0: Fault reported and coast to stop 1: Stop according to the stop mode 2: Fault reported but continue to run	00000	×
		Ten's place: EEPROM read/write fault (Err15) (Same as unit's place)		
		Hundred's place: Communication overtime error (Err18) (Same as unit's place)		
		Thousand's place: PID feedback loss (Err19) (Same as unit's place)		
		Ten thousand's place: Continuous running time reached (Err20) (Same as unit's place)		
F11.12	Protection action 3	Unit's place: Module temperature detection disconnection (Err24) 0: Fault reported and coast to stop 1: Stop according to the stop mode 2: Fault reported but continue to run 3: Fault protection disabled	00030	×
		Ten's place: Load becoming 0 (Err25) (Same as unit's place)		
		百位:reserve		
		千位:reserve		
		万位:reserve		
F11.14	Frequency selection for	0: Current running frequency	1	×

FR01 Series Smart Inverter

	continuing to run upon fault	1: Set frequency 2: Frequency upper limit 3: Frequency lower limit 4: Backup frequency upon abnormality		
F11.15	Backup frequency upon abnormality	0.00~Fmax	0.00Hz	×
F11.17	Motor overload protection time	30.0~300.0s	60.0s	×
F11.18	Overload alarm	Unit's place: detection option: 0: Always detect 1: Detect at constant speed only Ten's place: compared object 0: Rated current of motor 1: Rated current of drive Hundred's place: Fault reported 0: No fault reported 1: Fault reported Thousand's place: whether to decelerate or not when overload alarm 0: No deceleration 1: Deceleration Ten thousand's place: given mode for overload threshold 0: F11.19 set 1: F11.19*VP 2: F11.19*AI1 3: F11.19*AI2 4: F11.19*AI3	00010	×
F11.19	Overload alarm threshold	0.0~200.0%	130.0%	×
F11.20	Overload alarm activated time that exceeding threshold	0.1~60.0s	5.0s	×
F11.21	Drive overheat warning threshold	50℃~overheat Temperature	Model defined	×
F11.22	Detection level of load loss	5.0~100.0%	20.0%	×
F11.23	Detection time of load loss	0.1~60.0s	5.0s	×
F11.24	Action selection at instantaneous power failure	0: Disabled 1: Deceleration 2: Bus voltage constant control	0	×
F11.25	Decel time at instantaneous power failure	0.0~6000.0s	5.0s	△
F11.26	Rapid current limit	0: Disabled 1: Rapid current limiting mode 1	0	×
F11.27	Times of automatic trip(fault) reset	0~20	0	×
F11.28	Interval of automatic trip(fault) reset	0.1~100.0s	1.0s	×
F11.29	DO action during fault auto reset	0: Not act 1: Act	0	×
F11.30	Instantaneous power off bus voltage	60.0%~Recovery voltage	80.0%	△
F11.31	Instantaneous power off recovery voltage	Power off voltage~100.0%	85.0%	△

F11.32	Instantaneous power off voltage detection time	0.01~10.00s	0.10s	△
F11.33	Instantaneous power off Kp	0.1~100.0%	40.0%	△
F11.34	Instantaneous power off integration time Ti	0.00~10.00s (0.00: Integration invalid)	0.10s	△
Group F12: Multi-Reference and Simple PLC Function				
F12.00	Reference 0	-100.0~100.0%	0.0%	△
F12.01	Reference 1	-100.0~100.0%	0.0%	△
F12.02	Reference 2	-100.0~100.0%	0.0%	△
F12.03	Reference 3	-100.0~100.0%	0.0%	△
F12.04	Reference 4	-100.0~100.0%	0.0%	△
F12.05	Reference 5	-100.0~100.0%	0.0%	△
F12.06	Reference 6	-100.0~100.0%	0.0%	△
F12.07	Reference 7	-100.0~100.0%	0.0%	△
F12.08	Reference 8	-100.0~100.0%	0.0%	△
F12.09	Reference 9	-100.0~100.0%	0.0%	△
F12.10	Reference 10	-100.0~100.0%	0.0%	△
F12.11	Reference 11	-100.0~100.0%	0.0%	△
F12.12	Reference 12	-100.0~100.0%	0.0%	△
F12.13	Reference 13	-100.0~100.0%	0.0%	△
F12.14	Reference 14	-100.0~100.0%	0.0%	△
F12.15	Reference 15	-100.0~100.0%	0.0%	△
F12.16	Reference 0 source	0: Digital setting (F12.00)	0	×
		1: keypad potentiometer		
		2: AI1		
		3: Process PID output		
		4: X7/HI pulse input		
		5: AI2		
F12.17	Running mode of simple PLC	Unit's place: PLC running mode 0: Stop after a single cycle 1: Continue to run with the last frequency after a single cycle 2: Repeat cycles	0000	×
		Ten's place: started mode 0: Continue to run from the step of stop (or fault) 1: Run from the first step "multi-step frequency 0" 2: Run from the eighth step "multi-step frequency 8" 3: Run from the fifteenth step "multi-step frequency 15"		
		Hundreds place: power loss memory 0: Memory disabled on power loss 1: Memory enabled on power loss		
		Thousands place: unit of simple PLC running time 0: Second (s) 1: Minute (min)		
F12.18	Running time of step 0	0.0~6000.0s(h)	0.0s(h)	△

FR01 Series Smart Inverter

F12.19	Running time of step 1	0.0~6000.0s(h)	0.0s(h)	△
F12.20	Running time of step 2	0.0~6000.0s(h)	0.0s(h)	△
F12.21	Running time of step 3	0.0~6000.0s(h)	0.0s(h)	△
F12.22	Running time of step 4	0.0~6000.0s(h)	0.0s(h)	△
F12.23	Running time of step 5	0.0~6000.0s(h)	0.0s(h)	△
F12.24	Running time of step 6	0.0~6000.0s(h)	0.0s(h)	△
F12.25	Running time of step 7	0.0~6000.0s(h)	0.0s(h)	△
F12.26	Running time of step 8	0.0~6000.0s(h)	0.0s(h)	△
F12.27	Running time of step 9	0.0~6000.0s(h)	0.0s(h)	△
F12.28	Running time of step 10	0.0~6000.0s(h)	0.0s(h)	△
F12.29	Running time of step 11	0.0~6000.0s(h)	0.0s(h)	△
F12.30	Running time of step 12	0.0~6000.0s(h)	0.0s(h)	△
F12.31	Running time of step 13	0.0~6000.0s(h)	0.0s(h)	△
F12.32	Running time of step 14	0.0~6000.0s(h)	0.0s(h)	△
F12.33	Running time of step 15	0.0~6000.0s(h)	0.0s(h)	△
F12.34	Acceleration/deceleration time of simple PLC reference 0	0~3	0	△
F12.35	Acceleration/deceleration time of simple PLC reference 1	0~3	0	△
F12.36	Acceleration/deceleration time of simple PLC reference 2	0~3	0	△
F12.37	Acceleration/deceleration time of simple PLC reference 3	0~3	0	△
F12.38	Acceleration/deceleration time of simple PLC reference 4	0~3	0	△
F12.39	Acceleration/deceleration time of simple PLC reference 5	0~3	0	△
F12.40	Acceleration/deceleration time of simple PLC reference 6	0~3	0	△
F12.41	Acceleration/deceleration time of simple PLC reference 7	0~3	0	△
F12.42	Acceleration/deceleration time of simple PLC reference 8	0~3	0	△
F12.43	Acceleration/deceleration time of simple PLC reference 9	0~3	0	△
F12.44	Acceleration/deceleration time of simple PLC reference 10	0~3	0	△
F12.45	Acceleration/deceleration time of simple PLC reference 11	0~3	0	△
F12.46	Acceleration/deceleration time of simple PLC reference 12	0~3	0	△
F12.47	Acceleration/deceleration	0~3	0	△

	time of simple PLC reference 13			
F12.48	Acceleration/deceleration time of simple PLC reference 14	0~3	0	△
F12.49	Acceleration/deceleration time of simple PLC reference 15	0~3	0	△
F12.50	UP/DOWN selection of Multi-function reference	Unit's place: Action selection when power off 0:Zero clearing when power off 1:Hold when power off Ten's place: select if it can be reduced to negative 0:Disable 1:Enable	00	×
F12.51	UP/DOWN speed of Multi-reference	0.0~100.0% (0.0%Invalid)	0.0%	△
Group F13 Process PID				
F13.00	PID setting	0: F13.01 digital setting 1:keypad potentiometer 2: AI1 3: Communication 4: Multi-Reference 5: DI7/HI pulse input 6: AI2 7: AI3	0	×
F13.01	PID digital setting	0.0~100.0%	50.0%	△
F13.02	PID feedback	0: AI1 1: AI2 2: Communication 3: AI1+AI2 4: AI1-AI2 5: Max{AI1, AI2} 6: Min{AI1, AI2} 7: DI7/HI pulse input 8: AI3	0	×
F13.03	PID setting feedback range	0.0~6000.0	100.0	△
F13.04	PID action direction	0: Forward action 1: Reverse action	0	×
F13.05	Filtering time of PID setting	0.000~10.000s	0.000s	△
F13.06	Filtering time of PID feedback	0.000~10.000s	0.000s	△
F13.07	Filtering time of PID output	0.000~10.000s	0.000s	△
F13.08	Proportional gain Kp1	0.0~100.0	1.0	△
F13.09	Integration time Ti1	0.00~10.00s	0.10s	△
F13.10	Differential time Td1	0.000~10.000s	0.000s	△
F13.11	Proportional gain Kp2	0.0~100.0	1.0	△
F13.12	Integration time Ti2	0.00~10.00s	0.10s	△
F13.13	Differential time Td2	0.000~10.000s	0.000s	△
F13.14	PID parameter switch	0: No switch, determined by parameters Kp1, Ti1 and Td1 1: Auto switch on the basis of input offset	0	×

FR01 Series Smart Inverter

		2: Switched by terminal		
F13.15	PID parameter switchover deviation 1	0.0~100.0%	20.0%	×
F13.16	PID parameter switchover deviation 2	0.0~100.0%	80.0%	×
F13.17	PID offset limit	0.0~100.0%	0.0%	×
F13.18	PID integral property	Unit's place (Whether to stop integral operation when the output reaches the limit) 0: Continue integral operation 1: Stop integral operation	000	×
		Ten's place (Integral separated) 0: Invalid 1: Valid		
		Hundred's place: PID control algorithm 0: Incremental type 1: Positional type		
F13.19	PID differential limit	0.0~100.0%	0.5%	×
F13.20	PID initial value	0.0~100.0%	0.0%	×
F13.21	Holding time of PID initial value	0.0~6000.0s	0.0s	×
F13.22	PID output frequency upper limit	PID output frequency lower limit~100.0% (100.0% corresponds to maximum frequency)	100.0%	×
F13.23	PID output frequency lower limit	-100.0%~PID output frequency lower limit	0.0%	×
F13.24	Low value of PID feedback loss	0.0~100.0% 0.0:Not judging feedback loss	0.0%	×
F13.25	Detection time for low value of PID feedback loss	0.0~30.0s	1.0s	×
F13.26	PID operation selection	Unit's place: PID operation selection when stop 0:Do not operate when stop 1:Operate when stop	00000	×
		Ten's place: output is limited by output frequency 0:No limited 1:limited		
		Hundred's place: UP/DOWN digital given of PID 0:Zero clearing when power off 1:Hold when power off		
		Thousand's place: PID feedback loss detection when stop 0:Not detect when stop 1:detect when stop		
		Then thousand's place: action for PID feedback loss 0:Report fault 1:Ramp to stop		
		Unit's place: PID operation selection when stop 0:Do not operate when stop 1:Operate when stop		
F13.27	UP/DWON speed of PID	0.0~100.0% (0.0% Invalid)	0.0%	△

	digital given			
F13.28	High value of PID feedback loss	0.0~100.0% 0.0: Invalid	100.0%	×
F13.29	Detection time for high value of PID feedback loss	0.0~30.0s	1.0s	×
F13.30	PID upper limit source	0:F13.22 1:F13.22*VP 2:F13.22*AI1 3:F13.22*AI2 4:F13.22*HI 5:F13.22*AI3	0	×
F13.31	PID lower limit source	0:F13.23 1:F13.23*VP 2:F13.23*AI1 3:F13.23*AI2 4:F13.23*HI 5:F13.23*AI3	0	×
Group F14: Swing Frequency, Fixed Length , Wakeup and Count				
F14.00	Swing frequency setting mode	0: Relative to the setting frequency	0	×
		1: Relative to the maximum frequency		
F14.01	Swing frequency amplitude	0.0~100.0% (Relative to the set frequency, 0.0 swing frequency is invalid)	0.0%	△
F14.02	Jump frequency amplitude	0.0~50.0% (Relative swing amplitude)	0.0%	△
F14.03	Rising Time of Swing frequency	0.0~6000.0s	5.0s	△
F14.04	Dropping Time of Swing frequency	0.0~6000.0s	5.0s	△
F14.05	Set length	0m~65535m	1000m	×
F14.06	Number of pulses per meter	0.1~6553.5	100.0	×
F14.07	Command when the length attained	Unit's place: stop when the length reaches 0: Not stop 1: Stop	00	×
		Ten's place: length calculation method 0: pulse by pulse 1: Reference maximum frequency 2: Refer to AI1 channel 3: Refer to AI2 channel 4: Refer to AI3 channel		
F14.08	Set count value	1~65535	1000	×
F14.09	Designated count value	1~65535	1000	×
F14.10	Wakeup frequency	Dormant frequency (F14.12)~Fmax	0.00Hz	△
F14.11	Wakeup delay time	0.0~6000.0s	0.0s	△
F14.12	Dormant frequency	0.00~Wakeup frequency	0.00Hz	△
F14.13	Dormant delay time	0.0~6000.0s	0.0s	△
F14.14	Wake up mode selection	0: Frequency	0	×
		1: Pressure		
F14.15	Dormancy mode selection	0: Frequency	0	×
		1: Pressure		

F14.16	Voltage feedback source	Unit's place: pressure feedback 0: AI1 1: AI2 2: DI7/HI pulse input 3: AI3	00	×
		Ten's place: pressure dormancy mode 0:Positive direction, dormancy on big pressure and wakeup on small pressure 1:Negative direction, dormancy on small pressure and wakeup on big pressure		
F14.17	Wake up pressure	0.0%~100.0%	10.0%	△
F14.18	Dormancy pressure	0.0%~100.0%	50.0%	△
Group F15: Communication Parameters				
F15.00	Baud rate	0:4800bps	1	×
		1:9600bps		
		2:19200bps		
		3:38400bps		
		4:57600bps		
F15.01	Data format	No check, data format (1-8-N-2) for RTU	0	×
		1: Even parity check, data format (1-8-E-1) for RTU		
		2: Odd Parity check, data format (1-8-O-1) for RTU		
		3: No check, data format(1-8-N-1) for RTU		
F15.02	Local address	1~247 0:Broadcast address	1	×
F15.03	Communication timeout	0.0~60.0s	0.0s	×
F15.04	Response time delay	0~200ms	1ms	×
F15.05	Master-slave Communication Mode	0:The Drive is the slave	0	×
		1:The Drive is the master		
F15.06	The Master Communication Sending Data	0: Set frequency	0	×
		1: Current running frequency		
F15.07	Message return when communication error	0: No return	1	△
		1: Return		
F15.08	U group return value	0: Positive and negative	0	△
		1: Absolute value		
Group F16 Keys and Display of Keypad Parameters				
F16.01	Keyboard display operation	Unit's digit: Function selection of STOP/RESET key 0: stop function of STOP/RESET key is valid only in keyboard operation mode 1: Stop function of STOP/RES key is valid in any operation mode	001	×
		Ten's digit: Speed display (U00.05) 0: According to the actual speed 1: Multiply frequency by speed coefficient(F16.11)		
		Hundred's digit: Decimal places		

		0: No decimal places 1: One decimal places 2: Two decimal places 3: Three decimal places		
F16.03	LED displayed parameters setting 1 on running status	0 ~ 99(correspond U00.00 ~ U00.99)	0	△
F16.04	LED displayed parameters setting 2 on running status	0 ~ 99(correspond U00.00 ~ U00.99)	6	△
F16.05	LED displayed parameters setting 3 on running status	0 ~ 99(correspond U00.00 ~ U00.99)	3	△
F16.06	LED displayed parameters setting 4 on running status	0 ~ 99(correspond U00.00 ~ U00.99)	2	△
F16.07	LED displayed parameters setting 1 on stop status	0 ~ 99(correspond U00.00 ~ U00.99)	1	△
F16.08	LED displayed parameters setting 2 on stop status	0 ~ 99(correspond U00.00 ~ U00.99)	6	△
F16.09	LED displayed parameters setting 3 on stop status	0 ~ 99(correspond U00.00 ~ U00.99)	15	△
F16.10	LED displayed parameters setting 4 on stop status	0 ~ 99(correspond U00.00 ~ U00.99)	16	△
F16.11	Speed display coefficient	0.00~100.00	1.00	△
F16.12	Power display coefficient	0.0~300.0%	100.0%	△
F16.13	The enable difference range of U00.00 and U00.01	0.00Hz~5.00Hz	0.10Hz	△
F22Group:Virtual IO				
F22.00	Function selection of virtual VDI1 terminal	The same as function code F04.00	0	×
F22.01	Function selection of virtual VDI2 terminal	The same as function code F04.00	0	×
F22.02	Function selection of virtual VDI3 terminal	The same as function code F04.00	0	×
F22.03	Function selection of virtual VDI4 terminal	The same as function code F04.00	0	×
F22.04	Function selection of virtual VDI5 terminal	The same as function code F04.00	0	×
F22.05	Valid status setting mode of virtual VDI terminals	VDI5、VDI4、VDI3、VDI2、VDI1 0:Validity of VDI depends on virtual VDOx's status 1:Validity of VDI set by function code F22.06	00000	×
F22.06	Settings of virtual VDI terminal status	VDI5、VDI4、VDI3、VDI2、VDI1 0: Invalid 1: Valid	00000	△
F22.07	Function selection of virtual VDO1 terminals output	0 : Internal short circuited to physics Dlx Other: The same as function code F05.00	0	△
F22.08	Function selection of virtual VDO2 terminals output	0 : Internal short circuited to physics Dlx Other: The same as function code F05.00	0	△
F22.09	Function selection of virtual VDO3 terminals output	0 : Internal short circuited to physics Dlx Other: The same as function code F05.00	0	△

FR01 Series Smart Inverter

F22.10	Function selection of virtual VDO4 terminals output	0 : Internal short circuited to physics DIx Other: The same as function code F05.00	0	△
F22.11	Function selection of virtual VDO5 terminals output	0 : Internal short circuited to physics DIx Other: The same as function code F05.00	0	△
F22.12	Virtual VDO1 output delay time	0.0s~6000.0s	0.0s	△
F22.13	Virtual VDO2 output delay time	0.0s~6000.0s	0.0s	△
F22.14	Virtual VDO3 output delay time	0.0s~6000.0s	0.0s	△
F22.15	Virtual VDO4 output delay time	0.0s~6000.0s	0.0s	△
F22.16	Virtual VDO5 output delay time	0.0s~6000.0s	0.0s	△
F22.17	VDO output terminal positive and negative logic	VDO5、VDO4、VDO3、VDO2、VDO1	00000	△
		0: Positive logic		
		1: Negative logic		
Group U00 Status Monitoring				
U00.00	Running frequency	0.00~Fup	0.00Hz	⊙
U00.01	Set frequency	0.00~Fmax	0.00Hz	⊙
U00.02	Output voltage	0~660V	0.0V	⊙
U00.03	Output current	0.0~3000.0A	0.0A	⊙
U00.04	Output power	0.0~3000.0kW	0.0kW	⊙
U00.05	Estimated Motor Speed	0~60000rpm	0rpm	⊙
U00.06	Bus voltage	0~1200V	0V	⊙
U00.07	Synchronous Frequency	0.00~Fup	0.00Hz	⊙
U00.08	PLC step	0~15	0	⊙
U00.09	Program Operation Time	0.0~6000.0s(h)	0.0s(h)	⊙
U00.10	PID set	0~60000	0	⊙
U00.11	PID feedback	0~60000	0	⊙
U00.12	Status of DI1 ~ DI5 digital input terminal	DI5 DI4 DI3 DI2 DI1	00000	⊙
U00.13	Status of DI6 ~ DI7 digital input terminal	DI7 DI6	00	⊙
U00.14	Status of digital output terminal	R2 R1 Y2 Y1	0000	⊙
U00.15	AI1 input	0.0~100.0%	0.0%	⊙
U00.16	AI2 input	0.0~100.0%	0.0%	⊙
U00.17	AI3 input	0.0~100.0%	0.0%	⊙
U00.18	Keypad potentiometer input	0.0~100.0%	0.0%	⊙
U00.19	HI input	0.00~100.00kHz	0.00kHz	⊙
U00.20	AO1 output	0.0~100.0%	0.0%	⊙
U00.21	AO2 output	0.0~100.0%	0.0%	⊙
U00.22	HO output	0.00~100.00kHz	0.00kHz	⊙
U00.23	Temperature of Drive	-40.0℃~120.0℃	0.0℃	⊙
U00.24	Accumulative power-on time	0~65535min	0min	⊙

U00.25	Accumulative running time	0~6553.5min	0.0min	⊙
U00.26	Cumulative power-on time	0~65535h	0h	⊙
U00.27	Cumulative running time	0~65535h	0h	⊙
U00.28	Count value	0~65535	0	⊙
U00.29	Length value	0~65535m	0m	⊙
U00.30	Linear speed	0~65535m/min	0m/Min	⊙
U00.31	Output torque	0.0~300.0%	0.0%	⊙
U00.32	PTC motor temperature detection	-40℃~200℃	0℃	⊙
U00.33	Speed that detected by encoder	0~60000rpm	0rpm	⊙
U00.34	Monitoring of encoder line number	0~65535	0	⊙
U00.35	Power consumption	0~65535kWh	0kWh	⊙
Group U01 Fault Record				
U01.00	Code of the latest fault	Err00:无故障	Err00	⊙
		Err01:Accel overcurrent		
		Err02:Decel overcurrent		
		Err03:Constant-speed overcurrent		
		Err04:Accel overvoltage		
		Err05:Decel overvoltage		
		Err06:Constant-speed overvoltage		
		Err07:Bus undervoltage		
		Err08:Short circuit		
		Err09:Power input phase loss		
		Err10:Power output phase loss		
		Err11:Motor overload		
		Err12:Drive overload		
		Err13:External equipment fault		
		Err14:Module overheat		
		Err15:EEPROM read/write fault		
		Err16:Motor auto-tuning cancelled		
		Err17:Motor auto-tuning fault		
		Err18:Communication overtime error		
		Err19:PID feedback loss		
		Err20:Continuous running time reached		
		Err21:Parameter upload fault		
		Err22:Parameter download fault		
		Err23:Braking unit fault		
		Err24:Module temperature detection disconnection		
		Err25:Load becoming 0		
		Err26:With-wave current limit fault		
		Err27:Drive soft-start relay is off		
		Err28:Software version compatibility fault		
		Err29:Instantaneous overcurrent		
		Err30:Instantaneous overvoltage		
		Err36:PG card is disconnection (close loop)		
		Err37:Over Speed (close loop)		

FR01 Series Smart Inverter

		Err38:Excessive speed deviation (close loop)		
		Err39:Motor temperature too high		
		Err40:The setting running time ends		
		Err41:Overload warning		
U01.01	Running frequency when the latest fault occurred	0.00~Fup	0.00Hz	⊖
U01.02	Output current when the latest fault occurred	0.0~3000.0A	0.0A	⊖
U01.03	Bus voltage when the latest fault occurred	0~1200V	0V	⊖
U01.04	Cumulative running time when the latest fault occurred	0~65535h	0h	⊖
U01.05	Code of previous fault	Same as U01.00	Err00	⊖
U01.06	Running frequency when previous fault occurred	0.00~Fup	0.00Hz	⊖
U01.07	Output current when previous fault occurred	0.0~3000.0A	0.0A	⊖
U01.08	Bus voltage when previous fault occurred	0~1200V	0V	⊖
U01.09	Cumulative running time when previous fault occurred	0~65535h	0h	⊖
U01.10	Before-previous fault code	Same as U01.00	Err00	⊖
U01.11	Running frequency when before-previous fault occurred	0.00~Fup	0.00Hz	⊖
U01.12	Output current when before-previous fault occurred	0.0~3000.0A	0.0A	⊖
U01.13	Bus voltage when before-previous fault occurred	0~1200V	0V	⊖
U01.14	Cumulative running time when before-previous fault occurred	0~65535h	0h	⊖
U01.15	Previous 3 categories of faults	Same as U01.00	Err00	⊖
U01.16	Previous 4 categories of faults	Same as U01.00	Err00	⊖
U01.17	Previous 5 categories of faults	Same as U01.00	Err00	⊖
U01.18	Previous 6 categories of faults	Same as U01.00	Err00	⊖
U01.19	Previous 7 categories of faults	Same as U01.00	Err00	⊖
U01.20	Previous 8 categories of faults	Same as U01.00	Err00	⊖
U01.21	Previous 9 categories of faults	Same as U01.00	Err00	⊖
U01.22	Previous 10 categories of faults	Same as U01.00	Err00	⊖

U01.23	Previous 11 categories of faults	Same as U01.00	Err00	⊖
U01.24	Previous 12 categories of faults	Same as U01.00	Err00	⊖
U01.25	Previous 13 categories of faults	Same as U01.00	Err00	⊖

Chapter 6 Maintenance and Troubleshooting

FR01 inverter provides a number of warning information and protection, when a fault occurs, the protective function is activated, the inverter will stop output, inverter fault relay contact, and in the inverter displays the fault code on the display panel. Before seeking service user can press the self-examination tips in this section, analyze problems, and identify solutions. If the problem still cannot be excluded, seek services, or contact the dealer you purchase the drive with my company.

Display	Fault Name	Possible Causes	Solutions
Err01	Accel overcurrent	1: The output circuit is grounded or short circuited. 2: The acceleration time is too short. 3: Manual torque boost or V/F curve is not appropriate. 4: The voltage is too low. 5: The startup operation is performed on the rotating motor. 6: A sudden load is added during acceleration. 7: The AC drive model is of too small power class.	1: Eliminate external faults. 2: Increase the acceleration time. 3: Adjust the manual torque boost or V/F curve. 4: Adjust the voltage to normal range. 5: Select rotational speed tracking restart or start the motor after it stops. 6: Remove the added load. 7: Select an AC drive of higher power class
Err02	Decel overcurrent	1: The output circuit is grounded or short circuited. 2: The deceleration time is too short. 3: The voltage is too low. 4: A sudden load is added during deceleration. 5: The braking unit and braking resistor are not installed.	1: Eliminate external faults. 2: Increase the deceleration time. 3: Adjust the voltage to normal range. 4: Remove the added load. 5: Install the braking unit and braking resistor.
Err03	Constant-speed overcurrent	1: The output circuit is grounded or short circuited. 2: The voltage is too low. 3: A sudden load is added during operation. 4: The AC drive model is of too small power class.	1: Eliminate external faults 2: Adjust the voltage to normal range. 3: Remove the added load 4: Select an AC drive of higher power class.
Err04	Accel overvoltage	1: The input voltage is too high. 2: An external force drives the motor during acceleration. 3: The acceleration time is too short. 4: The braking unit and braking resistor are not installed.	1: Adjust the voltage to normal range. 2: Cancel the external force or install a braking resistor. 3: Increase the acceleration time. 4: Install the braking unit and braking resistor.
Err05	Decel overvoltage	1: The input voltage is too high. 2: An external force drives the motor during deceleration. 3: The deceleration time is too short.	1: Adjust the voltage to normal range. 2: Cancel the external force or install the braking resistor.

Display	Fault Name	Possible Causes	Solutions
		4: The braking unit and braking resistor are not installed.	3: Increase the deceleration time. 4: Install the braking unit and braking resistor.
Err06	Constant-speed overvoltage	1: The input voltage is too high 2: An external force drives the motor during deceleration.	1: Adjust the voltage to normal range. 2: Cancel the external force or install the braking resistor.
Err07	Bus under voltage	1: Instantaneous power failure occurs on the input power supply. 2: The AC drive's input voltage is not within the allowable range. 3: The bus voltage is abnormal. 4: The rectifier bridge and buffer resistor are faulty. 5: The drive board is faulty. 6: The main control board is faulty.	1: Reset the fault. 2: Adjust the voltage to normal range. 3: Contact the agent or Frecon.
Err08	Short circuit	1: The output circuit is grounded or short circuited. 2: The connecting cable of the motor is too long. 3: The module overheats. 4: The internal connections become loose. 5: The main control board is faulty 6: The drive board is faulty. 7: The inverter module is faulty.	1: Eliminate external faults. 2: Install a reactor or an output filter. 3: Check the air filter and the cooling fan. 4: Connect all cables properly. 5: Contact the agent or Frecon.
Err09	Power input phase loss	1: The three-phase power input is abnormal. 2: The drive board is faulty. 3: The lightning board is faulty. 4: The main control board is faulty.	1: Eliminate external faults. 2: Contact the agent or FRECON.
Err10	Power output phase loss	1: The cable connecting the AC drive and the motor is faulty. 2: The AC drive's three-phase outputs are unbalanced when the motor is running. 3: The drive board is faulty. 4: The module is faulty.	1: Eliminate external faults. 2: Check whether the motor Three-phase winding is normal. 3: Contact the agent or Frecon.
Err11	Motor overload	1: F11-17 is set improperly. 2: The load is too heavy or locked-rotor occurs on the motor. 3: The AC drive model is of too small power class.	1: Set F11-17 correctly. 2: Reduce the load and check the motor and the mechanical condition. 3: Select an AC drive of higher power class.
Err12	Inverter overload	1: The load is too heavy or locked-rotor occurs on the motor. 2: The AC drive model is of too small power class.	1: Reduce the load and check the motor and mechanical condition. 2: Select an AC drive of higher power class.
Err13	External equipment fault	1: External fault signal is input via DI.	Reset the operation.
Err14	Module overheat	1: The ambient temperature is too high. 2: The air filter is blocked.	1: Lower the ambient temperature. 2: Clean the air filter.

Display	Fault Name	Possible Causes	Solutions
		3: The fan is damaged. 4: The thermally sensitive resistor of the module is damaged. 5: The inverter module is damaged.	3: Replace the damaged fan. 4: Replace the damaged thermally sensitive resistor. 5: Replace the inverter module.
Err15	EEPROM read/write fault	The EEPROM chip is damaged.	Replace the main control board.
Err16	Motor auto-tuning cancelled	Since the identification process, press STOP / RST key	Press STOP / RST key to reset
Err17	Motor auto-tuning fault	1: the motor and the inverter output terminals are not connected 2: The motor does not disengage the load 3: The electrical fault	1: check the connection between the inverter and motor 2: The motor is disengaged load 3: Check the motor
Err18	Communication overtime error	1: The PC is not working properly 2: The communication line is not normal 3: F15 set communication parameters set incorrectly	1: Check the PC Connection 2: Check the communication cable 3: The communication parameters are set correctly
Err19	PID feedback loss	PID feedback set value is less than F13.24	Check the PID feedback signal or set to an appropriate value F13.24
Err20	Continuous running time reached	Set the running time to reach this function	reference F05.14 Description
Err21	Parameter upload fault	1: Is not installed or is not plugged parameter copy card 2: Parameter copy card anomalies 3: The control board abnormalities	1: a copy of the card is properly installed parameters 2: for technical support 3: for technical support
Err22	Parameter download fault	1: Is not installed or is not plugged parameter copy card 2: Parameter copy card anomalies 3: The control board abnormalities	1: A copy of the card is properly installed parameters 2: For technical support 3: For technical support
Err23	Braking unit fault	1: The brake line failure or damage the brake pipe 2: An external braking resistor is too small	1: Check the brake unit, replace the brake pipe 2: Increasing the braking resistor
Err24	Module temperature detection disconnection	The temperature sensor failure or cable break	For technical support
Err25	Load becoming 0	The AC drive running current is lower than F11.22	Check that the load is disconnected or the setting F11-22 and F11-23 is correct.
Err26	With-wave current limit fault	1: The load is too heavy or locked rotor occurs on the motor. 2: The AC drive model is of too small power class.	1: Reduce the load and check the motor and mechanical condition. 2: Select an AC drive of higher power class.

Display	Fault Name	Possible Causes	Solutions
Err27	Inverter soft-start relay is off	1: The grid voltage is too low 2: Rectifier module failure	1: Check the grid voltage 2: Demand for technical support
Err28	Software version compatibility fault	1: The upper and lower transmission module parameters in the parameter version of the control panel version mismatch.	re-upload module parameters to pass down
Err40	The setting running time ends	Running time more than F00.25	1.Contact the dealer
Err41	Overload warning	Overload	1、 check F11.19 2: Select an AC drive of higher power class.
Err42	Pulse feedback disconnection	No pulse input	1、 check the terminal that is of pulse input or the Pulse Generator
Err48	The synchronous machine failed to start	The parameter Settings of group F10 are incorrect	Check the parameter Settings of group F10 of the synchronous motor

Appendix A: Modbus Communication Protocol

1. Application Scope

1. Applicable series: FR series inverter.
 2. Applicable network: Support Modbus protocol, RTU format, with single-master/multi-slave Communication network of RS485 bus.
- The typical RTU message frame format:

Start Bit	Device Address	Function Code	Data	CRC	Stop Bit
T1-T2-T3-T4	8Bit	8Bit	n*8Bit	16Bit	T1-T2-T3-T4

2. Physical Interface

RS485 is asynchronous half-duplex Communication mode. LSB has transmission priority. Default data format of RS485 terminal: 1-8-N-1, bits rate: 9600bps. Data format 1-8-N-1, 1-8-O-1, 1-8-E-1, optional bits rates 4800bps, 9600bps, 19200bps, 38400bps, 57600bps and 115200bps can be selected. Shielded twisted-pair cable is recommended Communication cable to lower external interference.

When the number of slaves is large, the 485 signals of all slaves are connected together with reference, and the branch distance of each slave is less than 3m. to reduce the impact of external interference on communications.

3. Protocol Format

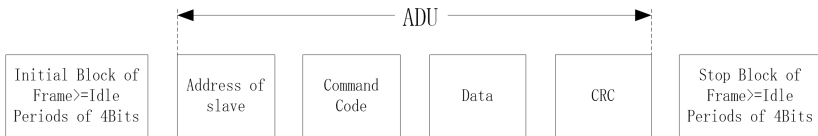

The parity in ADU (Application Data Unit) is obtained via the CRC16 parity of the 1st three Parts of ADU and switch the low bytes and high bytes. Low bytes of CRC parity go first, and high bytes of it follow in the protocol format.

4. Description of Protocol Format

4.1 Address Code

Address of slave inverter. The setting range: 1~247, 0 is broadcast address.

4.2 Command Code

Command Code	Function
03H	Read parameters and status byte of inverter
06H	Write single function code or control parameter of inverter
08H	Circuit diagnosis and setting

4.3 Allocation of Register Addresses

name	Description

Function Code (F00.00~ U01.99)	<p>High byte function code group number, F00 ~ F31, U00, U01, respectively, corresponding to the high byte address is 00H~1FH, 30H, 31H.</p> <p>Low byte of the group function code number, from 0 to 99 corresponding to the low byte address is 00H~63H.</p> <p>For example: Modify F01.02 function code value, no power-down when storing the corresponding register address (referred to as RAM address) to 0102H.</p> <p>EEPROM is frequently modified, will reduce the life of the EEPROM. If you modify the value of the function code-down storage needs, you can make this function code is the highest position a high address. Note that this address is only to write, not read.</p> <p>For example: Modify F01.02 function code value, and the corresponding need to power down when storing the register address (referred to as EEPROM address) to 8102H.</p>
--------------------------------------	--

Function code group	RAM address high byte	EEPROM address high byte
F00	0x00	0x80
F01	0x01	0x81
F02	0x02	0x82
F03	0x03	0x83
F04	0x04	0x84
F05	0x05	0x85
F06	0x06	0x86
F07	0x07	0x87
F08	0x08	0x88
F09	0x09	0x89
F10	0x0A	0x8A
F11	0x0B	0x8B
F12	0x0C	0x8C
F13	0x0D	0x8D
F14	0x0E	0x8E
F15	0x0F	0x8F
F16	0x10	0x90
F17	0x11	0x91
F22	0x16	0x96
U00 (Read Only)	0x30	--
U01 (Read Only)	0x31	--

4.4 Address and control command functions: (write only)

Command word address	Command Function
2000H	0001: Forward run 0002: Reverse Run 0003: Inching Forward 0004: Reverse Jog 0005: Slowdown stop 0006: Freewheel 0007: Fault reset
2001H	Communication setting frequency (0~Fmax (Unit: 0.01Hz))
2002H	PID given range (0 to 1000, 1000 corresponds to 100.0%)
2003H	PID feedback range (0~1000, 1000 corresponds to 100.0%)
2004H	Torque set point (-3000~3000, 1000 corresponds to 100.0% motor rated current)

4.5 The status and function of the read address Description: (read only)

Status word address	functional status word
2100H	0000H: parameter setting 0001H: slave run

	0002H: JOG operation 0003H: learning run 0004H: Slave parking 0005H: JOG parking 0006H: Fault Status
2101H	Bit0: 0 are given effective 1 Given negative effective Bit1: 0 frequency output Forward 1 frequency output inversion Bit2~3: 00 Keyboard start-stop 01 terminal start-stop 10 start-stop communication 11 Reserved Bit4: 0 Factory password is invalid 1 factory password is valid Bit5: 0 user password is invalid 1 valid user password Bit6~7: 00 basic function code group 01 user-defined function code group 10 different functions with the factory default code group 11 Others
2102H	The current fault type of the drive
2103H	The current warning type of the drive

5. Explanation of Command

Command code 0x03: Read parameter and status of inverter.

ADU Item	Byte No.	Range
Master requests:		
Address of slave	1	0~127
Command Code	1	0x03
Register start address	2	0x0000~0xFFFF
The number of register	2	0x0000~0x0008
CRC parity(Low bytes go first)	2	
Slave responds :		
Address of slave	1	The local address
Command Code	1	0x03
Register start address	1	2 number of registers
The number of register	2 number of registers	
CRC parity	2	

Remarks: Read maximum 8 function codes consecutively.

Command code 0x06: Write single function code or control parameter of inverter.

ADU Item	Byte No.	Range
Master requests:		
Address of slave	1	0~127
Command Code	1	0x06
Register start address	2	0x0000~0xFFFF
The number of register	2	0x0000~0xFFFF
CRC parity	2	
Slave responds :		
Address of slave	1	The local address
Command Code	1	0x06

Register start address	2	0x0000~0xFFFF
The number of register	2	0x0000~0xFFFF
CRC parity	2	

Command code 0x08: Circuit Diagnosis and Setting

ADU Item	Byte No.	Range
Master requests:		
Address of slave	1	0~127
Command Code	1	0x08
Register start address	2	0x0000~0xFFFF
The number of register	2	
CRC parity	2	
Slave responds :		
Address of slave	1	The local address
Command Code	1	0x08
Register start address	2	0x0000~0xFFFF
The number of register	2	
CRC parity	2	

Remarks: Command code 0x08 is only for circuit check.

6. CRC Parity

Sending equipment calculates CRC parity value first, and then attaches it to the sending message. Upon receipt of the message, receiving equipment will calculate CRC parity value again, and compare the operation result with received CRC parity value. If the two values are different, it indicates that there is error during transmission.

Calculation process of CRC parity:

1. Define a CRC parity register, and initialize it as FFFFH.
2. Conduct XOR calculation between the first byte of sending message and the value of CRC parity register, and then upload the result to CRC parity register. Start from address code, the start bit and stop bit will not be calculated.
3. Collect and check LSB (the least significant bit of CRC parity register).
4. If LSB is 1, shift each bit of CRC parity register rightwards by 1 bit, the highest bit filled with 0. Conduct XOR calculation between the value of CRC register and A001H, and then upload the result to CRC parity register.
5. If LSB is 0, shift each bit of CRC parity register rightwards by 1 bit, the highest bit filled with 0.
6. Repeat steps 3, 4 and 5 until completing 8 rounds of shifting.
7. Repeat steps 2, 3, 4, 5 and 6, and process the next byte of sending message. Repeat above process continuously until each byte of sending message is processed.
8. CRC parity date will be saved in CRC parity register after calculation.
9. LUT (Look-up table) method is to obtain CRC parity in the system with limited time resources. Simple CRC functions as shown in following (C language Programming):

```

unsigned int CRC_Cal_Value (unsigned char Data, unsigned char Length)
{
    unsigned int crc_value = 0xFFFF;
    int i = 0;
    while (Length--)
    {
        crc_value ^= Data++;
        for (i=0; i<8; i++)
        {
            if (crc_value & 0x0001)
            {
                crc_value = (crc_value>>1) ^ 0xa001;
            }
            else
            {
                crc_value = crc_value>>1;
            }
        }
    }
    return (crc_value);
}

```

7. Error Message Response

Inverter will send an error message report when the master sends error data or inverter receives the error data due to the external interference.

When Communication error occurs, slave combines the highest bit 1 of command code and error code as the response to the master.

Responding data frame format when errors happened in Communication:

ADU Item	Byte No.	Range
Error response:		
Address of slave	1	0~127
Error command code	1	The highest bit 1 of command code
Error code	1	0x01~0x13
CRC parity(Low bytes go first)	2	

Responding command code at normal Communication and error Communication

Responding Command Code at Normal Communication	Responding Command Code at Error Communication
03H	83H
06H	86H
08H	88H

Description of Error Code:

error	Description	error	Description
01H	Exceptional command code	03H	Illegal Data
02H	Exceptional data address	04H	Operation failed

For example, for U00.00 write data 50.00HZ frequency. The host sends the data frame (hex):

01H	06H	30H	00H	13H	88H	8BH	9CH
-----	-----	-----	-----	-----	-----	-----	-----

Because F00.00 is read only, inverter responds error message. Inverter responds data frame in hexadecimal format:

01H	86H	02H	C3H	A1H
-----	-----	-----	-----	-----

Command code is 86H in error message, the highest bit 1 of 06H. If error code detail is 11H, it means the parameter is read only.

After responding to the error data receipt, master can revise the responding program via resending data frame or based on the error message responded by the inverter.

8. Illustration

1, No. 01 reads the output frequency value (U00.00), returned 5000, that 50.00Hz.

To send data:

01 03 30 00 00 01 8B 0A

The received data is:

01 03 02 13 88 B5 12

2, No. 01 Drive communication given frequency 30.00Hz, send the data content of 3000.

To send data:

01 06 20 01 0B B8 D4 88

The received data is:

01 06 20 01 0B B8 D4 88

3, communications sent on the 1st drive forward run command, write to the address 2000H 01

To send data:

01 06 20 00 00 01 43 CA

The received data is:

01 06 20 00 00 01 43 CA

4, No. 01 communications sent inverter deceleration stop command, the address to write to 2000H 05

To send data:

01 06 20 00 00 05 42 09

The received data is:

01 06 20 00 00 05 42 09

Appendix B: Braking Resistors

When the inverter decelerates with a large inertia load or needs to decelerate sharply, the motor will be in the state of power generation, and the load energy will be transmitted to the DC link of the inverter through the inverter bridge, causing the voltage of the inverter bus to rise, when it exceeds a certain value, the inverter will report an overvoltage fault, and even lead to the overvoltage damage of the power module inside the inverter, in order to prevent the occurrence of this phenomenon, the brake component must be configured.

The following is the recommended braking resistor power and resistance value. Depending on the load, the user can change the value appropriately, but it must be within the recommended range.

◆FR01 braking resistor selection:

Inverter Model No.	Brake unit		125% braking torque (10% ED, max 10 sec)		Minimum enabled brake resistance
			Resistance(Ω)	Quantity	
FR01-2S-0.2B-H	Standard built-in		100W 360 Ω	1	360 Ω
FR01-2S-0.4B-H			100W 360 Ω	1	360 Ω
FR01-2S-0.7B-H			200W 180 Ω	1	180 Ω
FR01-2S-1.1B-H			200W 180 Ω	1	180 Ω
FR01-2S-1.5B-H			200W 180 Ω	1	180 Ω
FR01-2S-2.2B-H			400W 90 Ω	1	90 Ω
FR01-2S-4.0B-H			400W 75 Ω	1	60 Ω
FR01-4T-0.7B-H			200W 600 Ω	1	200 Ω
FR01-4T-1.5B-H			300W 360 Ω	1	200 Ω
FR01-4T-2.2B-H			300W 180 Ω	1	100 Ω
FR01-4T-4.0B-H			400W 150 Ω	1	100 Ω
FR01-4T-5.5B-H			600W 100 Ω	1	80 Ω
FR01-4T-7.5B-H			800W 75 Ω	1	60 Ω

Note: The conductor should be a voltage resistant to AC450V or above, and a temperature resistant cable of 105 °C.