

Preface

Thank you for choosing FRECON developed and produced FR500A&FR510A series vector control inverter.

FR500A&FR510A series vector control inverter is mainly positioned as a high-end market for OEM customers and the specific requirements of fan and pump load applications. Its flexible design, both embedded SVC and VF control in one, can be widely used for speed control accuracy, torque response speed, low-frequency output characteristics and other situations with higher requirements.

This user manual supplies a detailed description of FR500A &FR510A series vector control inverter includes product characterization, structural features, parameter setting, operation and commissioning, inspection maintenance and other contents. Be sure to carefully read through the safety precautions before use, and use this product on the premise that personnel and equipment safety is ensured.

IMPORTANT NOTES

- ◆ To illustrate the details of the products, pictures in this manual based on products with outer casing or safety cover being removed. When using this product, please be sure to well install outer casing or covering by the rules, and operating in accordance with the manual contents.
- ◆ The illustrations this manual for illustration only and may vary with different products you have ordered.
- ◆ The company is committed to continuous improvement of products, product features will continue to upgrade, the information provided is subject to change without notice.
- ◆ If you are using have questions, please contact our regional agents or our customer service center. Customer Service Tel 0755 -33067999.
- ◆ The company's other products please visit our website. <http://www.frecon.com.cn>



PREFACE	- 1 -
CONTENTS	- 2 -
CHAPTER 1 PRODUCT INFORMATION	- 3 -
1.1 NAMEPLATE INFORMATION	- 3 -
1.2 INFORMATION OF PRODUCT MODEL	- 4 -
1.3 TECHNICAL FEATURES	- 5 -
1.4 CONFIGURATION, MOUNTING DIMENSIONS AND WEIGHT	- 7 -
1.5 EXTERNAL DIMENSIONS OF KEYPAD	- 12 -
CHAPTER 2 WIRING AND TERMINALS	- 14 -
2.1 WIRING WAY	- 14 -
2.2 TERMINAL CONFIGURATION	- 15 -
CHAPTER 3 OPERATION AND DISPLAY	- 20 -
3.1 INTRODUCTION OF KEYPAD	- 20 -
3.2 VIEWING AND MODIFYING FUNCTION CODES	- 22 -
3.3 VIEWING STATUS PARAMETERS	- 22 -
3.4 MOTOR AUTO-TUNING	- 23 -
3.5 PASSWORD SETTING	- 23 -
3.6 KEYPAD LOCK	- 23 -
3.7 SHORTCUT MENUS FUNCTION CODE DESCRIPTION	- 23 -
CHAPTER 4 LIST OF PARAMETER	- 24 -
4.1 FIVE LED (DIGITAL) DISPLAY INDICATORS	- 25 -
4.2 STANDARD FUNCTION PARAMETERS	- 25 -
CHAPTER 5 MAINTENANCE AND TROUBLESHOOTING	- 70 -
APPENDIX A: MODBUS COMMUNICATION PROTOCOL	- 75 -
APPENDIX B: BRAKING RESISTOR	- 81 -
APPENDIX C: PG CARD	- 82 -
C.1 ABZ ENCODER PG CARD	- 83 -
C.2 ROTARY TRANSFORMER PG CARD	- 86 -
C.3 UVW ENCODER PG CARD	- 87 -
C.4 ECN1313 PG CARD	- 89 -
C.5 SIN-COS ENCODER PG CARD	- 90 -

Chapter 1 Product Information

1.1 Nameplate information

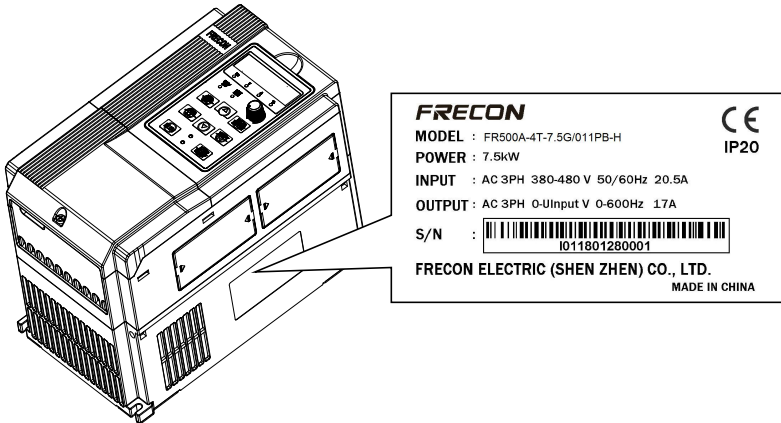

Fig.1-1 Nameplate information

Model Explanation

Model show on product nameplate contains information below.

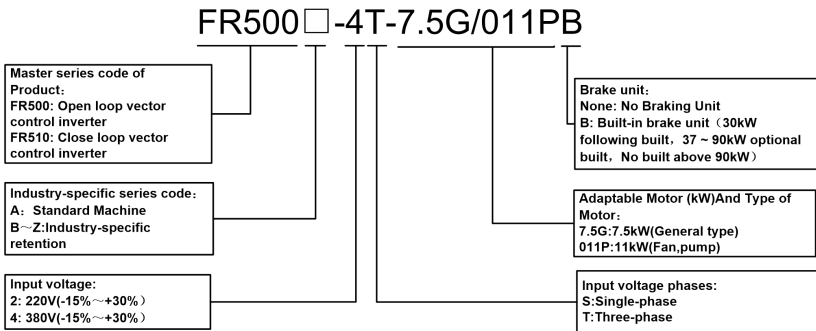

Fig.1-2 Model Explanation

1.2 Information of Product Model

Table 1-1 FR500A Product model and technical data

Model No.	Power capacity KVA	Rated Input current A	Rated output current A	Applicable motor	
				kW	HP
3-Phase:380V, 50/60Hz Range:-15%~+30%					
FR500A-4T-0.7G/1.5PB	1.5	3.4	2.5	0.75	1
FR500A-4T-1.5G/2.2PB	3	5.0	4.2	1.5	2
FR500A-4T-2.2G/4.0PB	4	5.8	5.5	2.2	3
FR500A-4T-4.0G/5.5PB	6	11	9.5	3.7, 4	5
FR500A-4T-5.5G/7.5PB	8.9	14.6	13	5.5	7.5
FR500A-4T-7.5G/011PB	11	20.5	17	7.5	10
FR500A-4T-011G/015PB	17	26	25	11	15
FR500A-4T-015G/018PB	21	35	32	15	20
FR500A-4T-018G/022PB	24	38.5	37	18.5	25
FR500A-4T-022G/030PB	30	46.5	45	22	30
FR500A-4T-030G/037PB	40	62	60	30	40
FR500A-4T-037G/045P	57	76	75	37	50
FR500A-4T-037G/045PB					
FR500A-4T-045G/055P	69	92	91	45	60
FR500A-4T-045G/055PB					
FR500A-4T-055G/075P	85	113	112	55	70
FR500A-4T-055G/075PB					
FR500A-4T-075G/090P	114	157	150	75	100
FR500A-4T-075G/090PB					
FR500A-4T-090G/110P	134	186	176	90	125
FR500A-4T-090G/110PB					
FR500A-4T-110G/132P	160	220	210	110	150
FR500A-4T-132G/160P	192	260	253	132	175
FR500A-4T-160G/185P	231	310	304	160	210
FR500A-4T-185G/200P	240	355	350	185	250
FR500A-4T-200G/220P	250	382	377	200	260
FR500A-4T-220G/250P	280	430	426	220	300
FR500A-4T-250G/280P	355	475	470	250	330
FR500A-4T-280G/315P	396	535	520	280	370
FR500A-4T-315G/355P	445	610	600	315	420
FR500A-4T-355G/400P	500	665	650	355	470
FR500A-4T-400G/450P	565	785	725	400	530
FR500A-4T-450G/500P	623	865	800	450	600
FR500A-4T-500G/560P	670	890	860	500	660
FR500A-4T-560G/630P	770	1025	990	560	750

*Note: The model of FR510A series inverter only needs to replace FR500A in the above table with FR510A

1.3 Technical Features

Table 1-2 Technical features

Project		Specifications
Power input	Rated input voltage (V)	3-phase 380 V (-15%~+30%)
	Rated input current (A)	See table 1-1
	Rated input frequency (Hz)	50Hz/60Hz, tolerance±5%
Power output	Applicable motor(kW)	See table 1-1
	Rated output current (A)	See table 1-1
	The maximum output voltage (V)	0~rated input voltage, error<±3%
	The maximum output frequency (Hz)	0.00~600.00 Hz,unit0.01Hz
Control characteristics	V/F patterns	V/f control Sensor-less vector control 1 Sensor-less vector control 2 Close loop vector control with PG card(Only FR510A)
	Speed range	1:50 (V/f control) 1:100 (sensor-less vector control 1) 1:200 (sensor-less vector control 2) 1:1000 (VC with PG card) (Only FR510A)
	Speed accuracy	±0.5% (V/F control) ±0.2% (sensor-less vector control 1 & 2)
	Speed fluctuation	±0.3% (sensor-less vector control 1 & 2)
	Torque response	< 10ms (sensor-less vector control 1 & 2)
	Starting torque	0.5Hz: 180% (V/f control, sensor-less vector control 1) 0.25Hz: 180% (sensor-less vector control 2)
Basic functions	Carrier frequency	0.7kHz~16kHz
	Overload capability	G Model:150% Rated Current 60s,180% Rated Current 10s,200% Rated Current 1s. P Model:120% Rated Current 60s,145% Rated Current 10s,160% Rated Current 1s.
	Torque boost	Automatic torque boost; Manual torque boost 0.1%~30.0%
	V/F Curve	Three ways: straight; multi-point type; N Th-type V / F curve (1.2 Th -type, 1.4 Th -type, 1.6 Th -type, 1.8 Th -type, 2 Th -type)
	Acceleration and deceleration Curve	Line or curve acceleration and deceleration mode. Four kinds of acceleration and deceleration time, Ramp Time Range :0.0~6000.0s
	DC brake	DC brake start frequency: 0.00~600.00Hz DC brake time:0.0s~10.0s DC brake current:0.0%~150.0%
Basic functions	Jog brake	Jog frequency range:0.00Hz~50.00Hz. Jog deceleration time: 0.0s~6000.0s.
	Simple PLC, Multi-speed	Through the built-in PLC or control terminal to achieve up to 16 speed running
	Built-in PID	Facilitate the realization of process control loop control system

FR500A&FR510A Series Vector Control Inverter

	Automatic voltage adjustment (AVR)	When the grid voltage changes, can automatically maintain a constant output voltage
	Fast current limit function	Minimize over current fault protection inverter running
	Over voltage Over current	System automatically limits of current and voltage during operation to prevent frequent
Run	Command source	Given the control panel, control terminal, serial communication port given.
	Frequency given	7 kinds of frequency sources: digital setting, keyboard potentiometer setting, analog Voltage, given analog current reference pulse is given, the serial port is given, multi-speed given, PLC is given, the process PI D reference. There are several ways to switch
	Input terminal	7 Switch input terminals, one way to make high-speed pulse input. 3-channel analog inputs, including 2-way 0~10V / 0~20mA voltage and current options, a way to support -10~+10 V input
	output terminal	2-way switch output terminal, which supports a maximum road speed 100KHz pulse output. 2 relay output terminals. 2 analog output terminal, and optional voltage and current.
Featured functions	<p>Parameter copy, parameter backup, flexible parameter displayed & hidden. Common DC bus (Contains below 30 KW) . Various master & auxiliary command and switchover. Reliable speed search started. A variety of Accel / Decel curves programmable. Timing control, fixed length control, count function. Three faults recorded. Over excitation brake, overvoltage stall protection programmable, under voltage stall protection programmable, restart upon power loss. Four kinds of Accel/Decel time. Motor thermal protection. Flexible fan control. Process PID control, simple PLC, 16-step speed control programmable. Wobble frequency control. Multi-functional key programmable, field-weakening control. High-precision torque control, V/f separated control, torque control at sensor-less vector control.</p>	
Protection function	Provide fault protection dozen: Overcurrent, Overvoltage, Undervoltage, Overtemperature, Overload Etc Protection.	
Display and keyboard	LED Display	Display Parameters
	Key lock and function selection	Realize some or all of the keys locked, scope definition section keys to prevent misuse
	Run and stop monitoring information	In the run or stop can be set to monitor U00 group four objects were.
Environment	Place of operation	Indoors, no direct sunlight, free from dust, corrosive gases, flammable gases, oil mist, water vapor, water drop and salt, etc.
	Altitude	0~2000m De-rate 1% for every 100m when the altitude is above 1000 meters
	Ambient	-10℃~40℃

	temperature	
	Relative humidity	5~95%, no condensation
	Vibration	Less than 5.9m/s ² (0.6g)
	Storage temperature	-20℃~+70℃
Others	Efficiency	Rated power≥93%
	Installation	Wall-mounted or Flange mounting
	IP grade	IP20
	Cooling method	Fan cooled

1.4 Configuration, Mounting Dimensions and Weight

◆0.7~2.2KW Dimensions and wall mounting dimensions

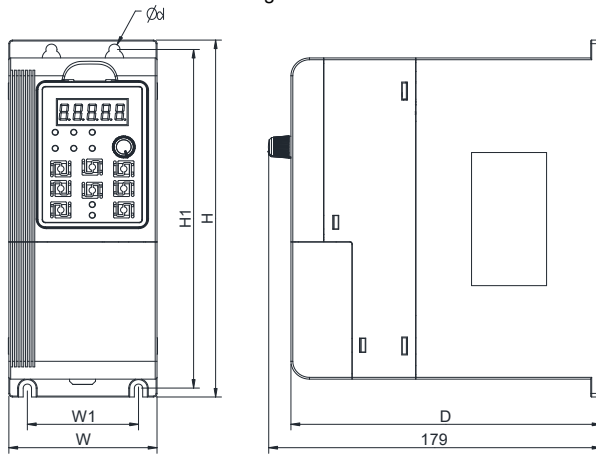

Fig 1-6 0.7~4.0kW Wall installation diagram

Model NO.	External and installation dimensions (mm)						Weight (Kg)
	W	W1	H	H1	D	Mounting Hole Diameter	
3-Phase:380V, 50/60Hz			Range:-15%~+30%				
FR500A-4T-0.7G/1.5PB	80	60	200	190	167	6	1.34
FR500A-4T-1.5G/2.2PB							
FR500A-4T-2.2G/4.0PB							

*Note:

1. The model of FR510A series inverter only needs to replace FR500A in the above table with FR510A.

◆4~22kW Dimensions and wall mounting dimensions:

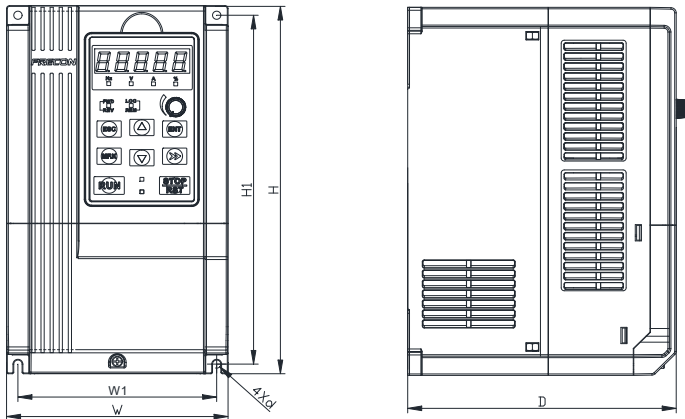

Fig 1-7 4~22kW Wall installation diagram

Model NO.	External and installation dimensions (mm)						Weight (Kg)
	W	W1	H	H1	D	Mounting Hole Diameter	
3-Phase:380V, 50/60Hz Range:-15%~+30%							
FR500A-4T-4.0G/5.5PB	116.6	106.6	186.6	176.6	175	4.5	2.5
FR500A-4T-5.5G/7.5PB							
FR500A-4T-7.5G/011PB	146	131	249	236	190 (177)	5.5	3.9
FR500A-4T-011G/015PB							
FR500A-4T-015G/018PB	198	183	300	287	197 (185)	5.5	6.2
FR500A-4T-018G/022PB							
FR500A-4T-022G/030PB							

*Note:

1. The model of FR510A series inverter only needs to replace FR500A in the above table with FR510A.

2. In the FR510A series inverter structure size table, the dimensions of the old version are in parentheses

◆ 30~280kW Dimensions and wall mounting dimensions:

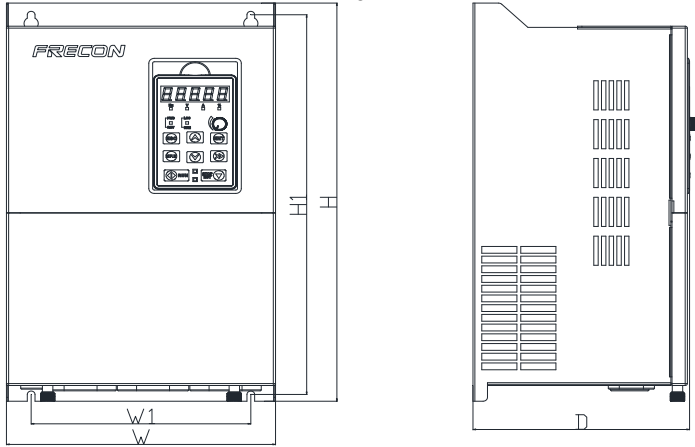

Fig 1-8 30~280KW Wall installation diagram

Model NO.	External and installation dimensions (mm)						Weight (Kg)
	W	W1	H	H1	D	Mounting Hole Diameter	
3-Phase:380V, 50/60Hz Range:-15%~+30%							
FR500A-4T-030G/037PB	250 (245)	200 (200)	432 (410)	411 (391)	227 (200)	7 (7)	12.9 (11.8)
FR500A-4T-037G/045P	250 (300)	200 (200)	432 (485)	411 (466)	227 (226)	7 (7)	12.9 (15)
FR500A-4T-045G/055P	300	200	485	466	226	7	15
FR500A-4T-055G/075P							
FR500A-4T-075G/090P	310	200	620	601	280	9.5	26
FR500A-4T-090G/110P							
FR500A-4T-110G/132P							
FR500A-4T-132G/160P	310	200	650	620	350	11.5	45
FR500A-4T-160G/185P	400	300	750	724	300	11.5	68
FR500A-4T-185G/200P	500	300	855	822	370	12	112
FR500A-4T-200G/220P							
FR500A-4T-220G/250P							
FR500A-4T-250G/280P	540	340	924.5	896	380	12	120
FR500A-4T-280G/315P							

*Note:

In the FR510A series inverter structure size table, the dimensions of the old version are in parentheses

◆ 315~400kW Dimensions and wall mounting dimensions:

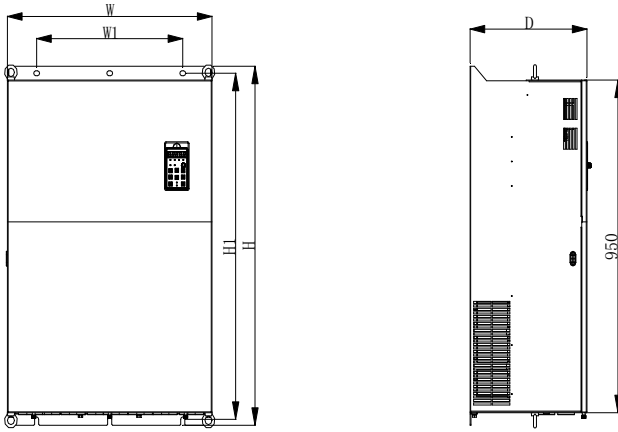

Fig 1-8 315~400KW Wall installation diagram

Model NO.	External and installation dimensions (mm)						Weight (Kg)
	W	W1	H	H1	D	Mounting Hole Diameter	
3-Phase:380V, 50/60Hz Range:-15%~+30%							
FR500A-4T-315G/355P	700	500	1025.5	988.5	390	14	195
FR500A-4T-355G/400P	(620)	(400)	(996)	(963)		(12)	(133)
FR500A-4T-400G/450P	700	500	1025.5	988.5	390	14	195

*Note:

In the FR510A series inverter structure size table, the dimensions of the old version are in parentheses

◆ 450~560kW Dimensions and wall mounting dimensions:

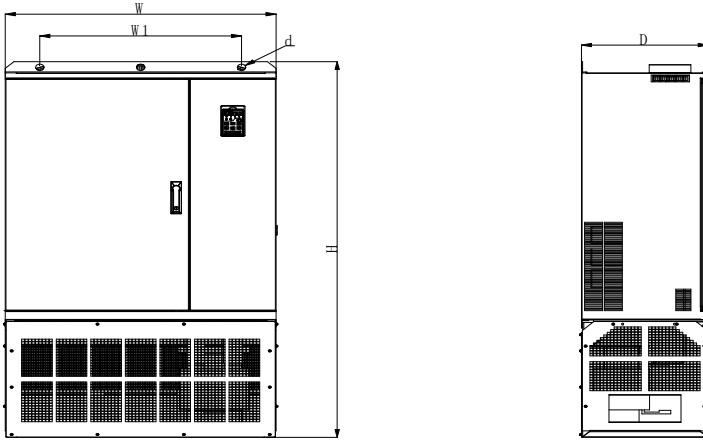

Fig 1-8 450~560KW Wall installation diagram

Model NO.	External and installation dimensions (mm)						Weight (Kg)
	W	W1	H	H1	D	Mounting Hole Diameter	
3-Phase:380V, 50/60Hz Range:-15%~+30%							
FR500A-4T-450G/500P	940 (700)	700 (500)	1684 (1025.5)	- (988.5)	440 (390)	30 (14)	(195)
FR500A-4T-500G/560P	940	700	1684	-	440	30	
FR500A-4T-560G/630P							

*Note:

1. The model of FR510A series inverter only needs to replace FR500A in the above table with FR510A.
2. The data in parentheses in the above table is the size of previous version scheme.
3. In the FR510A series inverter structure size table, the dimensions of the old version are in parentheses

1.5 External Dimensions of Keypad

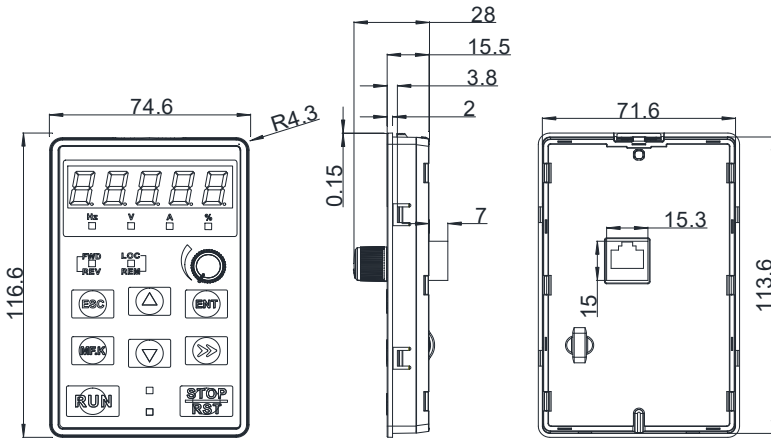
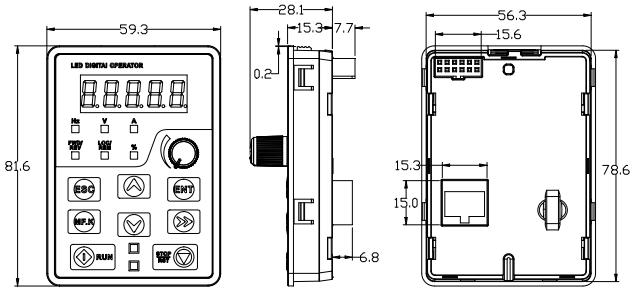

External keyboard installation instruction:

1. first install the panel according to inverter's power range corresponding to the size of hole as shown on scheme 1-12,
2. After that insert keyboard pad into the mounting panel and then insert the keyboard module into the keyboard pad. (Before removing the keyboard pad, first remove the keyboard, then remove as shown in the scheme) .

External keyboard installation:

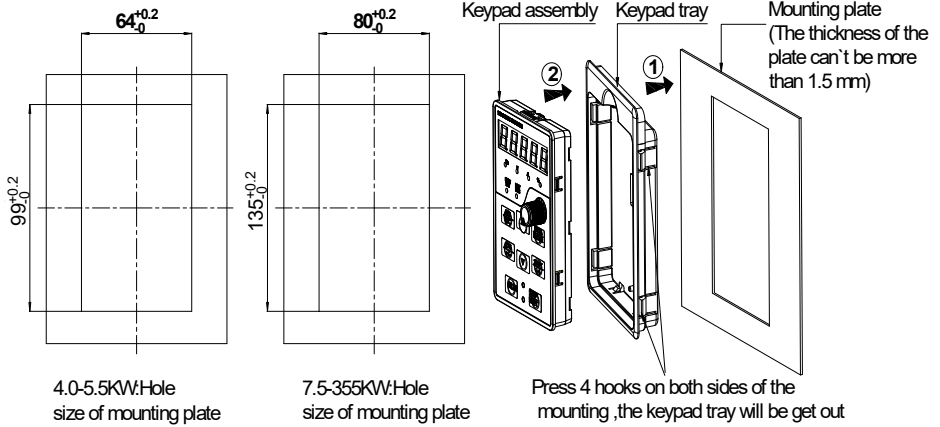

Fig 1-13 4.0~450KW External keyboard installation hole size diagram

Chapter 2 Wiring and Terminals

2.1 Wiring way

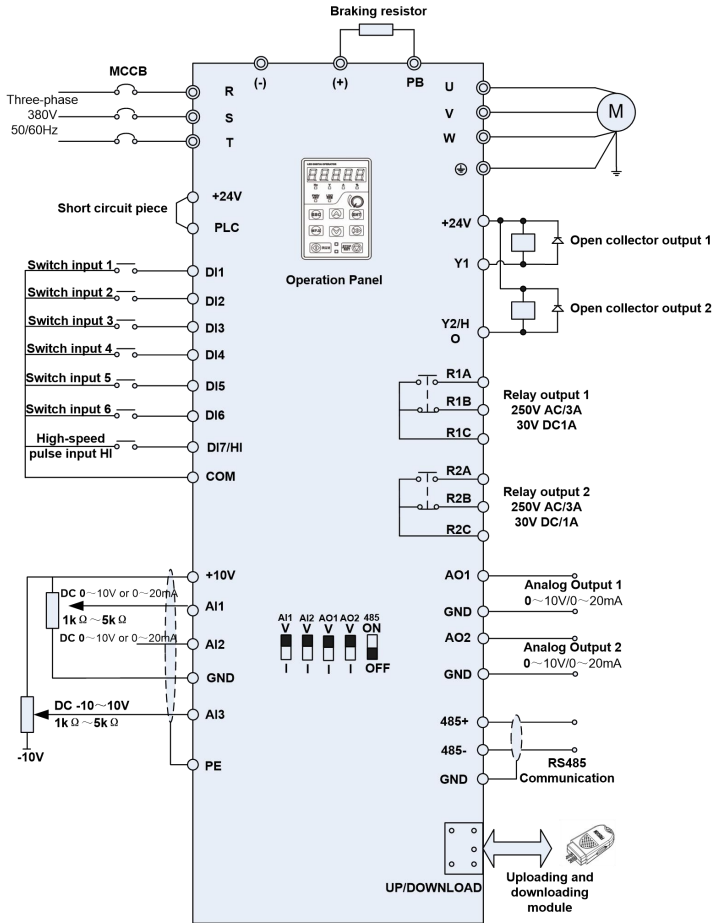

Fig.2-1 FR500A&FR510A Inverter wiring diagram

Remarks:

- 1) ⊙ refers to main circuit terminals, ○ refers to control circuit terminals.
- 2) User selects braking resistor based on real needs. Please refer to the braking resistor Selection Guide.
- 3) Signal cable and power cable should be separated. Try to cross control cable and power cable in 90° if needed. The best selection of analog signal lines shielded twisted pair, Power cables use shielded three-core cable (The specifications of the motor cable than ordinary freshman profile) or Comply with manual drive.

2.2 Terminal Configuration

2.2.1 Main Circuit Terminals

◆0.7~2.2kW Main Circuit Terminals

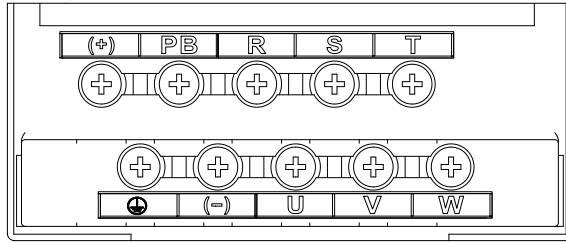

Fig.2-2 0.7~2.2kW Schematic of main circuit terminals

◆4~5.5kW Main Circuit Terminals

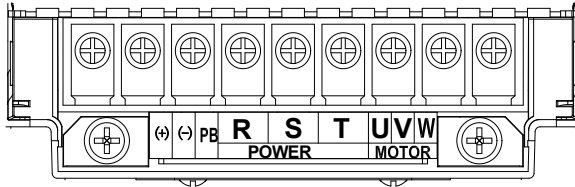

Fig.2-3 4~5.5kW Schematic of main circuit terminals

◆7.5~22kW Main Circuit Terminals

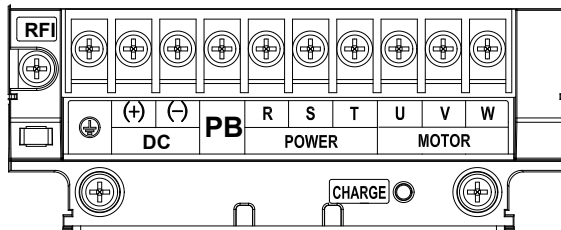

Fig.2-4 7.5~22kW Schematic of main circuit terminals

◆ 30~37KW Main Circuit Terminals

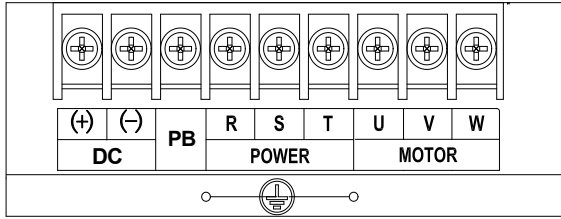

Fig.2-5 30~37kW Schematic of main circuit terminals

◆ 45~90KW Main Circuit Terminals:

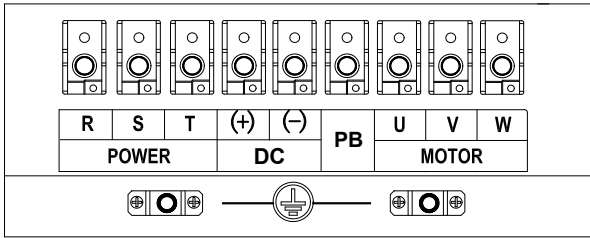

Fig.2-6 45~90kW Schematic of main circuit terminals

◆ 110~132KW , 250~280KW ,315~450KW Main Circuit Terminals:

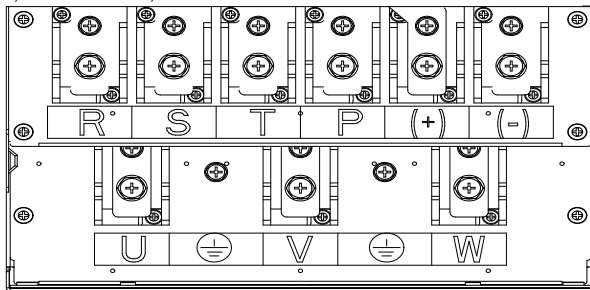

Fig.2-7 110~132KW , 250~280KW ,315~450KW Main Circuit Terminals

◆ 160~220KW Main Circuit Terminals:

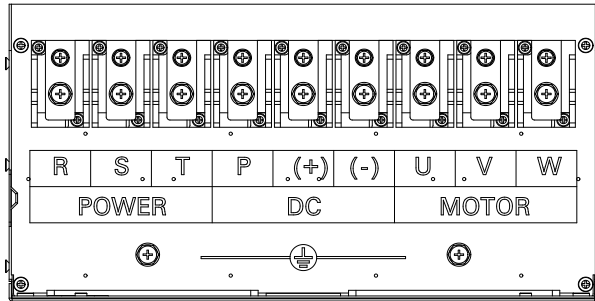

Fig.2-9 160~220KW Main Circuit Terminals

Main circuit terminal functions

Terminal marks	Designation and function of terminals.
R, S, T	AC power input terminals for connecting to 3-phase AC380V power supply.
U, V, W	AC output terminals of inverter for connecting to 3-phase induction motor.
(+), (-)	Positive and negative terminals of internal DC bus.
PB	Positive and negative terminals of internal DC bus. Connecting terminals of braking resistor. One end connected to + and the other to PB.
⊕	Grounding terminal.

Remarks: No phase sequence requirements on wiring of the input side of inverter. Wiring Precautions:

1) Power input terminals R, S, T

◆ The cable connection on the input side of the AC drive has no phase sequence requirement.

2) DC bus (+), (-)

◆ Terminals (+) and (-) of DC bus have residual voltage after the AC drive is switched off. After indicator CHARGE goes off, wait at least 10 minutes before touching the equipment. Otherwise, you may get electric shock.

◆ Do not connect the braking resistor directly to the DC bus. Otherwise, it may damage the AC drive and even cause fire.

3) Braking resistor connection terminals (+), PB

◆ The cable length of the braking resistor shall be less than 5 m. Otherwise, it may damage the AC drive.

4) AC drive output terminals U, V, W

◆ The capacitor or surge absorber cannot be connected to the output side of the AC drive. Otherwise, it may cause frequent AC drive fault or even damage the AC drive.

If the motor cable is too long, electrical resonance will be generated due to the impact of distributed capacitance. This will damage the motor insulation or generate higher leakage current, causing the AC drive to trip in overcurrent protection. If the motor cable is greater than 100 m long, an AC output reactor must be installed close to the AC drive.

5) Terminal ⊕ PE

◆ This terminal must be reliably connected to the main earthing conductor. Otherwise, it may cause electric shock, mal-function or even damage to the AC drive.

◆ Do not connect the earthing terminal to the neutral conductor of the power supply.

2.2.2 Control circuit terminals

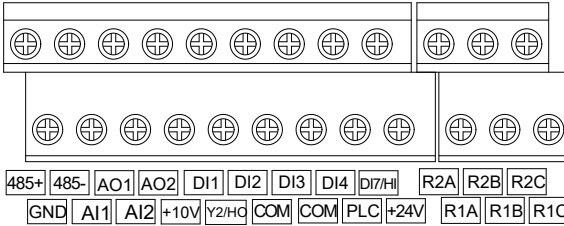

Fig.2-10a control circuit terminals (0.7~2.2kW)

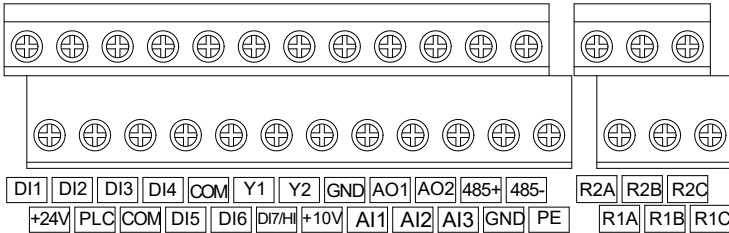



Fig.2-10b Control circuit terminals(>2.2KW)

Table 3-1 Description of control circuit terminals

Type	Terminal	Name	Function Description
Power supply	+10V-GND	External +10 V power supply	Provide +10 V power supply to external unit. Generally, it provides power supply to external potentiometer with resistance range of 1~5 kΩ. Maximum output current: 10 mA
	+24V-COM	External +24V power supply Applying to Overvoltage Category II circuit	Provide +24 V power supply to external unit. Generally, it provides power supply to DI/Do terminals and external sensors. Maximum output current: 200 mA
	PLC	Input terminal of external power supply	Connect to +24 V by default. When DI1-DI7 need to be driven by external signal, PLC needs to be connected to external power supply and be disconnected from +24 V.
Analog input	AI1-GND	Analog input 1	Input voltage range: DC 0~10V/0~20mA, decided by toggle switches AI1, AI2 on the control board Impedance: 250 kΩ (voltage input), 250 Ω (current input)
	AI2-GND	Analog input 2	
	AI3-GND	Analog input 3	Input Voltage Range: DC -10~+10V Input impedance:250kΩ
Switch input	DI1- COM	Switch input terminals 1	Maximum input frequency:200Hz Impedance:2.4kΩ Voltage range for level input:9V~30V
	DI2- COM	Switch input terminals 2	
	DI3- COM	Switch input terminals 3	
	DI4- COM	Switch input	

		terminals 4	
	DI5- COM	Switch input terminals 5	
	DI6- COM	Switch input terminals 6	
	DI7/HI-COM	Switch input terminals 7 OR High-speed pulse input	
Analog output	AO1-GND	Analog output terminal 1	Output voltage range:DC 0~10V/0~20mA, decided by toggle switches
	AO2-GND	Analog output terminal 2	AO1, AO2 on the control board Impedance requirements \geq 10k Ω
Switch output	Y1-COM	Open collector output 1	Voltage range:0~24V Current range:0~50mA
	Y2/HO-COM	Open collector output 2 OR High-speed pulse output	Besides features of Y1, it can be used for High-speed pulse output channels. The maximum output frequency:100kHz
Relay output	R1A-R1C	Normally open terminal	Contact driving capacity: AC250V, 3A, COS ϕ =0.4. DC 30V, 1A
	R1B-R1C	Normally closed terminal	
	R2A-R2C	Normally open terminal	
	R2B-R2C	Normally closed terminal	
485 Communication	485+-485-	485 Communication Terminals	Rate: 4800/9600/19200/38400/57600/ 115200bps Termination resistor is set by the toggle switch on the control panel RS485
	GND	485 Communication shielded ground	
Shield	PE	Shield Ground	Ground terminal for shield
Auxiliary Interface		External operation panel interface	Use standard network cable Maximum cable distance: 50m

Chapter 3 Operation and Display

3.1 Introduction of Keypad

As a human-machine interface, you can modify the parameters, monitor the working status and start or stop the inverter by operating the keypad. Its appearance and function area as shown in the following figure:



Fig.3-1 Keypad

3.1.1 Key and potentiometer Functions on keypad

There are 8 keys and a potentiometer on the keypad, whose functions are as shown in Table 4-1.



Table 3-1 Key functions on keypad

Symbol	Name	Function
	Escape	Enter or exit Level I menu
	Enter	Enter the menu interfaces level by level, and confirm the parameter setting
	Increment	Increase data or function code
	Decrement	Decrease data or function code
	Shift	Select the displayed parameters in turn in the stop or running state, and select the digit to be modified when modifying parameters
	Multifunction	Perform function switchover (such as jog run and quick switchover of command source or direction) according to the setting of F16.00
	potentiometer	With the same function as AI1/AI2
	Run	Start the inverter in the keypad control mode
	Stop/Reset	Stop the inverter when it is in the running state and perform the reset operation when it is in the fault state. The functions of this key are restricted in F16.01.
	Key combinations	The inverter will free stop when the run and stop key are pressed simultaneously

3.1.2 Keypad Indicators

There are 8 Indicators on the keypad, whose descriptions are as shown in Table 3-2.

Table 3-2 Description of indicators

Indicator	Name	Meaning
Unit	Hz	Frequency ON: currently displayed parameter is frequency
	V	Voltage ON: currently displayed parameter is voltage
	A	Current ON: currently displayed parameter is current
	%	Percentage ON: currently displayed parameter is percentage
	All off	Other unit Other unit or no unit
State	FWD/REV	Forward or reverse ON: the drive is running reverse OFF: the drive is running forward Flash: dormant state
	LOC/REM	Keypad, terminals or communication ON: Terminal control OFF: Keypad control Flash: Communication control
	 (Green border)	Running state ON: Running state OFF: Stopped state Flash: In process of stop
	 (Red border)	Fault state ON: Fault state OFF: Normal state Flash: Warning state

3.1.3 Keypad digital display

The keypad has five LED (digital) display, it can display a given frequency, output frequency and other parameters, monitoring data and alarm code. Table 3-3 shows meanings of the characters displayed on Keypad.

Table 3-3 Meanings of displayed characters

Displayed character	Character Meaning	Displayed character	Character Meaning	Displayed character	Character Meaning	Displayed character	Character Meaning
0	0	A	A	I	I	S	S
1	1	b	b	J	J	T	T
2	2	C	C	K	K	t	t
3	3	c	c	L	L	U	U
4	4	d	d	N	N	u	u
5	5	E	E	n	n	y	y
6	6	F	F	o	o	-	-
7	7	G	G	p	p	8.	8.
8	8	H	H	q	q	.	.
9	9	h	h	r	r		

3.1.4 Message status

A message appears when the state of completion of certain operations. Prompt message characters and their meanings are specified in Table 3-4.

Table 3-4 Prompt characters

Prompt symbol	Meaning	Prompt symbol	Meaning
Err00~Err99	Fault type	TUNE	Motor parameter identification in process
A00~A99	Alarm type	-END-	Write parameter

3.2 Viewing and Modifying Function Codes

The keypad of the FR500A&FR510A adopts three-level menu.

The three-level menu consists of function code group (Level I), function code (Level II), and function code setting value (level III), as shown in the figure 3-2.

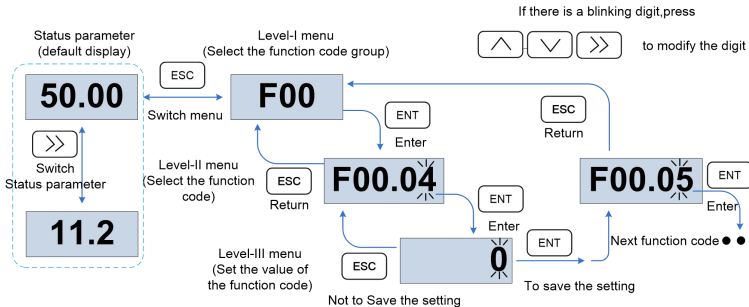

Fig.3-2 Operation procedure on the keypad

Explanation: In the level III menu, you can press the ESC key or ENT key to return to the level II menu. The difference is: If you do not have to modify the function code setting, press ENT will be automatically transferred to the next function code; If the function code settings are modified, it will display menu "-END-" 1 second when press ENT key, and redisplay the current function code settings, and it will be automatically transferred to the next function code when press the ENT key again. Press the ESC key to abandon the current parameter changes directly returns the current function code in level II.

Here is an example of changing the value of F01.02 to 15.00 Hz.

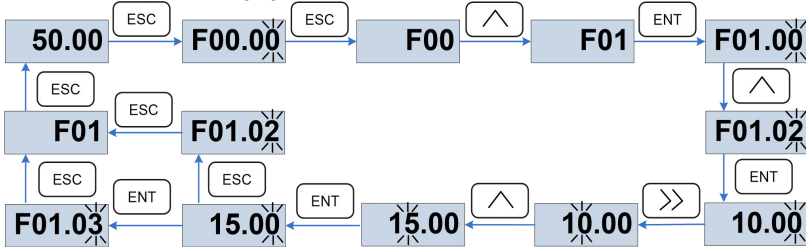

Fig.3-3 Example of changing the parameter value

In Level III menu, if the parameter has no blinking digit, it means that the parameter cannot be modified. This may be because:

- (1) Such a function code is only readable, such as, AC drive model, actually detected parameter and running record parameter.
- (2) Such a function code cannot be modified in the running state and can only be changed at stop.

3.3 Viewing Status Parameters

There are stop state parameters and running state parameters.

It has 4 status parameters in the stop or running state. You can press ">>" on the keypad to display status parameters. Which parameters are displayed is determined by the values of F16.03~F16.06 (Running state parameters 1~4), F16.07~F16.10 (stop state parameters 1~4), it can select the U00 group.

3.4 Motor Auto-tuning

Tuning is valid only when the keyboard command mode. Set tuning mode (stationary or rotating), press the ENT key to confirm, the keyboard will display TUNE, then press the RUN key, the inverter will drive motor acceleration and deceleration, positive inversion operation, and the run indicator lights. Tuning duration of about two minutes, when the display TUNE message disappears, returning to normal parameter display status, which means that the tuning is completed.

3.5 Password Setting

The inverter provides password protection function, it is set a user's password when F00.00 set to nonzero. If five minutes without operating the keypad, the password protection is effective, and the keypad will show "-----", then the user must enter the correct password to enter the regular menu, otherwise inaccessible.

There are three ways a user password into force:

Method 1: Set F00.00 parameter to nonzero, then press the ESC + ENT key.

Method 2: Set F00.00 parameter to nonzero, then do not use the keypad within five minutes.

Method 3: Set F00.00 parameter to nonzero, then completely power down and then power.

If you want to cancel the password protection functions, only through a password to enter, and set F00.00 to 0.

3.6 Keypad lock

3.6.1 Keypad lock

The following three methods to any one immediately lock all or part of the keypad buttons; see the definition of the function code F16.02.

Method 1: Set F16.02 parameter to nonzero, then press the ESC + ENT key.

Method 2: Set F16.02 parameter to nonzero, and then do not use the keypad within five minutes.

Method 3: Set F16.02 parameter to nonzero, then completely power down and then power.









3.6.2 Keypad unlock

Press the ESC + >> keys to unlock. Unlocking operation does not change the value of F16.02, That means when Meet the keypad locking conditions, the keypad will be locked again. If you want the control panel no longer be locked, after unlocking the F16.02 must change the value to 0.

3.7 Shortcut menus function code description

Factory setting mode is changed to be shortcut menu mode (F00.01=1) in the software version above V1.07, group 17 is for the parameters of shortcut menu.

The difference of display between shortcut manual and basic menu is in the second level menu, please refer to below the details of difference and the switching method.

Menu mode	Shortcut menu	Basic menu
Display difference	F01.01. The last digit of F01.01. function code is with radix point, no flashing	F01.01 F01.01 function code is without radix point, and flashing
Function difference	1. Press  or  for up-down switch in F17 function code 2.  can't return back to first level menu	1. Press  or  up-down switch in sequency. 2. Press  return back to first level menu
Switch	Method 1. Setting F00.01=0 to basic menu Method 2. Long Press  when display second level menu, switch to basic menu automatically	Method 1. Setting F00.01 to shortcut menu Method 2. Long press  when display second level menu, switch to shortcut menu automatically

If the shortcut menu is not enough, user can reset the shortcut menu, refer to group F17 for details.

Chapter 4 List of Parameter

Group F00~F17 are standard function parameters. Group U00 is status monitoring parameters. Group U01 is fault record parameters.

The symbols in the function code table are described as follows:

"△" means the value of this parameter can be modified in stop and running status of drive;

"×" means the value of this parameter cannot be modified when drive is running;

"⊙" means this parameter is a measured value that cannot be modified;

Default: The value when restored to factory default. Neither measured parameter value nor recorded value will be restored.

Setting Range: the scope of setting and display of parameters

FR500A&FR510A parameter groups are listed below:

Category	Parameter Group
System Parameters	F00: System Parameters
Basic Parameters	F01: Frequency Command
	F02: Start/Stop Control Start/Stop Control
	F03: Accelerate/Decelerate Parameters
Input & Output Terminals	F04: Digital Input
	F05: Digital Output
	F06: Analog and Pulse Input
	F07: Analog and Pulse Output
	F22: Virtual IO
Motor and Control Parameters	F08: Parameters of Motor 1
	F09: V/f Control Parameters of Motor 1
	F10: Vector Control Parameters of Motor 1
	F18: Parameters of Motor 2 (FR510A only)
	F19: V/f Control Parameters of Motor 2 (FR510A only)
	F20: Vector Control Parameters of Motor 2 (FR510A only)
Protection Parameters	F11: Protection Parameters
Application Parameters	F12: Multi-Reference and Simple PLC Function
	F13: Process PID
	F14: Swing Frequency, Fixed Length, Count and Wakeup
	F21: Position control. (FR510A only)
Communication Parameters	F15: Communication Parameters
Keys and Display of Keypad Parameters	F16: Keys and Display of Keypad Parameters
User-defined Display Parameters	F17: User-defined Display Parameters
Monitoring Parameters	U00: Status monitoring
	U01: Fault record

4.1 Five LED (digital) display indicators

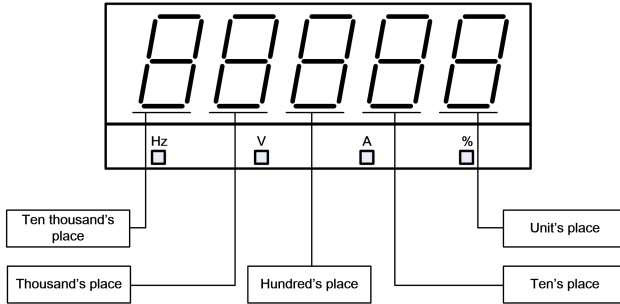

Fig.4-1 LED indicators

4.2 Standard Function Parameters

Table 4-1 Standard Function Parameters

Param	Parameter Name	Setting Range	Default	Attr	RAM Address
Group F00: System Parameters					
F00.00	Setting of User Password	0~65535	0	×	0000
F00.01	Display of Parameters	0: Display all parameters 1: Only display F00.00, F00.01 and user-defined parameters F17.00~F17.29	0	×	0001
		2: Only display F00.00, F00.01, and the parameters different with factory default			
F00.02	Parameter Protection	0: All parameter programmable 1: Only F00.02 and this parameter programmable	0	×	0002
F00.03	G/P type display	0: G type (constant torque load) 1: P type (variable torque load e.g. fan and pump)	0	×	0003
F00.04	Parameter Initialization	0: No operation 1: Restore all parameters to factory default (excluding motor parameters) 2: Clear fault record 3: Back up current user parameters 4: Restore user backup parameters 5: Restore factory default. (include motor parameter) 6: Power consumption zero clearing (U00.35)	0	×	0004
F00.06	Parameter editing mode	0: Editable via keypad and RS485. 1: Editable via keypad 2: Editable via RS485	0	×	0006
F00.07	Motor selection	0: Motor 1 1: Motor 2	0	×	0007
F00.08	Motor 1 control mode	Unit's place: Motor 1 control mode 0: V/F control 1: Sensor-less vector control 1 2: Sensor-less vector control 2 3: Vector control with PG card	1	×	0008

FR500A&FR510A Series Vector Control Inverter

		Ten's place: Motor 2 control mode 0: V/F control 1: Sensor-less vector control 1 2: Sensor-less vector control 2 3. Vector control with PG card			
F00.09	DI7/HI input mode	0: Digital input terminal 7 1: Pulse input	0	×	0009
F00.10	AI1\AI2\AI3 input mode	Unit's place: AI1 0: Analog input 1: Digital input Ten's place: AI2 (same as AI1) Hundred's place: AI3 (same as AI1)	000	×	000A
F00.11	Y2/HO input mode	0: Digital Output terminal 2 1: Pulse output	0	×	000B
F00.12	PWM optimization	Unit's place: PWM modulation mode 0: Fixed carrier 1: Random carrier 2: Derating of fixed carrier 3: Derating of random carrier Ten's place: PWM modulation mode 0: Seven-segment mode 1: Five-segment mode 2: Five-segment and seven-segment automatic switchover Hundred's place: over-modulation coefficient 0: Invalid 1~9: 1.01~1.09 times of over-modulation	500	×	000C
F00.13	Carrier frequency	0.700~16.000kHz	Model defined	△	000D
F00.14	Upper carrier frequency	0.700~16.000kHz	8.000kHz	×	000E
F00.15	Lower carrier frequency	0.700~16.000kHz	2.000kHz	×	000F
F00.16	Output voltage	5.0~150.0%	100.0%	×	0010
F00.17	AVR	0: Disabled 1: Enabled 2: AVR is disabled if the DC bus voltage > the rated voltage of DC bus, and it will be enabled if the DC bus voltage ≤ the rated voltage of DC bus.	1	×	0011
F00.18	Fan control	0: Run at power-on 1: Fan working during running	1	×	0012
F00.19	Factory password	0~65535	0	×	0013
F00.20	Inverter rated power	0.2~1000.0kW	Model defined	⊙	0014
F00.21	Inverter rated voltage	60~660V	Model defined	⊙	0015
F00.22	Inverter rated	0.1~1500.0A	Model	⊙	0016

	current		defined		
F00.23	Software version	0.00~655.35	Model defined	⊖	0017
F00.24	Dealer password	0~65535	0	×	0018
F00.25	Run time setting	0~65535h(0: Invalid)	0h	×	0019
Group F01: Frequency Command					
F01.00	Frequency source selection	0: Master frequency source	0	×	0100
		1: Auxiliary frequency source			
		2: Master +Auxiliary			
		3: Master - Auxiliary			
		4: MAX{Master, Auxiliary }			
		5: MIN {Master, Auxiliary }			
		6: AI1 (Master + Auxiliary)			
F01.01	Master Frequency Command Source	0:Master digital setting (F01.02)	1	×	0101
		1: keypad potentiometer			
		2: Analog input AI1			
		3: Communication			
		4: Multi-reference			
		5: PLC			
		6: Process PID output			
		7: X7/HI pulse input			
		8: AI2			
9: AI3					
F01.02	Master Frequency Digital setting	0.00~Fmax	50.00Hz	△	0102
F01.03	Auxiliary Frequency Command Source	0: Auxiliary digital setting (F01.04)	0	×	0103
		1: keypad potentiometer			
		2: Analog input AI1			
		3: Communication			
		4: Multi-reference			
		5: PLC			
		6: Process PID output			
		7: X7/HI pulse input			
		8: Analog input AI2			
9: Analog input AI3					
F01.04	Auxiliary frequency digital setting	0.00~Fmax	50.00Hz	△	0104
F01.05	Auxiliary frequency range	0: Relative to maximum frequency	0	×	0105
		1: Relative to master frequency			
F01.06	Auxiliary frequency coeff	0.0~1000.0%	100.0%	△	0106
F01.07	Jog frequency	0.00~Fmax	5.00Hz	△	0107
F01.08	Maximum frequency	20.00~600.00Hz	50.00Hz	×	0108
F01.09	Upper limit frequency	Fdown~Fmax Lower limit frequency~maximum frequency	50.00Hz	×	0109
F01.10	Lower limit frequency	0.00~Fup	0.00Hz	×	010A
F01.11	Operation when	0: Run at lower limit frequency	0	×	010B

FR500A&FR510A Series Vector Control Inverter

	command frequency lower than lower limit frequency	1: Run at 0 Hz would be activated after the time delay set by F01.12			
F01.12	Lower limit frequency running time	0.0~6000.0s	60.0s	×	010C
F01.13	Up to this frequency, start frequency compensation	0.00~600.00Hz	50.00Hz	△	010D
F01.14	Frequency compensation per 50Hz	0.00~50.00Hz	0.00Hz	△	010E
Group F02: Start/Stop Control					
F02.00	Run command	0: Keypad control (LED off)	0	×	0200
		1: Terminal control (LED on)			
F02.01	Running direction	0: Forward	0	△	0201
		1: Reverse			
F02.02	Reverse-proof action	0: Reverse enabled	0	×	0202
		1: Reverse disabled			
F02.03	Dead time between forward and reverse	0.0~6000.0s	0.0s	×	0203
F02.04	Start mode	Unit's place: Start Mode 0:Start directly 1:Rotational speed track and restart	00000	×	0204
		Ten's place: short-circuit detection function 0:Ungrounded short-circuit detection 1:Grounding short-circuit detection before the first starts 2:Grounding short-circuit detection before each starts			
		Hundred's place: Speed tracking 0:Track from zero speed 1:Track from max frequency			
		Thousand's place: Select if Jog function takes the priority 0:Disable 1:Enable			
		Ten thousand's place: Tracking direction 0: Last direction when stop 1: Positive direction 2: Negative direction 3: Starting direction			
F02.05	Start frequency	0.00~10.00Hz	0.00Hz	×	0205
F02.06	Startup frequency holding time	0.0~100.0s	0.0s	×	0206
F02.07	Startup DC brakin current	0.0~150.0%	0.0%	×	0207

F02.08	DC braking time at start	0.0~100.0s	0.0s	×	0208
F02.09	Speed search current	0.0~180.0%	130.0%	△	0209
F02.10	Sped search decel time	0.0~10.0s	1.0s	×	020A
F02.11	Sped search coefficient	0.01~5.00	0.30	△	020B
F02.12	Stop mode	0: Ramp to stop	0	×	020C
		1: Coast to stop			
F02.13	Initial frequency of stop DC braking	0.01~50.00Hz	2.00Hz	×	020D
F02.14	Stop DC braking current	0.0~150.0%	0.0%	×	020E
F02.15	Waiting time of stop DC braking	0.0~30.0s	0.0s	×	020F
F02.16	Stop DC braking time	0.0~30.0s	0.0s	×	0210
F02.17	Dynamic brake	0: Disabled	0	×	0211
		1: Enabled			
		2: Enabled at running			
		3: Enabled at deceleration			
F02.18	Voltage of dynamic braking	480~800V	700V	×	0212
F02.19	Brake use ratio	5.0~100.0%	100.0%	×	0213
F02.20	0Hz output selection	0: No voltage output	0	×	0214
		1: Voltage output			
F02.21	Auto-start of power-on again	0: Invalid	0	△	0215
		1: Valid			
F02.22	Waiting time between auto-start and power-on again	0.0~10.0s	0.5s	△	0216
Group F03: Accel/Decel Parameters					
F03.00	Accel time 1	0.0~6000.0s	15.0s	△	0300
F03.01	Decel time 1	0.0~6000.0s	15.0s	△	0301
F03.02	Accel time 2	0.0~6000.0s	15.0s	△	0302
F03.03	Decel time 2	0.0~6000.0s	15.0s	△	0303
F03.04	Accel time 3	0.0~6000.0s	15.0s	△	0304
F03.05	Decel time 3	0.0~6000.0s	15.0s	△	0305
F03.06	Accel time 4	0.0~6000.0s	15.0s	△	0306
F03.07	Decel time 4	0.0~6000.0s	15.0s	△	0307
F03.08	Jog accel time	0.0~6000.0s	15.0s	△	0308
F03.09	Jog decel time	0.0~6000.0s	15.0s	△	0309
F03.10	Accel/Decele curve	0: Linear Accel/Decel	0	×	030A
		1: S-curve Accel/Decel			
F03.11	Initial segment time of acceleration of S curve	0.0~6000.0s	0.0s	×	030B
F03.12	Time unit of	0: 0.1s	0	×	030C

FR500A&FR510A Series Vector Control Inverter

	acceleration and deceleration	1: 0.01s			
F03.13	Frequency switchover point between acceleration time 1 and acceleration time 2	0.00~Fmax	0.00Hz	×	030D
F03.14	Frequency switchover point between deceleration time 1 and deceleration time 2	0.00~Fmax	0.00Hz	×	030E
F03.15	End segment time of acceleration of S curve	0.0~6000.0s	0.0s	×	030F
F03.16	Initial segment time of deceleration of S curve	0.0~6000.0s	0.0s	×	0310
F03.17	End segment time of deceleration of S curve	0.0~6000.0s	0.0s	×	0311
Group F04 Digital Input					
F04.00	Function of terminal DI1	00: No function 01: Running forward (FWD) 02: Running reverse (REV) 03: Three-wire control 04: JOG forward 05: JOG reverse 06: Coast to stop 07: Fault reset (RESET) 08: Running suspended 09: External fault input 10: Terminal UP 11: Terminal DOWN 12: UP/DOWN (including \wedge/\vee key) adjustment clear 13: Multi-step frequency terminal 1 14: Multi-step frequency terminal 2 15: Multi-step frequency terminal 3 16: Multi-step frequency terminal 4 17: Accel/Decel time determinant 1 18: Accel/Decel time determinant 2 19: Accel/Decel disabled(ramp stop not inclusive) 20: Switch to auxiliary speed setting 21: PLC status reset 22: Simple PLC paused 23: Simple PLC paused 24: PID adjustment direction	1	×	0400
F04.01	Function of terminal DI2		2	×	0401
F04.02	Function of terminal DI3		7	×	0402
F04.03	Function of terminal DI4		13	×	0403
F04.04	Function of terminal DI5		0	×	0406
F04.05	Function of terminal DI6		0	×	0405
F04.06	Function of terminal DI7		0	×	0406
F04.07	Function of terminal AI1		0	×	0407
F04.08	Function of terminal AI2		0	×	0408
F04.09	Function of terminal AI3	0	×	0409	

		<p>25: PID integration paused 26: PID parameter switch 27: Swing frequency pause(output the current frequency) 28: Swing frequency reset(output the central frequency) 29: Run command switched to keypad control 30: Run command switched to terminal control 31: Run command switched to communication control 32: Count input 33: Count clear 34: Length count 35: Length clear 36: DC brake input command at Stop 37: Speed/torque control switch 38: No reverse 39: No forward 40: zero-serve (FR510A only) 41: Enable spindle orientation (FR510A only) 42: Orientation position selection 1 (FR510A only) 43: Orientation position selection 2 (FR510A only) 44: Simple carry origin signal input (FR510A only) 45: FWD carry (FR510A only) 46: REV carry (FR510A only) 47: Carry amount selection terminal 1 (FR510A only) 48: Carry amount selection terminal 2 (FR510A only) 49: Carry amount selection terminal 3 (FR510A only) 70: Position given X7 direction input (FR510A only) 71: Position Pulse Zero Clearing (FR510A only) 72: Forward position offset enable (FR510A only) 73: Reverse position offset enable (FR510A only) 74: Pulse proportion selection of Ho output encoder (FR510A only) 75: Current overrun switching(FR510A only) 76: Carry enable(FR510A only)</p>			
F04.10	Filtering time of digital input terminal	0.000~1.000s	0.010s	△	040A
F04.11	Delay time before terminal DI1 is valid	0.0~300.0s	0.0s	△	040B
F04.12	Delay time before terminal	0.0~300.0s	0.0s	△	040D

FR500A&FR510A Series Vector Control Inverter

	DI2 is valid				
F04.13	Terminal DI1~DI5 positive/negative logic	DI5, DI4, DI3, DI2, DI1 0: Positive logic(Terminals are on at 0V/off at 24V) 1: Negative Logic (Terminals are off at 0V/on at 24V)	00000	×	040C
F04.14	Terminal DI6~AI3 positive/negative logic	AI3, AI2, AI1, DI7, DI6 0: Positive logic 1: Negative Logic	00000	×	040E
F04.15	FWD/REV terminal control mode	0: Two-wire mode 1 1: Two-wire mode 2 2: Three-wire mode 1 3: Three-wire mode 2	0	×	040F
F04.16	Terminal UP/DOWN frequency adjustment control	Unit's place: action when stop 0: Clear 1: Holding Ten's place: action on power loss 0: Clear 1: Holding Hundreds place: integral function 0: No integral function 1: Integral function enabled Thousand's place: Select if it can be reduced to negative frequency 0: Disable 1: Enable Ten thousand's place: Jog action to clear UP/DOWN 0: Not Clear 1: Clear	00001	×	0410
F04.17	Terminal UP/DOWN frequency change step size	0.00~50.00Hz 0.00:Disabled	1.00Hz/200ms	△	0411
F04.18	Terminal action selection when power on	0: Level effective 1: Edge trigger +Level effective(When power on) 2: Edge trigger +Level effective(Every start)	0	×	0412
F04.19	Delay time before terminal DI1 is invalid	0.0~300.0s	0.0s	△	0413
F04.20	Delay time before terminal DI2 is invalid	0.0~300.0s	0.0s	△	0414
Group F05 Digital Output					
F05.00	Y1 output function	00: No output 01: Drive is running	1	×	0500
F05.01	Y2 output function	02: Fault output 03: Frequency-level detection	3		0501
F05.02	Relay 1 output function	FDT1 output 04: Frequency-level detection	2	×	0502
F05.03	Relay 2 output function	FDT2 output 05: Drive in 0Hz running 1(no output at stop)	11	×	0503

		06: Drive in 0Hz running 2(output at stop) 07: Upper limit frequency attained 08: Lower limit frequency attained 09: Frequency attained 10: Inverter is ready to work 11: Drive (motor) overloaded alarm 12: Inverter overheat warning 13: Current running time attained 14: Accumulative power-on time attained 15: Consecutive running time attained 16: PLC cycle completed 17: Set count value attained 18: Designated count value attained 19: Length attained 20: Under load alarm 21: Brake output 22: DI1 23: DI2 24: When reach the range of set frequency(FDT1) 25: Spindle orientation completion (FR510A only) 26: PID feedback loss 27: operation status (inching without output) 28: communication setting (address 2007h) 40: The current exceeds the limit			
F05.04	Y1 output delay time	0.0~6000.0s	0.0s	△	0504
F05.05	Y2 output delay time	0.0~6000.0s	0.0s	△	0505
F05.06	R1 output delay time	0.0~6000.0s	0.0s	△	0506
F05.07	R2 output delay time	0.0~6000.0s	0.0s	△	0507
F05.08	Enabled state of digital output	Unit's place: Y1	0000	×	0508
		0: Positive logic			
		1: Negative logic			
		Ten's place: Y2 (same as unit's place)			
		Hundreds place: Relay 1 output (same as unit's place)			
Thousands place: Relay 2 output (same as unit's place)					
F05.09	Detection width of frequency attained	0.00~20.00Hz	5.00Hz	×	0509
F05.10	FDT1 upper bound	0.00~Fmax	30.00Hz	×	050A
F05.11	FDT1 lower bound	0.00~Fmax	30.00Hz	×	050B
F05.12	FDT2 upper	0.00~Fmax	30.00Hz	×	050C

FR500A&FR510A Series Vector Control Inverter

	bound				
F05.13	FDT2 lower bound	0.00~Fmax	30.00Hz	×	050D
F05.14	Consecutive running time	0.0~6000.0Min 0.0:Disabled	0.0Min	×	050E
F05.15	Accumulative power-on time setting	0~65535h 0:Disabled	0h	×	050F
F05.16	Accumulative running time setting	0~65535h 0:Disabled	0h	×	0510
F05.17	Brake control selection	0: Disabled	0	×	0511
		1: Enabled			
F05.18	Brake opened frequency	Closed frequency ~30.00Hz	2.50Hz	×	0512
F05.19	Brake opened current	0.0~200.0%	0.0%	△	0513
F05.20	Brake open waiting time	0.00~10.00s	0.00s	×	0514
F05.21	Brake open operating time	0.00~10.00s	0.50s	×	0515
F05.22	Brake closed frequency	0.00Hz~opened frequency	2.00Hz	×	0516
F05.23	Brake close waiting time	0.00~10.00s	0.00s	×	0517
F05.24	Brake close operating time	0.00~10.00s	0.50s	×	0518
F05.26	Current overrun 1	0.1~1500.0A	0.0A	△	051A
F05.27	Current overrun 2	0.1~1500.0A	0.0A	△	051B
Group F06 Analog and Pulse Input					
F06.00	Minimum input of curve A11	0.0%~input of inflection point1 of curve A11	1.0%	△	0600
F06.01	Set value corresponding to minimum input of curve A11	-100.0~100.0%	0.0%	△	0601
F06.02	Input of inflection point 1 of curve A11	Minimum input of curve A11~Input of inflection point 2 of curve A11	100.0%	△	0602
F06.03	Set value corresponding to input of inflection point 1 of curve A11	-100.0~100.0%	100.0%	△	0603
F06.04	Input of inflection point 2 of curve A11	Input of inflection point 1 of curve A11~Maximum input of curve A11	100.0%	△	0604
F06.05	Set value corresponding to input of inflection point 2 of curve	-100.0~100.0%	100.0%	△	0605

	AI1				
F06.06	Maximum input of curve AI1	Input of inflection point 2 of curve AI1~100.0%	100.0%	△	0606
F06.07	Set value corresponding to maximum input of curve AI1	-100.0~100.0%	100.0%	△	0607
F06.08	Minimum input of curve AI2	0.0%~input of inflection point1 of curve AI2	1.0%	△	0608
F06.09	Set value corresponding to minimum input of curve AI2	-100.0~100.0%	0.0%	△	0609
F06.10	Input of inflection point 1 of curve AI2	Minimum input of curve AI1~Input of inflection point 2 of curve AI2	100.0%	△	060A
F06.11	Set value corresponding to input of inflection point 1 of curve AI2	-100.0~100.0%	100.0%	△	060B
F06.12	Input of inflection point 2 of curve AI2	Input of inflection point 1 of curve AI2~Maximum input of curve AI2	100.0%	△	060C
F06.13	Set value corresponding to input of inflection point 2 of curve AI2	-100.0~100.0%	100.0%	△	060D
F06.14	Maximum input of curve AI2	Input of inflection point A of curve AI2~100.0%	100.0%	△	060E
F06.15	Set value corresponding to maximum input of curve AI2	-100.0~100.0%	100.0%	△	060F
F06.16	Minimum input of curve AI3	0.0%~input of inflection point1 of curve AI3	0.0%	△	0610
F06.17	Set value corresponding to minimum input of curve AI3	-100.0~100.0%	-100.0%	△	0611
F06.18	Input of inflection point 1 of curve AI3	Minimum input of curve AI1~Input of inflection point 2 of curve AI3	25.0%	△	0612
F06.19	Set value corresponding to input of inflection	-100.0~100.0%	-50.0%	△	0613

FR500A&FR510A Series Vector Control Inverter

	point 1 of curve AI3				
F06.20	Input of inflection point 2 of curve AI3	Input of inflection point 1 of curve AI3~Maximum input of curve AI3	75.0%	△	0614
F06.21	Set value corresponding to input of inflection point 2 of curve AI3	-100.0~100.0%	25.0%	△	0615
F06.22	Maximum input of curve AI3	Input of inflection point A of curve AI3~100.0%	100.0%	△	0616
F06.23	Set value corresponding to maximum input of curve AI3	-100.0~100.0%	100.0%	△	0617
F06.24	Minimum input of curve keypad potentiometer	0.0~Maximum input of curve keypad potentiometer	0.5%	△	0618
F06.25	Set value corresponding to minimum input of curve keypad potentiometer	-100.0~100.0%	0.0%	△	0619
F06.26	Maximum input of curve keypad potentiometer	Minimum input of curve keypad potentiometer~100.0	99.9%	△	061A
F06.27	Set value corresponding to maximum input of curve keypad potentiometer	-100.0~100.0%	100.0%	△	061B
F06.28	A1 terminal filtering time	0.000~10.000s	0.100s	△	061C
F06.29	A2 terminal filtering time	0.000~10.000s	0.100s	△	061D
F06.30	A3 terminal filtering time	0.000~10.000s	0.100s	△	061E
F06.31	Keypad potentiometer filtering time	0.000~10.000s	0.100s	△	061F
F06.32	Minimum input of curve HI	0.00 kHz~Maximum input of curve HI	0.00kHz	△	0620
F06.33	Set value corresponding to minimum input of curve HI	-100.0~100.0%	0.0%	△	0621
F06.34	Maximum input of curve HI	Minimum input of curve HI~100.00kHz	50.00kHz	△	0622
F06.35	Set value	-100.0~100.0%	100.0%	△	0623

	corresponding to maximum input of curve HI				
F06.36	HI terminal filtering time	0.000~10.000s	0.100s	△	0624
Group F07 Analog and Pulse Output					
F07.00	AO1 output function	00: No output 01: Output frequency	1	×	0700
F07.01	AO2 output function	02: Command frequency 03: Output current 04: Output voltage 05: Output power 06: Bus voltage 07: +10V 08: keypad potentiometer	2	×	0701
F07.02	Y2/HO output function (when used as HO)	09: AI1 10: AI2 11: AI3 12: HI 13: Output torque 14: Ao communication given 1 15: Ao communication given 2 16: Encoder input (FR510A only)	3	×	0702
F07.03	AO1 offset	-100.0~100.0%	0.0%	△	0703
F07.04	AO1 gain	-2.000~2.000	1.000	△	0704
F07.05	AO1 filtering time	0.000~10.000s	0.000s	△	0705
F07.06	AO2 offset	-100.0~100.0%	0.00%	△	0706
F07.07	AO2 gain	-2.000~2.000	1.000	△	0707
F07.08	AO2 filtering time	0.000~10.000s	0.000s	△	0708
F07.09	HO maximum output pulse frequency	0.01~100.00kHz	50.00kHz	△	0709
F07.10	HO output filtering time	0.000~10.000s	0.010s	△	070A
F07.11	Ho output encoder pulse proportion 1 (FR510A only)	0.00~10.00	1.00	△	070B
F07.12	Ho output encoder pulse proportion 2 (FR510A only)	0.00~10.00	1.00	△	070C
Group F08 Parameters of Motor 1					
F08.00	Motor 1 type selection	0: Three phase asynchronous motors	0	×	0800
		1: PMSM (FR510A only)			
		2: Single phase asynchronous motors (Remove capacity)			
		3: Single phase asynchronous motors (No need to remove capacity)			
F08.01	Power rating of motor 1	0.1~1000.0kW	Model defined	×	0801
F08.02	Rated voltage	60~660V	Model	×	0802

FR500A&FR510A Series Vector Control Inverter

	of motor 1		defined		
F08.03	Rated current of motor 1	0.1~1500.0A	Model defined	×	0803
F08.04	Rated frequency of motor 1	20.00~Fmax	Model defined	×	0804
F08.05	Rated speed of motor 1	1~30000	Model defined	×	0805
F08.08	Stator resistance R1 of async motor 1	0.001~65.535Ω	Model defined	×	0808
F08.09	Rotor resistance R2 of async motor 1	0.001~65.535Ω	Model defined	×	0809
F08.10	Leakage inductance L1 of async motor 1	0.01~655.35mH	Model defined	×	080A
F08.11	Mutual inductance L2 of asynchronous motor 1	0.1~6553.5mH	Model defined	×	080B
F08.12	No-load current of async motor 1	0.1~1500.0A	Model defined	×	080B
F08.13	Field weakening coeff 1 of async motor 1	0.0~100.0	87%	×	080C
F08.14	Field weakening coeff 2 of async motor 1	0.0~100.0	75%	×	080E
F08.15	Field weakening coeff 3 of async motor 1	0.0~100.0	70%	×	080F
F08.16	PMSM stator resistance (FR510A only)	0.001~65.535Ω	Model defined	×	0810
F08.17	PMSM d-axis inductance (FR510A only)	0.01~655.35mH	Model defined	×	0811
F08.18	PMSM d-axis inductance (FR510A only)	0.01~655.35mH	Model defined	×	0812
F08.19	PMSM back EMF (FR510A only)	0~65535V	Model defined	×	0813
F08.20	Installation angle of encoder	0.0~359.9°	0.0°	×	0814

	(FR510A only)				
F08.21	Pole number of motor	0~1000	4	×	0815
F08.22	Find encoder origin at beginning (FR510A only)	0: Not find 1: Find	1	×	0816
F08.23	Encoder line number (FR510A only)	0~10000	1024	×	0817
F08.24	Encoder type (FR510A only)	0: ABZ encoder 1: UVW encoder 2: Rotary encoder 3: ECN1313 4: Sine-cosine encoder	0	×	0818
F08.25	AB Phase Sequence of ABZ Incremental Encoder (FR510A only)	0: Positive 1: Negative	0	×	0819
F08.26	Speed feedback PG disconnection detection time (FR510A only)	0.0: Invalid 0.1~10.0s	0.0s	×	081A
F08.27	Speed Ratio of Motor to Encoder (FR510A only)	0.001~60.000	1.000	×	081B
F08.28	Pole pairs of rotary encoder (FR510A only)	1~100	1	×	081C
F08.30	Autotuning of motor 1	0: No autotuning	0	×	081E
		1: Static autotuning of motor			
		2: Rotary autotuning of motor			
Group F09 V/f Control Parameters of Motor 1					
F09.00	V/f curve setting	00: Linear V/F	0	×	0900
		01: Multi-stage V/F			
		02: 1.2nd power V/F			
		03: 1.4nd power V/F			
		04: 1.6nd power V/F			
		05: 1.8nd power V/F			
		06: 2.0nd power V/F			
		07: V/F complete separation			
		08: V/F half separation			
		09: 1.2 power inverse curve V/F			
		10: 1.4 power inverse curve V/F			
		11: 1.6 power inverse curve V/F			
		12: 1.8 power inverse curve V/F			
13: 2.0 power inverse curve V/F					
F09.01	Torque boost	0.1%~30.0% 0.0% (fixed torque boost)	0.0%	△	0901
F09.02	Cut-off frequency of torque boost	0.00~Fmax	50.00Hz	△	0902
F09.03	Multi-point V/F	0.00~F09.05	0.00Hz	△	0903

FR500A&FR510A Series Vector Control Inverter

	frequency 1(F1)				
F09.04	Multi-point V/F voltage 1 (V1)	0.0~100.0	5.0%	△	0904
F09.05	Multi-point V/F frequency 2(F2)	F09.03~F09.05	5.00Hz	△	0905
F09.06	Multi-point V/F voltage 2 (V2)	0.0~100.0	14.0%	△	0906
F09.07	Multi-point V/F frequency 3(F3)	F09.05~F09.09	25.00Hz	△	0907
F09.08	Multi-point V/F voltage 3 (V3)	0.0~100.0	50.0%	△	0908
F09.09	Multi-point V/F frequency 4(F4)	F09.07~rated motor frequency	50.00Hz	△	0909
F09.10	Multi-point V/F voltage 4 (V4)	0.0~100.0 Ue=100.0%	100.0%	△	090A
F09.11	V/F slip compensation gain	0.0~300.0%	80.0%	△	090B
F09.12	Stator voltagedrop compensation gain	0.0~200.0%	100.0%	△	090C
F09.13	Excitation boost gain	0.0~200.0%	100.0%	△	090D
F09.14	Oscillation Suppression	0.0~300.0%	100.0%	△	090E
F09.15	Voltage source for V/F separation	0: Digital setting (F09.16)	0	×	090F
		1: keypad potentiometer			
		2: AI1			
		3: Multi-reference			
		4: Pulse setting (DI7/HI)			
		5: PID			
		6: AI2			
7: AI3					
F09.16	Voltage digital setting for V/F separation	0 V to rated motor voltage	0.0%	△	0910
F09.17	Voltage rise time of V/F separation	0.0~6000.0s It indicates the time for the voltage rising from 0 V to rated Motor voltage.	0.1s	△	0911
F09.18	Set the IQ filter time below 0.5Hz in VVF mode	F09.19~3000ms	500ms	×	0912
F09.19	Set the IQ filter time above 2Hz in VVF mode	1ms~F09.18	100ms	×	0913
F09.20	Torque revision when run forward	0.0~5.0%	0.0%	△	0914
F09.21	Torque revision when run	0.0~5.0%	1.0%	△	0915

	reverse				
F09.22	PMSM acceleration current compensation setting (FR510A only)	0.0~200.0%	0.0%	△	0916
F09.23	PMSM compensation time decreased after acceleration (FR510A only)	0.0~100.0s	2.0s	△	0917
F09.24	PMSM ID current value will be maintained after accelerating. (FR510A only)	0.0~200.0%	0.0%	△	0918
Group F10 Vector Control Parameters of Motor 1					
F10.00	Speed/torque control	0: speed control	0	×	0A00
		1: torque control			
F10.01	ASR low-speed proportional gain Kp1	0.0~100.0	15.0	△	0A01
F10.02	ASR low-speed integration time Ti1	0.001~30.000s	0.100s	△	0A02
F10.03	ASR switching frequency 1	0.00~F10.06	5.00Hz	△	0A03
F10.04	ASR high-speed proportional gain Kp2	1~100.0	10.0	△	0A04
F10.05	ASR high-speed integration time Ti2	0.001~30.000s	0.500s	△	0A05
F10.06	ASR switching frequency 2	F10.03~Fmax	10.00Hz	△	0A06
F10.07	ASR input filtering time	0.0~500.0ms	3.0ms	△	0A07
F10.08	ASR output filtering time	0.0~500.0ms	0.0ms	△	0A08
F10.09	Vector control slip gain	50~200%	100%	△	0A09
F10.10	Digital setting of torque upper limit in speed control mode	80.0~200.0%	165.0%	×	0A0A
F10.11	Excitation adjustment proportional gain Kp1	0.00~10.00	0.50	△	0A0B
F10.12	Excitation	0.0~3000.0ms	10.0ms	△	0A0C

FR500A&FR510A Series Vector Control Inverter

	adjustment integral gain Ti1				
F10.13	Torque adjustment proportional gain Kp2	0.00~10.00	0.50	△	0A0D
F10.14	Torque adjustment integral gain Ti2	0.0~3000.0ms	10.0ms	△	0A0E
F10.15	Excitation gain coefficient	50.0~200%	100%	△	0A0F
F10.16	Torque setting source under torque control	0: Set by F10.17	0	×	0A10
		1: Keypad potentiometer			
		2: AI1			
		3: AI2			
		4: AI3			
		5: Pulse setting (DI7/HI)			
	6: Communication setting				
F10.17	Digital setting of torque	-200.0~200.0%	50.0%	△	0A11
F10.18	Forward speed limited value under torque control	0.00~Fmax	50.00Hz	△	0A12
F10.19	Reverse speed limited value under torque control	0.00~ Fmax	50.00Hz	△	0A13
F10.20	Set torque accel time	0.0~6000.0s	0.0s	△	0A14
F10.21	Set torque decel time	0.0~6000.0s	0.0s	△	0A15
F10.22	Static friction torque compensation	0.0~100.0%	5.00%	△	0A16
F10.23	Static friction frequency range	0.00~20.00Hz	1.00Hz	△	0A17
F10.24	Static Frequency of Open-Loop Torque	1.00~10.00Hz	1.00Hz	△	0A18
F10.25	SVC optimization method	0: Optimization method 1 1: Optimization method 2 2: Optimization method 3	1	×	0A19
F10.26	Max Frequency source under torque control	0: Set by F10.18 & F10.19	0	×	0A1A
		1: Keypad potentiometer			
		2: AI1			
		3: AI2			
		4: AI3			
	5: Pulse setting (DI7/HI)				
F10.27	PMSM Start Excitation Current (FR510A only)	0.0~150.0%	50.0%	×	0A1B

F10.28	PMSM Flux weakening control (FR510A only)	0: Invalid 1: Valid	1	×	0A1C
F10.29	PMSM Flux weakening Voltage (FR510A only)	70.0~100.0%	95.0%	△	0A1D
F10.30	PMSM Flux weakening gain(Kp) (FR510A only)	0.0~500.0%	30.0%	△	0A1E
F10.31	PMSM Flux weakening integral(Ti) (FR510A only)	0.00~60.00s	0.5s	△	0A1F
F10.32	PMSM Flux weakening limit (FR510A only)	0.0~200.0%	100.0%	△	0A20
F10.33	PMSM excitation current frequency high point (FR510A only)	F10.34~600.00Hz	15.00Hz	△	0A21
F10.34	PMSM excitation current frequency low point (FR510A only)	0.0~F10.33	10.00Hz	△	0A22
F10.35	PMSM excitation current conversion delay (FR510A only)	0.0~10.0s	1.0s	△	0A23
F10.36	PMSM speed estimation Kp (FR510A only)	0.00~10.00	2.00	△	0A24
F10.37	PMSM speed estimation Ti (FR510A only)	0.1~1000.0ms	20.0ms	△	0A25
Group F11 Protection Parameters					
F11.00	Current limit control	0: Current limit disabled	2	×	0B00
		1: Current limit mode 1			
		2: Current limit mode 2			
F11.01	Current limit	100.0~200.0%	150.0%	×	0B01
F11.02	Frequency decreasing time(limit current in constant speed operation)	0.0~6000.0s	5.0s	△	0B02
F11.03	Current limit mode 2 proportion gain	0.1~100.0%	3.0%	△	0B03
F11.04	Current limit	0.00~10.00s	10.00s	△	0B04

FR500A&FR510A Series Vector Control Inverter

	mode 2 integral time				
F11.05	Overvoltage Stall Control	0: Overvoltage stall disabled	2	×	0B05
		1: Overvoltage stall mode 1			
		2: Overvoltage stall mode 2			
F11.06	Overvoltage stall voltage	600~800V	730V	×	0B06
F11.07	Overvoltage Stall Mode 2 Proportion Gain	0.0~100.0%	50.0%	△	0B07
F11.08	Overvoltage stall mode 2 frequency limit	0.00~50.00Hz	5.00Hz	×	0B08
F11.10	Protection action 1	Unit's place: Bus undervoltage 0: Fault reported and coast to stop 1: Stop according to the stop mode 2: Fault reported but continue to run 3: Fault protection disabled	03330	×	0B0A
		Ten's place: Power input phase Loss (Err09) (Same as unit's place)			
		Hundred's place: Power output phase loss(Err10) (Same as unit's place)			
		Thousand's place: Motor overload (Err11)(Same as unit's place)			
		Ten thousand's place: Inverter overload(Err12) (Same as unit's place)			
F11.11	Protection action 2	External equipment fault (Err13) 0: Fault reported and coast to stop 1: Stop according to the stop mode 2: Fault reported but continue to run	00000	×	0B0B
		Ten's place: EEPROM read/write fault (Err15) (Same as unit's place)			
		Hundred's place: Communication overtime error (Err18) (Same as unit's place)			
		Thousand's place: PID feedback loss (Err19) (Same as unit's place)			
		Ten thousand's place: Continuous running time reached (Err20) (Same as unit's place)			

F11.12	Protection action 3	Unit's place: Module temperature detection disconnection (Err24) 0: Fault reported and coast to stop 1: Stop according to the stop mode 2: Fault reported but continue to run 3: Fault protection disabled	00030	×	0B0C
		Ten's place: Load becoming 0 (Err25) (Same as unit's place)			
F11.14	Frequency selection for continuing to run upon fault	0: Current running frequency	1	×	0B0D
		1: Set frequency			
		2: Frequency upper limit			
		3: Frequency lower limit			
4: Backup frequency upon abnormality					
F11.15	Backup frequency upon abnormality	0.00~Fmax	0.00Hz	×	0B0E
F11.17	Motor overload protection time	30.0~300.0s	60.0s	×	0B11
F11.18	Overload alarm	Unit's place: detection option: 0: Always detect 1: Detect at constant speed only	00010	×	0B12
		Ten's place: compared object 0: Rated current of motor 1: Rated current of drive			
		Hundred's place: Fault reported 0: No fault reported 1: Fault reported			
		Thousand's place: whether to decelerate or not when overload alarm 0: No deceleration 1: Deceleration			
Ten thousand's place: given mode for overload threshold 0: F11.19 set 1: F11.19*VP 2: F11.19*AI1 3: F11.19*AI2 4: F11.19*AI3					
F11.19	Overload alarm threshold	20.0~200.0%	130.0%	×	0B13
F11.20	Overload alarm activated time that exceeding threshold	0.1~60.0s	5.0s	×	0B14
F11.21	Inverter overheat warning threshold	50~overheat Temperature	Model defined	×	0B15
F11.22	Detection level of load loss	5.0~100.0%	20.0%	×	0B16
F11.23	Detection time	0.1~60.0s	5.0s	×	0B17

FR500A&FR510A Series Vector Control Inverter

	of load loss				
F11.24	Action selection at instantaneous power failure	0: Disabled	0	×	0B18
		1: Deceleration			
		2: Bus voltage constant control			
F11.25	Decel time at instantaneous power failure	0.0~6000.0s	5.0s	△	0B19
F11.26	Rapid current limit	0: Disabled	2	×	0B1A
		1: Rapid current limiting mode 1			
		2: Rapid current limiting mode 2			
F11.27	Times of automatic trip(fault) reset	0~20	0	×	0B1B
F11.28	Interval of automatic trip(fault) reset	0.1~100.0s	1.0s	×	0B1C
F11.29	DO action during fault auto reset	0: Not act	0	×	0B1D
		1: Act			
F11.30	Instantaneous power off bus voltage	60.0%~Recovery voltage	80.0%	△	0B1E
F11.31	Instantaneous power off recovery voltage	Power off voltage~100.0%	85.0%	△	0B1F
F11.32	Instantaneous power off voltage detection time	0.01~10.00s	0.10s	△	0B20
F11.33	Instantaneous power off Kp	0.1~100.0%	40.0%	△	0B21
F11.34	Instantaneous power off integration time Ti	0.00~10.00s (0.00: Integration invalid)	0.10s	△	0B22
F11.35	Motor temperature sensor type	0:None 1:PT100 2:PT1000 3:KTY84	0	×	0B23
F11.36	Zero drift value of motor temperature sensor	-100~100℃	0	△	0B24
F11.37	Reserved				0B25
F11.38	Motor temperature warning action threshold	0~200℃	90℃	△	0B26
F11.39	Motor temperature protection action threshold	0~200℃	110℃	△	0B27

F11.40	Action selection of Excessive Speed and Excessive Speed Deviation (FR510A only)	Unit's place: Overspeed Action Selection 0:Report error and coast to stop 1:Warning and ramp to stop 2: Alarm and continue run with failure frequency 3:No protection	00	×	0B28
		Ten's place: Selection of Excessive Speed Deviation 0:Report error and coast to stop 1:Warning and ramp to stop 2: Alarm and continue run with failure frequency 3:No protection			
F11.41	Overspeed detection value (FR510A only)	0.0~150.0%	120.0%	×	0B29
F11.42	Overspeed detection time (FR510A only)	0.0~60.0s	1.0s	×	0B2A
F11.43	Detection value of excessive velocity deviation (FR510A only)	0.0~50.0%	20.0%	×	0B2B
F11.44	Detection time of excessive velocity deviation (FR510A only)	0.0~60.0s	5.0s	×	0B2C
Group F12: Multi-Reference and Simple PLC Function					
F12.00	Reference 0	-100.0~100.0%	0.0%	△	0C00
F12.01	Reference 1	-100.0~100.0%	0.0%	△	0C01
F12.02	Reference 2	-100.0~100.0%	0.0%	△	0C02
F12.03	Reference 3	-100.0~100.0%	0.0%	△	0C03
F12.04	Reference 4	-100.0~100.0%	0.0%	△	0C04
F12.05	Reference 5	-100.0~100.0%	0.0%	△	0C05
F12.06	Reference 6	-100.0~100.0%	0.0%	△	0C06
F12.07	Reference 7	-100.0~100.0%	0.0%	△	0C07
F12.08	Reference 8	-100.0~100.0%	0.0%	△	0C08
F12.09	Reference 9	-100.0~100.0%	0.0%	△	0C09
F12.10	Reference 10	-100.0~100.0%	0.0%	△	0C0A
F12.11	Reference 11	-100.0~100.0%	0.0%	△	0C0B
F12.12	Reference 12	-100.0~100.0%	0.0%	△	0C0C
F12.13	Reference 13	-100.0~100.0%	0.0%	△	0C0D
F12.14	Reference 14	-100.0~100.0%	0.0%	△	0C0E
F12.15	Reference 15	-100.0~100.0%	0.0%	△	0C0F
F12.16	Reference 0 source	0: Digital setting (F12.00)	0	×	0C10
		1: keypad potentiometer			
		2: AI1			
		3: Process PID output			
		4: X7/HI pulse input			
		5: AI2			
6: AI3					

FR500A&FR510A Series Vector Control Inverter

F12.17	Running mode of simple PLC	Unit's place: PLC running mode 0: Stop after a single cycle 1: Continue to run with the last frequency after a single cycle 2: Repeat cycles	00000	×	0C11
		Ten's place: started mode 0: Continue to run from the step of stop (or fault) 1: Run from the first step "multi-step frequency 0" 2: Run from the eighth step "multi-step frequency 8" 3: Run from the fifteenth step "multi-step frequency 15"			
		Hundreds place: power loss memory 0: Memory disabled on power loss 1: Memory enabled on power loss			
		Thousands place: unit of simple PLC running time 0: Second (s) 1: Minute (min)			
F12.18	Running time of step 0	0.0~6000.0s(h)	0.0s(h)	△	0C12
F12.19	Running time of step 1	0.0~6000.0s(h)	0.0s(h)	△	0C13
F12.20	Running time of step 2	0.0~6000.0s(h)	0.0s(h)	△	0C14
F12.21	Running time of step 3	0.0~6000.0s(h)	0.0s(h)	△	0C15
F12.22	Running time of step 4	0.0~6000.0s(h)	0.0s(h)	△	0C16
F12.23	Running time of step 5	0.0~6000.0s(h)	0.0s(h)	△	0C17
F12.24	Running time of step 6	0.0~6000.0s(h)	0.0s(h)	△	0C18
F12.25	Running time of step 7	0.0~6000.0s(h)	0.0s(h)	△	0C19
F12.26	Running time of step 8	0.0~6000.0s(h)	0.0s(h)	△	0C1A
F12.27	Running time of step 9	0.0~6000.0s(h)	0.0s(h)	△	0C1B
F12.28	Running time of step 10	0.0~6000.0s(h)	0.0s(h)	△	0C1C
F12.29	Running time of step 11	0.0~6000.0s(h)	0.0s(h)	△	0C1D
F12.30	Running time of step 12	0.0~6000.0s(h)	0.0s(h)	△	0C1E
F12.31	Running time of step 13	0.0~6000.0s(h)	0.0s(h)	△	0C1F
F12.32	Running time of step 14	0.0~6000.0s(h)	0.0s(h)	△	0C20
F12.33	Running time of step 15	0.0~6000.0s(h)	0.0s(h)	△	0C21
F12.34	Acceleration/de	0~3	0	△	0C22

	celeration time of simple PLC reference 0				
F12.35	Acceleration/deceleration time of simple PLC reference 1	0~3	0	△	0C23
F12.36	Acceleration/deceleration time of simple PLC reference 2	0~3	0	△	0C24
F12.37	Acceleration/deceleration time of simple PLC reference 3	0~3	0	△	0C25
F12.38	Acceleration/deceleration time of simple PLC reference 4	0~3	0	△	0C26
F12.39	Acceleration/deceleration time of simple PLC reference 5	0~3	0	△	0C27
F12.40	Acceleration/deceleration time of simple PLC reference 6	0~3	0	△	0C28
F12.41	Acceleration/deceleration time of simple PLC reference 7	0~3	0	△	0C29
F12.42	Acceleration/deceleration time of simple PLC reference 8	0~3	0	△	0C2A
F12.43	Acceleration/deceleration time of simple PLC reference 9	0~3	0	△	0C2B
F12.44	Acceleration/deceleration time of simple PLC reference 10	0~3	0	△	0C2C
F12.45	Acceleration/deceleration time of simple PLC reference 11	0~3	0	△	0C2D
F12.46	Acceleration/deceleration time of simple PLC reference 12	0~3	0	△	0C2E
F12.47	Acceleration/deceleration time of simple PLC reference 13	0~3	0	△	0C2F
F12.48	Acceleration/deceleration time	0~3	0	△	0C30

FR500A&FR510A Series Vector Control Inverter

	of simple PLC reference 14				
F12.49	Acceleration/deceleration time of simple PLC reference 15	0~3	0	△	0C31
F12.50	UP/DOWN function selection of Multi-reference	Unit's place: Action selection when power off 0:Zero clearing when power off 1:Hold when power off	00	×	0C32
		Ten's place: select if it can be reduced to negative 0:Disable 1:Enable			
F12.51	UP/DOWN speed of Multi-reference	0.0~100.0% (0.0%Invalid)	0.0%	△	0C33
Group F13 Process PID					
F13.00	PID setting	0: F13.01 digital setting	0	×	0D00
		1: keypad potentiometer			
		2: AI1			
		3: Communication			
		4: Multi-Reference			
		5: DI7/HI pulse input			
		6: AI2			
F13.01	PID digital setting	0.0~100.0%	50.0%	△	0D01
F13.02	PID feedback	0: AI1	0	×	0D02
		1: AI2			
		2: Communication			
		3: AI1+AI2			
		4: AI1-AI2			
		5: Max{AI1, AI2}			
		6: Min{AI1, AI2}			
		7: DI7/HI pulse input			
F13.03	PID setting feedback range	0.0~6000.0	100.0	△	0D03
F13.04	PID action direction	0: Forward action	0	×	0D04
		1: Reverse action			
F13.05	Filtering time of PID setting	0.000~10.000s	0.000s	△	0D05
F13.06	Filtering time of PID feedback	0.000~10.000s	0.000s	△	0D06
F13.07	Filtering time of PID output	0.000~10.000s	0.000s	△	0D07
F13.08	Proportional gain Kp1	0.0~100.0	1.0	△	0D08
F13.09	Integration time Ti1	0.01~10.00s	0.10s	△	0D09
F13.10	Differential time Td1	0.000~10.000s	0.000s	△	0D0A
F13.11	Proportional	0.0~100.0	1.0	△	0D0B

	gain Kp2				
F13.12	Integration time Ti2	0.01~10.00s	0.10s	△	0D0C
F13.13	Differential time Td2	0.000~10.000s	0.000s	△	0D0D
F13.14	PID parameter switch	0: No switch, determined by parameters Kp1, Ti1 and Td1	0	×	0D0E
		1: Auto switch on the basis of input offset			
		2: Switched by terminal			
F13.15	PID parameter switchover deviation 1	0.0~100.0%	20.0%	×	0D0F
F13.16	PID parameter switchover deviation 2	0.0~100.0%	80.0%	×	0D10
F13.17	PID offset limit	0.0~100.0%	0.0%	×	0D011
F13.18	PID integral property	Unit's place (Whether to stop integral operation when the output reaches the limit) 0: Continue integral operation 1: Stop integral operation	00	×	0D12
		Ten's place (Integral separated) 0: Invalid 1: Valid			
F13.19	PID differential limit	0.0~100.0%	0.5%	×	0D13
F13.20	PID initial value	0.0~100.0%	0.0%	×	0D14
F13.21	Holding time of PID initial value	0.0~6000.0s	0.0s	×	0D15
F13.22	PID output frequency upper limit	PID output frequency lower limit~100.0% (100.0% corresponds to maximum frequency)	100.0%	×	0D16
F13.23	PID output frequency lower limit	-100.0%~PID output frequency lower limit	0.0%	×	0D17
F13.24	Low value of PID feedback loss	0.1~100.0% 0.0%: Not judging feedback loss	0.0%	×	0D18
F13.25	Detection time for low value of PID feedback loss	0.0~30.0s	1.0s	×	0D19
F13.26	PID operation selection	Unit's place: PID operation selection when stop 0:Do not operate when stop 1:Operate when stop	00000	×	0D1A
		Ten's place: output is limited by output frequency 0:No limited 1:limited			
		Hundred's place: UP/DOWN digital given of PID 0:Zero clearing when power off 1:Hold when power off			
		Thousand's place: PID feedback			

FR500A&FR510A Series Vector Control Inverter

		loss detection when stop 0:Not detect when stop 1:detect when stop			
		Then thousand's place: action for PID feedback loss 0:Report fault 1:Ramp to stop			
F13.27	UP/DWON speed of PID digital given	0.0~100.0% (0.0% Invalid)	0.0%	△	
F13.28	High value of PID feedback loss	0.1~100.0% 0.0%: Not judging feedback loss	100.0%	×	0D1B
F13.29	Detection time for high value of PID feedback loss	0.0~30.0s	1.0s	×	0D1C
F13.30	PID upper limit source	0:F13.22 1:F13.22*VP 2:F13.22*AI1 3:F13.22*AI2 4:F13.22*HI 5:F13.22*AI3	0	×	0D1D
F13.31	PID lower limit source	0:F13.23 1:F13.23*VP 2:F13.23*AI1 3:F13.23*AI2 4:F13.23*HI 5:F13.23*AI3	0	×	0D1E
Group F14: Swing Frequency, Fixed Length , Wakeup and Count					
F14.00	Swing frequency setting mode	0: Relative to the setting frequency	0	×	0E00
		1: Relative to the maximum frequency			
F14.01	Swing frequency amplitude	0.0~100.0%	0.0%	△	0E01
F14.02	Jump frequency amplitude	0.0~50.0%	0.0%	△	0E02
F14.03	Rising Time of Swing frequency	0.0~6000.0s	5.0s	△	0E03
F14.04	Dropping Time of Swing frequency	0.0~6000.0s	5.0s	△	0E04
F14.05	Set length	0m~65535m	1000m	×	0E05
F14.06	Number of pulses per meter	0.1~6553.5	100.0	×	0E06
F14.07	Command when the length attained	Unit's place: stop when the length reaches 0: Not stop 1: Stop	00	×	0E07
		Ten's place: length calculation method 0: pulse by pulse 1: Reference maximum frequency			

		2: Refer to AI1 channel 3: Refer to AI2 channel 4: Refer to AI3 channel			
F14.08	Set count value	1~65535	1000	×	0E08
F14.09	Designated count value	1~65535	1000	×	0E09
F14.10	Wakeup frequency	Dormant frequency (F14.12)~ Fmax	0.00Hz	△	0E0A
F14.11	Wakeup delay time	0.0~6000.0s	0.0s	△	0E0B
F14.12	Dormant frequency	0.00~Wakeup frequency	0.00Hz	△	0E0C
F14.13	Dormant delay time	0.0~6000.0s	0.0s	△	0E0D
F14.14	Wake up mode selection	0: Frequency 1: Pressure	0	×	0E0E
F14.15	Dormancy mode selection	0: Frequency 1: Pressure	0	×	0E0F
F14.16	Voltage feedback source	Unit's place: pressure feedback 0: AI1 1: AI2 2: DI7/HI pulse input 3: AI3 Ten's place: pressure dormancy mode 0:Positive direction, dormancy on big pressure and wakeup on small pressure 1:Negative direction, dormancy on small pressure and wakeup on big pressure	0	×	0E10
F14.17	Wake up pressure	0.0%~Dormancy pressure	10.0%	△	0E11
F14.18	Dormancy pressure	Wake up pressure~100.0%	50.0%	△	0E12
Group F15: Communication Parameters					
F15.00	Baud rate	0: 4800bps 1: 9600bps 2: 19200bps 3: 38400bps 4: 57600bps 5: 115200bps	1	×	0F00
F15.01	Data format	No check, data format (1-8-N-2) for RTU 1: Even parity check, data format (1-8-E-1) for RTU 2: Odd Parity check, data format (1-8-O-1) for RTU 3: No check, data format(1-8-N-1) for RTU	0	×	0F01
F15.02	Local address	1~247 0: Broadcast address	1	×	0F02
F15.03	Communication timeout	0.0~60.0s	0.0s	×	0F03
F15.04	Response time delay	0~200ms	1ms	×	0F04
F15.05	Master-slave Communication	0:The inverter is the slave 1:The inverter is the master	0	×	0F05

FR500A&FR510A Series Vector Control Inverter

	Mode				
F15.06	The Master Communication Sending Data	0: Set frequency	0	×	0F06
		1: Current running frequency			
F15.07	Message return when communication error	0: No return	1		0F07
		1: Return			
F15.08	U group return value	0: Positive and negative	0	△	0F08
		1: Absolute value			
Group F16 Keys and Display of Keypad Parameters					
F16.00	MF.K key setting	0: No function	1	×	1000
		1: Jog			
		2: Forward/reverse switchover			
		3: Run command sources shifted			
		4: Jog reverse			
F16.01	Keyboard operation display	Unit's digit: Function selection of STOP/RESET key 0: stop function of STOP/RESET key is valid only in keyboard operation mode 1: Stop function of STOP/RES key is valid in any operation mode	001	×	1001
		Ten's digit: Speed display (U00.05) 0: According to the actual speed 1: Multiply frequency by speed coefficient(F16.11)			
		Hundred's digit: Decimal places 0: No decimal places 1: One decimal places 2: Two decimal places 3: Three decimal places			
F16.02	Keys locked option	0: Not locked	0	×	1002
		1: Full locked			
		2: Keys locked other than RUN, STOP/RST			
		3: Keys locked other than STOP/RST			
		4: Keys locked other than >>			
F16.03	LED displayed parameters setting 1 on running status	0~99(correspond U00.00~U00.99)	0	△	1003
F16.04	LED displayed parameters setting 2 on running status	0~99(correspond U00.00~U00.99)	6	△	1004
F16.05	LED displayed parameters setting 3 on running status	0~99(correspond U00.00~U00.99)	3	△	1005
F16.06	LED displayed parameters setting 4 on running status	0~99(correspond U00.00~U00.99)	2	△	1006
F16.07	LED displayed parameters	0~99(correspond U00.00~	1	△	1007

	setting 1 on stop status	U00.99)			
F16.08	LED displayed parameters setting 2 on stop status	0~99(correspond U00.00~U00.99)	6	△	1008
F16.09	LED displayed parameters setting 3 on stop status	0~99(correspond U00.00~U00.99)	15	△	1009
F16.10	LED displayed parameters setting 4 on stop status	0~99(correspond U00.00~U00.99)	16	△	100A
F16.11	Speed display coefficient	0.00~100.00	1.00	△	100B
F16.12	Power display coefficient	0.0~300.0%	100.0%	△	100C
F16.13	The enable difference range of U00.00 and U00.01	0.00Hz~5.00Hz	0.10Hz	△	100D
Group F17 User-defined Display Parameters					
F17.00	User-defined Display Parameter 0	00.00~49.99	00.03	△	1100
F17.01	User-defined Display Parameter 1	00.00~49.99	01.01	△	1101
F17.02	User-defined Display Parameter 2	00.00~49.99	01.02	△	1102
F17.03	User-defined Display Parameter 3	00.00~49.99	01.08	△	1103
F17.04	User-defined Display Parameter 4	00.00~49.99	01.09	△	1104
F17.05	User-defined Display Parameter 5	00.00~49.99	02.00	△	1105
F17.06	User-defined Display Parameter 6	00.00~49.99	02.01	△	1106
F17.07	User-defined Display Parameter 7	00.00~49.99	02.12	△	1107
F17.08	User-defined Display Parameter 8	00.00~49.99	03.00	△	1108
F17.09	User-defined Display Parameter 9	00.00~49.99	03.01	△	1109
F17.10	User-defined Display Parameter 10	00.00~49.99	04.00	△	110A

FR500A&FR510A Series Vector Control Inverter

F17.11	User-defined Display Parameter 11	00.00~49.99	04.01	△	110B
F17.12	User-defined Display Parameter 12	00.00~49.99	04.02	△	110C
F17.13	User-defined Display Parameter 13	00.00~49.99	04.03	△	110D
F17.14	User-defined Display Parameter 14	00.00~49.99	05.02	△	110E
F17.15	User-defined Display Parameter 15	00.00~49.99	08.01	△	110F
F17.16	User-defined Display Parameter 16	00.00~49.99	08.02	△	1110
F17.17	User-defined Display Parameter 17	00.00~49.99	08.03	△	1111
F17.18	User-defined Display Parameter 18	00.00~49.99	08.04	△	1112
F17.19	User-defined Display Parameter 19	00.00~49.99	08.05	△	1113
F17.20	User-defined Display Parameter 20	00.00~49.99	08.30	△	1114
F17.21	User-defined Display Parameter 21	00.00~49.99	11.10	△	1115
F17.22	User-defined Display Parameter 22	00.00~49.99	13.00	△	1116
F17.23	User-defined Display Parameter 23	00.00~49.99	13.01	△	1117
F17.24	User-defined Display Parameter 24	00.00~49.99	13.02	△	1118
F17.25	User-defined Display Parameter 25	00.00~49.99	13.08	△	1119
F17.26	User-defined Display Parameter 26	00.00~49.99	13.09	△	111A
F17.27	User-defined Display Parameter 27	00.00~49.99	00.00	△	111B
F17.28	User-defined Display Parameter 28	00.00~49.99	00.00	△	111C
F17.29	User-defined Display Parameter 29	00.00~49.99	00.00	△	111D
Group F18 Parameters of Motor 2					

F18.00	Motor 2 type selection	0: Three phase asynchronous motors	0	×	1200
		1: Sync motor(PMSM)			
		2: Single phase asynchronous motors (Remove capacity)			
		3: Single phase asynchronous motors (No need to remove capacity)			
F18.01	Power rating of motor 2	0.1~1000.0kW	Model defined	×	1201
F18.02	Rated voltage of motor 2	60~660V	Model defined	×	1202
F18.03	Rated current of motor 2	0.1~1500.0A	Model defined	×	1203
F18.04	Rated frequency of motor 2	20.00~Fmax	Model defined	×	1204
F18.05	Rated speed of motor 2	1~30000	Model defined	×	1205
F18.08	Stator resistance R1 of async motor 2	0.001~65.535Ω	Model defined	×	1208
F18.09	Rotor resistance R2 of async motor 2	0.001~65.535Ω	Model defined	×	1209
F18.10	Leakage inductance L1 of async motor 2	0.01~655.35mH	Model defined	×	120A
F18.11	Mutual inductance L2 of asynchronous motor 2	0.1~6553.5mH	Model defined	×	120B
F18.12	No-load current of async motor 2	0.1~1500.0A	Model defined	×	120C
F18.13	Field weakening coeff 1 of async motor 2	0.0~100.0	87%	×	120D
F18.14	Field weakening coeff 2 of async motor 2	0.0~100.0	75%	×	120E
F18.15	Field weakening coeff 3 of async motor 2	0.0~100.0	70%	×	120F
F18.16	PMSM Stator resistance (FR510A only)	0.001~65.535Ω	Model defined	×	1210
F18.17	PMSM D-axis	0.01~655.35mH	Model	×	1211

FR500A&FR510A Series Vector Control Inverter

	inductance (FR510A only)		defined		
F18.18	PMSM Q-axis inductance (FR510A only)	0.01~655.35mH	Model defined	×	1212
F18.19	PMSM back EMF (FR510A only)	0~65535V	Model defined	×	1213
F18.20	Installation angle of encoder (FR510A only)	0.0~359.9°	0.0°	×	1214
F18.21	Pole number of motor	0~1000	4	×	1215
F18.22	Find encoder origin at beginning (FR510A only)	0: Not find 1: Find	1	×	1216
F18.23	Encoder line number (FR510A only)	0~10000	1024	×	1217
F18.24	Encoder type (FR510A only)	0: ABZ encoder 1: UVW encoder 2: Rotary encoder 3: ECN1313 4: Sine-cosine encoder	0	×	1218
F18.25	AB Phase Sequence of ABZ Incremental Encoder (FR510A only)	0: Positive 1: Negative	0	×	1219
F18.26	Speed feedback PG disconnection detection time (FR510A only)	0.0: Invalid 0.1~10.0s	0.0s	×	121A
F18.27	Speed Ratio of Motor to Encoder (FR510A only)	0.001~60.000	1.000	×	121B
F18.28	Pole pairs of rotary encoder (FR510A only)	1~100	1	×	121C
F18.30	Autotuning of motor 2	0: No autotuning	0	×	121E
		1: Static autotuning of motor			
		2: Rotary autotuning of motor			
Group F19 V/f Control Parameters of Motor 2					
F19.00	V/f curve setting	00: Linear V/F	0	×	1300
		01: Multi-stage V/F			
		02: 1.2nd power V/F			
		03: 1.4nd power V/F			
		04: 1.6nd power V/F			
		05: 1.8nd power V/F			
		06: 2.0nd power V/F			
		07: V/F complete separation			
08: V/F half separation					

		09: 1.2 power inverse curve V/F			
		10: 1.4 power inverse curve V/F			
		11: 1.6 power inverse curve V/F			
		12: 1.8 power inverse curve V/F			
		13: 2.0 power inverse curve V/F			
F19.01	Torque boost	0.1%~30.0% 0.0% (fixed torque boost)	0.0%	△	1301
F19.02	Cut-off frequency of torque boost	0.00~Fmax	50.00Hz	△	1302
F19.03	Multi-point V/F frequency 1(F1)	0.00~F19.05	0.00Hz	△	1303
F19.04	Multi-point V/F voltage 1 (V1)	0.0~100.0	5.0%	△	1304
F19.05	Multi-point V/F frequency 2(F2)	F19.03~F19.05	5.00Hz	△	1305
F19.06	Multi-point V/F voltage 2 (V2)	0.0~100.0	14.0%	△	1306
F19.07	Multi-point V/F frequency 3(F3)	F19.05~F19.09	25.00Hz	△	1307
F19.08	Multi-point V/F voltage 3 (V3)	0.0~100.0	50.0%	△	1308
F19.09	Multi-point V/F frequency 4(F4)	F19.07~rated motor frequency	50.00Hz	△	1309
F19.10	Multi-point V/F voltage 4 (V4)	0.0~100.0 Ue=100.0%	100.0%	△	130A
F19.11	V/F slip compensation gain	0.0~300.0%	80.0%	△	130B
F19.12	Stator voltagedrop compensation gain	0.0~200.0%	100.0%	△	130C
F19.13	Excitation boost gain	0.0~200.0%	100.0%	△	130D
F19.14	Oscillation Suppression	0.0~300.0%	100.0%	△	130E
F19.15	Voltage source for V/F separation	0: Digital setting (F19.16) 1: keypad potentiometer 2: AI1 3: Multi-reference 4: Pulse setting (DI7/HI) 5: PID 6: AI2 7: AI3	0	×	130F
F19.16	Voltage digital setting for V/F separation	0 V to rated motor voltage	0.0%	△	1310
F19.17	Voltage rise time of V/F separation	0.0~6000.0s It indicates the time for the voltage rising from 0 V to rated Motor voltage.	0.1s	△	1311
F19.18	Set the IQ filter	F19.19~3000ms	500ms	×	1312

FR500A&FR510A Series Vector Control Inverter

	time below 0.5Hz in VVF mode				
F19.19	Set the IQ filter time above 2Hz in VVF mode	1ms~F19.18	100ms	×	1313
F19.20	Torque revision when run forward	0.0~5.0%	0.0%	△	1314
F19.21	Torque revision when run reverse	0.0~5.0%	1.0%	△	1315
F19.22	PMSM acceleration current compensation setting (FR510A only)	0.0~200.0%	0.0%	△	1316
F19.23	PMSM compensation time decreased after acceleration (FR510A only)	0.0~100.0s	2.0s	△	1317
F19.24	PMSM ID current value will be maintained after accelerating. (FR510A only)	0.0~200.0%	0.0%	△	1318
Group F20 Vector Control Parameters of Motor 2					
F20.00	Speed/torque control	0: speed control	0	×	1400
		1: torque control			
F20.01	ASR low-speed proportional gain Kp1	0.0~100.0	15.0	△	1401
F20.02	ASR low-speed integration time Ti1	0.001~30.000s	0.100s	△	1402
F20.03	ASR switching frequency 1	0.00~F20.06	5.00Hz	△	1403
F20.04	ASR high-speed proportional gain Kp2	1~100.0	10.0	△	1404
F20.05	ASR high-speed integration time Ti2	0.001~30.000s	0.500s	△	1405
F20.06	ASR switching frequency 2	F20.03~Fmax	10.00Hz	△	1406
F20.07	ASR input filtering time	0.0~500.0ms	3.0ms	△	1407
F20.08	ASR output filtering time	0.0~500.0ms	0.0ms	△	1408
F20.09	Vector control slip gain	50~200%	100%	△	1409

F20.10	Digital setting of torque upper limit in speed control mode	80.0~200.0%	165.0%	×	140A
F20.11	Excitation adjustment proportional gain Kp1	0.00~10.00	0.50	△	140B
F20.12	Excitation adjustment integral gain Ti1	0.0~3000.0ms	10.0ms	△	140C
F20.13	Torque adjustment proportional gain Kp2	0.00~10.00	0.50	△	140D
F20.14	Torque adjustment integral gain Ti2	0.0~3000.0ms	10.0ms	△	140E
F20.15	Excitation gain coefficient	50.0~200%	100%	△	140F
F20.16	Torque setting source under torque control	0: Set by F20.17	0	×	1410
		1: Keypad potentiometer			
		2: AI1			
		3: AI2			
		4: AI3			
		5: Pulse setting (DI7/HI)			
6: Communication setting					
F20.17	Digital setting of torque	-200.0~200.0%	50.0%	△	1411
F20.18	Forward speed limited value under torque control	0.00~Fmax	50.00Hz	△	1412
F20.19	Reverse speed limited value under torque control	0.00~ Fmax	50.00Hz	△	1413
F20.20	Set torque accel time	0.0~6000.0s	0.0s	△	1414
F20.21	Set torque decel time	0.0~6000.0s	0.0s	△	1415
F20.22	Static friction torque compensation	0.0~100.0%	5.00%	△	1416
F20.23	Static friction frequency range	0.00~20.00Hz	1.00Hz	△	1417
F20.24	Static Frequency of Open-Loop Torque	1.00~10.00Hz	1.00Hz	△	1418
F20.25	SVC optimization method	0: Optimization method 1 1: Optimization method 2 2: Optimization method 3	1	×	1419
F20.26	Max Frequency	0: Set by F20.18 & F20.19	0	×	141A

FR500A&FR510A Series Vector Control Inverter

	source under torque control	1: Keypad potentiometer 2: AI1 3: AI2 4: AI3 5: Pulse setting (DI7/HI)			
F20.27	PMSM Start Excitation Current (FR510A only)	0.0~150.0%	50.0%	×	141B
F20.28	PMSM Flux weakening control (FR510A only)	0: Invalid 1: Valid	1	×	141C
F20.29	PMSM Flux weakening Voltage (FR510A only)	70.0~100.0%	95.0%	△	141D
F20.30	PMSM Flux weakening gain(Kp) (FR510A only)	0.0~500.0%	30.0%	△	141E
F20.31	PMSM Flux weakening integral(Ti) (FR510A only)	0.00~60.00s	0.5s	△	141F
F20.32	PMSM Flux weakening limit (FR510A only)	0.0~200.0%	100.0%	△	1420
F20.33	PMSM excitation current frequency high point (FR510A only)	F10.34~600.00Hz	15.00Hz	△	1421
F20.34	PMSM excitation current frequency low point (FR510A only)	0.0~F10.33	10.00Hz	△	1422
F20.35	PMSM excitation current conversion delay (FR510A only)	0.0~10.0s	1.0s	△	1423
F20.36	PMSM speed estimation Kp (FR510A only)	0.00~10.00	2.00	△	1424
F20.37	PMSM speed estimation Ti (FR510A only)	0.1~1000.0ms	20.0ms	△	1425
Group F21 Position Control (FR510A only)					
F21.00	Selection of Position Control Mode	0: Non-position control 1: Zero Servo (Frequency Achievement Effective) 2: Zero Servo (Terminal Effective)	0	×	1500

		3: Spindle orientation			
		4: Simple carry			
		5: Pulse train			
F21.01	Position loop gain	0.000~40.000	1.000	△	1501
F21.02	Zero Servo Initiation Frequency	0.00Hz~Fmax	1.00Hz	×	1502
F21.03	Location completion width	0~3000	10	×	1503
F21.04	Location completion time	0.000~40.000s	0.200s	×	1504
F21.05	Spindle orientation position 1	0~40000	0	△	1505
F21.06	Spindle orientation position 2	0~40000	0	△	1506
F21.07	Spindle orientation position 3	0~40000	0	△	1507
F21.08	Spindle orientation position 4	0~40000	0	△	1508
F21.09	Spindle orientation	Unit's place: spindle orientation direction 0: Orient from current direction of rotation 1: Direction from positive direction 2: Orient from reverse direction Ten's place: positioning when parking 0: Do not locate when parking 1: Positioning when parking	00	×	1509
F21.10	Spindle orientation speed	0.00Hz~Fmax	10.00Hz	×	150A
F21.11	Spindle orientation deceleration time	0.0~60.0s	2.0s	×	150B
F21.12	Orientation position confirmation time	0.000~6.000s	0.010s	×	150C
F21.13	Regression Origin Selection	Unit's place: back to origin selection 0: Invalid 1: Valid Ten's place: whether carry requires terminal enable signal 0: no need 1: Need	00	×	150D
F21.14	Regression Origin Direction	0:Forward 1:Reverse	0	×	150E
F21.15	Regression	0.00Hz~600.00Hz	10.00Hz	×	150F

FR500A&FR510A Series Vector Control Inverter

	Origin Frequency 1				
F21.16	Regression Origin Frequency 2	0.00Hz~60.00Hz	1.00Hz	×	1510
F21.17	Carry amount 0 high	0~9999	0	△	1511
F21.18	Carry amount 0 low	0~9999	0	△	1512
F21.19	Carry amount 1 high	0~9999	0	△	1513
F21.20	Carry amount 1 low	0~9999	0	△	1514
F21.21	Carry amount 2 high	0~9999	0	△	1515
F21.22	Carry amount 2 low	0~9999	0	△	1516
F21.23	Carry amount 3 high	0~9999	0	△	1517
F21.24	Carry amount 3 low	0~9999	0	△	1518
F21.25	Carry amount 4 high	0~9999	0	△	1519
F21.26	Carry amount 4 low	0~9999	0	△	151A
F21.27	Carry amount 5 high	0~9999	0	△	151B
F21.28	Carry amount 5 low	0~9999	0	△	151C
F21.29	Carry amount 6 high	0~9999	0	△	151D
F21.30	Carry amount 6 low	0~9999	0	△	151E
F21.31	Carry amount 7 high	0~9999	0	△	151F
F21.32	Carry amount 7 low	0~9999	0	△	1520
F21.33	Selection of Position-Given Mode	0:X7 pulse input 1: Encoder gives A/B phase pulse, A phase ahead B phase 90 reads forward 2: Encoder gives A/B phase pulse, B phase ahead A phase 90 reads forward	0	×	1521
F21.34	Electronic Gear Ratio Molecule	1~9999	1000	×	1522
F21.35	Electronic gear denominator	1~9999	1000	×	1523
F21.36	feed forward gain	0.000~7.000	1.000	△	1524
F21.37	Feedforward filtering time	0.000~7.000s	0.001s	△	1525
F21.38	Position offset change rate	0~9999	800	×	1526
F22Group:Virtual IO					
F22.00	Function selection of	The same as function code F04.00	0	×	1600

	virtual VDI1 terminal				
F22.01	Function selection of virtual VDI2 terminal	The same as function code F04.00	0	×	1601
F22.02	Function selection of virtual VDI3 terminal	The same as function code F04.00	0	×	1602
F22.03	Function selection of virtual VDI4 terminal	The same as function code F04.00	0	×	1603
F22.04	Function selection of virtual VDI5 terminal	The same as function code F04.00	0	×	1604
F22.05	Valid status setting mode of virtual VDI terminals	VDI5, VDI4, VDI3, VDI2, VDI1	00000	×	1605
		0: Validity of VDI depends on virtual VDOx's status			
		1: Validity of VDI set by function code F22.06			
F22.06	Settings of virtual VDI terminal status	VDI5, VDI4, VDI3, VDI2, VDI1	00000	△	1606
		0: Invalid			
		1: Valid			
F22.07	Function selection of virtual VDO1 terminals output	0 : Internal short circuited to physics DIx Other: The same as function code F05.00	0	△	1607
F22.08	Function selection of virtual VDO2 terminals output	0 : Internal short circuited to physics DIx Other: The same as function code F05.00	0	△	1608
F22.09	Function selection of virtual VDO3 terminals output	0 : Internal short circuited to physics DIx Other: The same as function code F05.00	0	△	1609
F22.10	Function selection of virtual VDO4 terminals output	0 : Internal short circuited to physics DIx Other: The same as function code F05.00	0	△	160A
F22.11	Function selection of virtual VDO5 terminals output	0 : Internal short circuited to physics DIx Other: The same as function code F05.00	0	△	160B
F22.12	Virtual VDO1 output delay time	0.0s~6000.0s	0.0s	△	160C
F22.13	Virtual VDO2 output delay	0.0s~6000.0s	0.0s	△	160D

FR500A&FR510A Series Vector Control Inverter

	time				
F22.14	Virtual VDO3 output delay time	0.0s~6000.0s	0.0s	△	160E
F22.15	Virtual VDO4 output delay time	0.0s~6000.0s	0.0s	△	160F
F22.16	Virtual VDO5 output delay time	0.0s~6000.0s	0.0s	△	1610
F22.17	VDO output terminal positive and negative logic	VDO5, VDO4, VDO3, VDO2, VDO1	00000	△	1611
		0: Positive logic			
		1: Negative logic			
Group U00 Status Monitoring					
U00.00	Running frequency	0.00~Fup	0.00Hz	⊙	3000
U00.01	Set frequency	0.00~Fmax	0.00Hz	⊙	3001
U00.02	Output voltage	0~660V	0.0V	⊙	3002
U00.03	Output current	0.0~3000.0A	0.0A	⊙	3003
U00.04	Output power	-3000.0~3000.0kW	0.0kW	⊙	3004
U00.05	Estimated Motor Speed	0~60000rpm	0rpm	⊙	3005
U00.06	Bus voltage	0~1200V	0V	⊙	3006
U00.07	Synchronous Frequency	0.00~Fup	0.00Hz	⊙	3007
U00.08	PLC step	1~15	1	⊙	3008
U00.09	Program Operation Time	0.0~6000.0s(h)	0.0s(h)	⊙	3009
U00.10	PID set	0~60000	0	⊙	300A
U00.11	PID feedback	0~60000	0	⊙	300B
U00.12	Status of DI1~DI5 digital input terminal	DI5 DI4 DI3 DI2 DI1	00000	⊙	300C
U00.13	Status of DI6~DI7 digital input terminal	DI7 DI6	00	⊙	300D
U00.14	Status of digital output terminal	R2 R1 Y2 Y1	0000	⊙	300E
U00.15	AI1 input	0.0~100.0%	0.0%	⊙	300F
U00.16	AI2 input	0.0~100.0%	0.0%	⊙	3010
U00.17	AI3 input	-100.0~100.0%	0.0%	⊙	3011
U00.18	Keypad potentiometer input	0.0~100.0%	0.0%	⊙	3012
U00.19	HI input	0.00~100.00kHz	0.00kHz	⊙	3013
U00.20	AO1 output	0.0~100.0%	0.0%	⊙	3014
U00.21	AO2 output	0.0~100.0%	0.0%	⊙	3015
U00.22	HO output	0.00~100.00kHz	0.00kHz	⊙	3016
U00.23	Temperature of inverter	-40.0℃~120.0℃	0.0℃	⊙	3017
U00.24	Accumulative power-on time	0~65535min	0min	⊙	3018

U00.25	Accumulative running time	0~6553.5min	0.0min	⊙	3019
U00.26	Cumulative power-on time	0~65535h	0h	⊙	301A
U00.27	Cumulative running time	0~65535h	0h	⊙	301B
U00.28	Count value	0~65535	0	⊙	301C
U00.29	Length value	0~65535m	0m	⊙	301D
U00.30	Linear speed	0~65535m/min	0m/Min		301E
U00.31	Output torque	0.0~300.0%	0.0%	⊙	301F
U00.32	PTC motor temperature detection	-40℃~200℃	0℃	⊙	3020
U00.33	Speed that detected by encoder	0~60000rpm	0rpm	⊙	3021
U00.34	Monitoring of encoder line number	0~65535	0	⊙	3022
U00.35	Power consumption	0~65535kWh	0kWh	⊙	3023
U00.36	VDI1~VDI5 input status	VDI5 VDI4 VDI3 VDI2 VDI1	00000	⊙	3024
U00.37	VDO1~VDO5output status	VDO5 VDO4 VDO3 VDO2 VDO1	00000	⊙	3025
U00.38	High speed pulse X7 or the line number of extension card monitoring	0~65535	0	⊙	3026
U00.39	Sine cosine encoder C signal (FR510A only)	0~4096	0	⊙	3027
U00.40	Sine cosine encoder D signal (FR510A only)	0~4096	0	⊙	3028
U00.41	UVW encoder UVW signal (FR510A only)	U V W	000	⊙	3029
Group U01 Fault Record					
U01.00	Code of the latest fault	Err00~Err44	0	⊙	3100
U01.01	Running frequency when the latest fault occurred	0.00~Fup	0.00Hz	⊙	3101
U01.02	Output current when the latest fault occurred	0.0~3000.0A	0.0A	⊙	3102
U01.03	Bus voltage when the	0~1200V	0V	⊙	3103

FR500A&FR510A Series Vector Control Inverter

	latest fault occurred				
U01.04	Cumulative running time when the latest fault occurred	0~65535h	0h	⊖	3104
U01.05	Code of previous fault	Same as U01.00	0	⊖	3105
U01.06	Running frequency when previous fault occurred	0.00~Fup	0.00Hz	⊖	3106
U01.07	Output current when previous fault occurred	0.0~3000.0A	0.0A	⊖	3107
U01.08	Bus voltage when previous fault occurred	0~1200V	0V	⊖	3108
U01.09	Cumulative running time when previous fault occurred	0~65535h	0h	⊖	3109
U01.10	Before-previous fault code	Same as U01.00	0	⊖	310A
U01.11	Running frequency when before-previous fault occurred	0.00~Fup	0.00Hz	⊖	310B
U01.12	Output current when before-previous fault occurred	0.0~3000.0A	0.0A	⊖	310C
U01.13	Bus voltage when before-previous fault occurred	0~1200V	0V	⊖	310D
U01.14	Cumulative running time when before-previous fault occurred	0~65535h	0h	⊖	310E
U01.15	Previous 3 categories of faults	The same with U01.00	Err00	⊖	310F
U01.16	Previous 4 categories of faults	The same with U01.00	Err00	⊖	3110
U01.17	Previous 5 categories of	The same with U01.00	Err00	⊖	3111

	faults				
U01.18	Previous 6 categories of faults	The same with U01.00	Err00	⊙	3112
U01.19	Previous 7 categories of faults	The same with U01.00	Err00	⊙	3113
U01.20	Previous 8 categories of faults	The same with U01.00	Err00	⊙	3114
U01.21	Previous 9 categories of faults	The same with U01.00	Err00	⊙	3115
U01.22	Previous 10 categories of faults	The same with U01.00	Err00	⊙	3116
U01.23	Previous 11 categories of faults	The same with U01.00	Err00	⊙	3117
U01.24	Previous 12 categories of faults	The same with U01.00	Err00	⊙	3118
U01.25	Previous 13 categories of faults	The same with U01.00	Err00	⊙	3119

Chapter 5 Maintenance and Troubleshooting

FR500A&FR510A inverter provides a number of warning information and protection, when a fault occurs, the protective function is activated, the inverter will stop output, inverter fault relay contact, and in the inverter displays the fault code on the display panel. Before seeking service user can press the self-examination tips in this section, analyze problems, and identify solutions. If the problem still cannot be excluded, seek services, or contact the dealer you purchase the drive with my company.

Display	Fault Name	Possible Causes	Solutions
Err01	Accel overcurrent	1: The output circuit is grounded or short circuited. 2: The acceleration time is too short. 3: Manual torque boost or V/F curve is not appropriate. 4: The voltage is too low. 5: The startup operation is performed on the rotating motor. 6: A sudden load is added during acceleration. 7: The AC drive model is of too small power class.	1: Eliminate external faults. 2: Increase the acceleration time. 3: Adjust the manual torque boost or V/F curve. 4: Adjust the voltage to normal range. 5: Select rotational speed tracking restart or start the motor after it stops. 6: Remove the added load. 7: Select an AC drive of higher power class
Err02	Decel overcurrent	1: The output circuit is grounded or short circuited. 2: The deceleration time is too short. 3: The voltage is too low. 4: A sudden load is added during deceleration. 5: The braking unit and braking resistor are not installed.	1: Eliminate external faults. 2: Increase the deceleration time. 3: Adjust the voltage to normal range. 4: Remove the added load. 5: Install the braking unit and braking resistor.
Err03	Constant-speed overcurrent	1: The output circuit is grounded or short circuited. 2: The voltage is too low. 3: A sudden load is added during operation. 4: The AC drive model is of too small power class.	1: Eliminate external faults 2: Adjust the voltage to normal range. 3: Remove the added load 4: Select an AC drive of higher power class.
Err04	Accel overvoltage	1: The input voltage is too high. 2: An external force drives the motor during acceleration. 3: The acceleration time is too short. 4: The braking unit and braking resistor are not installed.	1: Adjust the voltage to normal range. 2: Cancel the external force or install a braking resistor. 3: Increase the acceleration time. 4: Install the braking unit and braking resistor.

Err05	Decel overvoltage	<ol style="list-style-type: none"> 1: The input voltage is too high. 2: An external force drives the motor during deceleration. 3: The deceleration time is too short. 4: The braking unit and braking resistor are not installed. 	<ol style="list-style-type: none"> 1: Adjust the voltage to normal range. 2: Cancel the external force or install the braking resistor. 3: Increase the deceleration time. 4: Install the braking unit and braking resistor.
Err06	Constant-speed overvoltage	<ol style="list-style-type: none"> 1: The input voltage is too high 2: An external force drives the motor during deceleration. 	<ol style="list-style-type: none"> 1: Adjust the voltage to normal range. 2: Cancel the external force or install the braking resistor.
Err07	Bus undervoltage	<ol style="list-style-type: none"> 1: Instantaneous power failure occurs on the input power supply. 2: The AC drive's input voltage is not within the allowable range. 3: The bus voltage is abnormal. 4: The rectifier bridge and buffer resistor are faulty. 5: The drive board is faulty. 6: The main control board is faulty. 	<ol style="list-style-type: none"> 1: Reset the fault. 2: Adjust the voltage to normal range. 3: Contact the agent or Frecon.
Err08	Short circuit	<ol style="list-style-type: none"> 1: The output circuit is grounded or short circuited. 2: The connecting cable of the motor is too long. 3: The module overheats. 4: The internal connections become loose. 5: The main control board is faulty 6: The drive board is faulty. 7: The inverter module is faulty. 	<ol style="list-style-type: none"> 1: Eliminate external faults. 2: Install a reactor or an output filter. 3: Check the air filter and the cooling fan. 4: Connect all cables properly. 5: Contact the agent or Frecon.
Err09	Power input phase loss	<ol style="list-style-type: none"> 1: The three-phase power input is abnormal. 2: The drive board is faulty. 3: The lightning board is faulty. 4: The main control board is faulty. 	<ol style="list-style-type: none"> 1: Eliminate external faults. 2: Contact the agent or FRECON.
Err10	Power output phase loss	<ol style="list-style-type: none"> 1: The cable connecting the AC drive and the motor is faulty. 2: The AC drive's three-phase outputs are unbalanced when the motor is running. 3: The drive board is faulty. 4: The module is faulty. 	<ol style="list-style-type: none"> 1: Eliminate external faults. 2: Check whether the motor Three-phase winding is normal. 3: Contact the agent or Frecon.
Err11	Motor overload	<ol style="list-style-type: none"> 1: F11-17 is set improperly. 2: The load is too heavy or locked-rotor occurs on the motor. 3: The AC drive model is of too 	<ol style="list-style-type: none"> 1: Set F11-17 correctly. 2: Reduce the load and check the motor and the mechanical condition. 3: Select an AC drive of

FR500A&FR510A Series Vector Control Inverter

		small power class.	higher power class.
Err12	Inverter overload	1: The load is too heavy or locked-rotor occurs on the motor. 2: The AC drive model is of too small power class.	1: Reduce the load and check the motor and mechanical condition. 2: Select an AC drive of higher power class.
Err13	External equipment fault	1: External fault signal is input via DI.	Reset the operation.
Err14	Module overheat	1: The ambient temperature is too high. 2: The air filter is blocked. 3: The fan is damaged. 4: The thermally sensitive resistor of the module is damaged. 5: The inverter module is damaged.	1: Lower the ambient temperature. 2: Clean the air filter. 3: Replace the damaged fan. 4: Replace the damaged thermally sensitive resistor. 5: Replace the inverter module.
Err15	EEPROM read/write fault	The EEPROM chip is damaged.	Replace the main control board.
Err16	Motor auto-tuning cancelled	Since the identification process, press STOP / RST key	Press STOP / RST key to reset
Err17	Motor auto-tuning fault	1: the motor and the inverter output terminals are not connected 2: The motor does not disengage the load 3: The electrical fault	1: check the connection between the inverter and motor 2: The motor is disengaged load 3: Check the motor
Err18	Communication overtime error	1: The PC is not working properly 2: The communication line is not normal 3: F15 set communication parameters set incorrectly	1: Check the PC Connection 2: Check the communication cable 3: The communication parameters are set correctly
Err19	PID feedback loss	PID feedback set value is less than F13.24	Check the PID feedback signal or set to an appropriate value F13.24
Err20	Continuous running time reached	Set the running time to reach this function	reference F05.14 Description
Err21	Parameter upload fault	1: Is not installed or is not plugged parameter copy card 2: Parameter copy card anomalies 3: The control board abnormalities	1: a copy of the card is properly installed parameters 2: for technical support 3: for technical support
Err22	Parameter download fault	1: Is not installed or is not plugged parameter copy card 2: Parameter copy card anomalies 3: The control board abnormalities	1: A copy of the card is properly installed parameters 2: For technical support 3: For technical support
Err23	Braking unit fault	1: The brake line failure or damage the brake pipe 2: An external braking resistor is too small	1: Check the brake unit, replace the brake pipe 2: Increasing the braking resistor

Err24	Module temperature detection disconnection	The temperature sensor failure or cable break	For technical support
Err25	Load becoming 0	The AC drive running current is lower than F11.22	Check that the load is disconnected or the setting F11-22 and F11-23 is correct.
Err26	With-wave current limit fault	1: The load is too heavy or locked rotor occurs on the motor. 2: The AC drive model is of too small power class.	1: Reduce the load and check the motor and mechanical condition. 2: Select an AC drive of higher power class.
Err27	Inverter soft-start relay is off	1: The grid voltage is too low 2: Rectifier module failure	1: Check the grid voltage 2: Demand for technical support
Err28	Software version compatibility fault	1: The upper and lower transmission module parameters in the parameter version of the control panel version mismatch.	re-upload module parameters to pass down
Err29	Instantaneous overcurrent	1. Inverter output circuit being grounded or short-circuit; 2. The acceleration and deceleration time is too short; 3. Manually torque boost or V/F curve not appropriate; 4. Voltage too low; 5. Start the running motor; 6. Sudden-load in the acceleration process; 7. Model selection of inverter power is too small.	1. Troubleshooting peripheral problems; 2. To increase the acceleration time; 3. Adjust the manually torque boost or V/F curve; 4. Adjust the voltage to normal range; 5. Select RPM track start or start after motor stopped; 6. Cancel sudden-load; 7. Select the inverter with larger power.
Err30	Instantaneous overvoltage	1: Input voltage is too high; 2. There is external force drag the motor to run in deceleration process; 3. The deceleration time is too short; 4. No installation of braking resistor.	1: Adjust the voltage to normal range; 2. Cancel external force or install brake resistor; 3. To increase the deceleration time; 4. Install braking resistor
Err36	PG card is disconnection (close loop)	PG card detects that the encoder signal is disconnected	Check the cable of encoder
Err37	Over Speed (close loop)	1. Encoder parameters not right 2. F11.41 and F11.42 not unreasonable. 3. No parameter tuning	1. check encoder parameters 2. check the value of F11.41 and F11.42 3. Perform parameter tuning
Err38	Excessive speed deviation (close loop)	1. Motor Locked Rotor 2. Encoder parameters not right 3. F11.43 and F11.44 not unreasonable. 4. Output circuit is abnormal	1. check encoder parameters 2. check the value of F11.43 and F11.44 3. check drive output circuit

FR500A&FR510A Series Vector Control Inverter

Err39	Motor temperature too high	1, PTC sensor configuration not right 2, Motor temperature protection value too small 3, Motor temperature too high	1, Reset PTC sensor parameter 2, Increase motor temperature protection value 3, Waiting until motor is cooled
Err40	The setting running time ends	1, Running time more than F00.25	1. Contact the dealer
Err41	Overload warning	1, when F11.18 = 00100 and the current output amp is more than F11.19	1, Check the current load
Err44	Short circuit to ground	When the ten's place of F02.04 is set and the drive output is circuited to the ground.	1. Check the value of F02.04 and the output circuit of drive

Appendix A: Modbus Communication Protocol

1. Application Scope

1. Applicable series: FRECON FR series inverter.
2. Applicable network: Support Modbus protocol, RTU format, with single-master/multi-slave Communication network of RS485 bus.

The typical RTU message frame format:

Start Bit	Device Address	Function Code	Data	CRC	Stop Bit
T1-T2-T3-T4	8Bit	8Bit	n*8Bit	16Bit	T1-T2-T3-T4

2. Physical Interface

RS485 is asynchronous half-duplex Communication mode. LSB has transmission priority.

Default data format of RS485 terminal: 1-8-N-1, bits rate: 9600bps.

Data format 1-8-N-1, 1-8-O-1, 1-8-E-1, optional bits rates 4800bps, 9600bps, 19200bps, 38400bps, 57600bps and 115200bps can be selected.

Shielded twisted-pair cable is recommended Communication cable to lower external interference.

3. Protocol Format

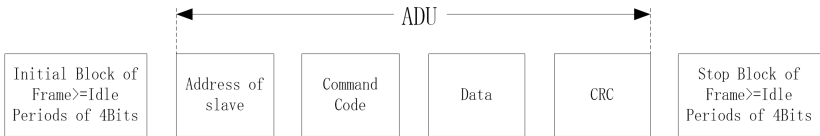

The parity in ADU (Application Data Unit) is obtained via the CRC16 parity of the 1st three Parts of ADU and switch the low bytes and high bytes. Low bytes of CRC parity go first, and high bytes of it follow in the protocol format.

4. Description of Protocol Format

4.1 Address Code

Address of slave inverter. The setting range: 1~247, 0 is broadcast address.

4.2 Command Code

Command Code	Function
03H	Read parameters and status byte of inverter
06H	Write single function code or control parameter of inverter
08H	Circuit diagnosis and setting

4.3 Allocation of Register Addresses

name	Description
Function Code (F00.00~U01.99)	<p>High byte function code group number, F00~F31, U00, U01, respectively, corresponding to the high byte address is 00H~1FH, 30H, 31H.</p> <p>Low byte of the group function code number, from 0 to 99 corresponding to the low byte address is 00H~63H.</p> <p>For example: Modify F01.02 function code value, no power-down when storing the corresponding register address (referred to as RAM address) to 0102H.</p> <p>EEPROM is frequently modified, will reduce the life of the EEPROM. If you modify the value of the function code-down storage needs, you can make this function code is the highest position a high address. Note that this address is only to write, not read.</p> <p>For example: Modify F01.02 function code value, and the corresponding need to power down when storing the register address (referred to as EEPROM address) to 8102H.</p>

Function code group	RAM address high byte	EEPROM address high byte
F00	0x00	0x80
F01	0x01	0x81
F02	0x02	0x82
F03	0x03	0x83
F04	0x04	0x84
F05	0x05	0x85
F06	0x06	0x86
F07	0x07	0x87
F08	0x08	0x88
F09	0x09	0x89
F10	0x0A	0x8A
F11	0x0B	0x8B
F12	0x0C	0x8C
F13	0x0D	0x8D
F14	0x0E	0x8E
F15	0x0F	0x8F
F16	0x10	0x90
F17	0x11	0x91
F18	0x12	0x92
F19	0x13	0x93
F20	0x14	0x94
F21	0x15	0x95
F22	0x16	0x96
U00 (Read Only)	0x30	--
U01 (Read Only)	0x31	--

4.4 Address and control command functions: (write only)

Command word address	Command Function
2000H	0001: Forward run 0002: Reverse Run 0003: Inching Forward 0004: Reverse Jog 0005: Slowdown stop 0006: Freewheel 0007: Fault reset
2001H	Communication setting frequency (0~Fmax (Unit: 0.01Hz))
2002H	PID given range (0 to 1000, 1000 corresponds to 100.0%)
2003H	PID feedback range (0~1000, 1000 corresponds to 100.0%)

2004H	Torque set point (-3000~3000, 1000 corresponds to 100.0% motor rated current)
2005~20FF	Retention

4.5 The status and function of the read address Description: (read only)

Status word address	functional status word
2100H	0000H: parameter setting 0001H: slave run 0002H: JOG operation 0003H: learning run 0004H: Slave parking 0005H: JOG parking 0006H: Fault Status
2101H	Bit0: 0 are given effective 1 Given negative effective Bit1:0 frequency output Forward 1 frequency output inversion Bit2~3: 00 Keyboard start-stop 01 terminal start-stop 10 start-stop communication 11 Reserved Bit4: 0 Factory password is invalid 1 factory password is valid Bit5: 0 user password is invalid 1 valid user password Bit6~7: 00 basic function code group 01 user-defined function code group 10 different functions with the factory default code group 11 Others

5. Explanation of Command**Command code 0x03: Read parameter and status of inverter.**

ADU Item	Byte No.	Range
Master requests:		
Address of slave	1	0~127
Command Code	1	0x03
Register start address	2	0x0000~0xFFFF
The number of register	2	0x0000~0x0008
CRC parity(Low bytes go first)	2	
Slave responds :		
Address of slave	1	The local address
Command Code	1	0x03
Register start address	1	2 number of registers
The number of register	2 number of registers	
CRC parity	2	

Remarks: Read maximum 8 function codes consecutively.

Command code 0x06: Write single function code or control parameter of inverter.

ADU Item	Byte No.	Range
Master requests:		
Address of slave	1	0~127
Command Code	1	0x06

Register start address	2	0x0000~0xFFFF
The number of register	2	0x0000~0xFFFF
CRC parity	2	
Slave responds :		
Address of slave	1	The local address
Command Code	1	0x06
Register start address	2	0x0000~0xFFFF
The number of register	2	0x0000~0xFFFF
CRC parity	2	

Command code 0x08: Circuit Diagnosis and Setting

ADU Item	Byte No.	Range
Master requests:		
Address of slave	1	0~127
Command Code	1	0x08
Register start address	2	0x0000~0xFFFF
The number of register	2	
CRC parity	2	
Slave responds :		
Address of slave	1	The local address
Command Code	1	0x08
Register start address	2	0x0000~0xFFFF
The number of register	2	
CRC parity	2	

Remarks: Command code 0x08 is only for circuit check.

6. CRC Parity

Sending equipment calculates CRC parity value first, and then attaches it to the sending message. Upon receipt of the message, receiving equipment will calculate CRC parity value again, and compare the operation result with received CRC parity value. If the two values are different, it indicates that there is error during transmission.

Calculation process of CRC parity:

1. Define a CRC parity register, and initialize it as FFFFH.
2. Conduct XOR calculation between the first byte of sending message and the value of CRC parity register, and then upload the result to CRC parity register. Start from address code, the start bit and stop bit will not be calculated.
3. Collect and check LSB (the least significant bit of CRC parity register).
4. If LSB is 1, shift each bit of CRC parity register rightwards by 1 bit, the highest bit filled with 0. Conduct XOR calculation between the value of CRC register and A001H, and then upload the result to CRC parity register.
5. If LSB is 0, shift each bit of CRC parity register rightwards by 1 bit, the highest bit filled with 0.
6. Repeat steps 3, 4 and 5 until completing 8 rounds of shifting.
7. Repeat steps 2, 3, 4, 5 and 6, and process the next byte of sending message. Repeat above process continuously until each byte of sending message is processed.
8. CRC parity date will be saved in CRC parity register after calculation.
9. LUT (Look-up table) method is to obtain CRC parity in the system with limited time resources. Simple CRC functions as shown in following (C language Programming):

```

unsigned int CRC_Cal_Value (unsigned char  Data, unsigned char Length)
{
    unsigned int crc_value = 0xFFFF;
    int i = 0;
    while (Length-->0)
    {
        crc_value ^= Data++;
        for (i=0; i<8; i++)
        {
            if (crc_value & 0x0001)
            {
                crc_value = (crc_value>>1) ^ 0xa001;
            }
            else
            {
                crc_value = crc_value>>1;
            }
        }
    }
    return (crc_value);
}

```

7. Error Message Response

Inverter will send an error message report when the master sends error data or inverter receives the error data due to the external interference.

When Communication error occurs, slave combines the highest bit 1 of command code and error code as the response to the master.

Responding data frame format when errors happened in Communication:

ADU Item	Byte No.	Range
Error response:		
Address of slave	1	0~127
Error command code	1	The highest bit 1 of command code
Error code	1	0x01~0x13
CRC parity(Low bytes go first)	2	

Responding command code at normal Communication and error Communication

Responding Command Code at Normal Communication	Responding Command Code at Error Communication
03H	83H
06H	86H
08H	88H

Description of Error Code:

error	Description	error	Description
01H	Exceptional command code	03H	Illegal Data
02H	Exceptional data address	04H	Operation failed

For example, for U00.00 write data 50.00HZ frequency. The host sends the data frame (hex):

01H	06H	30H	00H	13H	88H	8BH	9CH
-----	-----	-----	-----	-----	-----	-----	-----

Because F00.00 is read only, inverter responds error message. Inverter responds data frame in hexadecimal format:

01H	86H	02H	C3H	A1H
-----	-----	-----	-----	-----

Command code is 86H in error message, the highest bit 1 of 06H. If error code detail is 11H, it means the parameter is read only.

After responding to the error data receipt, master can revise the responding program via resending data frame or based on the error message responded by the inverter.

8. Illustration

1, No. 01 reads the output frequency value (U00.00), returned 5000, that 50.00Hz.

To send data:

01 03 30 00 00 01 8B 0A

The received data is:

01 03 02 13 88 B5 12

2, No. 01 Drive communication given frequency 30.00Hz, send the data content of 3000.

To send data:

01 06 20 01 0B B8 D4 88

The received data is:

01 06 20 01 0B B8 D4 88

3, communications sent on the 1st drive forward run command, write to the address 2000H 01

To send data:

01 06 20 00 00 01 43 CA

The received data is:

01 06 20 00 00 01 43 CA

4, No. 01 communications sent inverter deceleration stop command, the address to write to 2000H 05

To send data:

01 06 20 00 00 05 42 09

The received data is:

01 06 20 00 00 05 42 09

Appendix B: Braking Resistor

When the inverter with high inertia loads or need to slow down rapid deceleration, Motor will in the state of power generation, the energy is transferred to the inverter DC link via the inverter bridge, causing the bus voltage of the inverter rises, when more than a certain value, the inverter will report overvoltage fault, and even lead to inverter power module damage of overvoltage, to prevent this happening, you must configure the brake components.

FR500A&FR510A versatile compact inverter series are all built-in brake unit, customers simply external braking resistor can be used. The following is recommended braking resistor power rating and resistance. Depending on the load, the user can change the values appropriately, but must be within the recommended range.

Inverter Model No.	Brake unit	Resistance(Ω)	Quantity	Minimum enabled brake resistance
FR500A-4T-0.7G/1.5PB	Standard built-in	200W 600 Ω	1	100 Ω
FR500A-4T-1.5G/2.2PB		300W 360 Ω	1	100 Ω
FR500A-4T-2.2G/4.0PB		300W 180 Ω	1	100 Ω
FR500A-4T-4.0G/5.5PB		400W 150 Ω	1	100 Ω
FR500A-4T-5.5G/7.5PB		600W 100 Ω	1	80 Ω
FR500A-4T-7.5G/011PB		800W 75 Ω	1	60 Ω
FR500A-4T-011G/015PB		1.1kW 50 Ω	1	43 Ω
FR500A-4T-015G/018PB		1.6kW 40 Ω	1	31 Ω
FR500A-4T-018G/022PB		4.0kW 32 Ω	1	24 Ω
FR500A-4T-022G/030PB		4.5kW 27 Ω	1	24 Ω
FR500A-4T-030G/037PB		6.0kW 20 Ω	1	19.2 Ω
FR500A-4T-037G/045P(B)		7.0kW 20 Ω	1	19.2 Ω
FR500A-4T-045G/055P(B)		9.0kW 13 Ω	1	12.8 Ω
FR500A-4T-055G/075P(B)		11.0kW 10.2 Ω	1	9.6 Ω
FR500A-4T-075G/090P(B)	15.0kW 7.5 Ω	1	6.8 Ω	
FR500A-4T-090G/110P(B)	18.0kW 6.5 Ω	1	6.3 Ω	
FR500A-4T-110G/132P	FRBU-4T-315	26.0kW 6 Ω	1	6 Ω
FR500A-4T-132G/160P		26.0kW 4 Ω	1	4 Ω
FR500A-4T-160G/185P		26.0kW 4 Ω	1	4 Ω
FR500A-4T-185G/200P		38.0kW 3.4 Ω	1	3.4 Ω
FR500A-4T-200G/220P		38.0kW 3.4 Ω	1	3.4 Ω
FR500A-4T-220G/250P		42.0kW 3 Ω	1	3 Ω
FR500A-4T-250G/280P		42.0kW 3 Ω	1	3 Ω
FR500A-4T-280G/315P		54.0kW 2 Ω	1	2 Ω
FR500A-4T-315G/355P		54.0kW 2 Ω	1	2 Ω

***Note: The model of FR510A series inverter only needs to replace FR500A in the above table with FR510A**

Remark:

Multiple braking resistors are connected in parallel mode. For example FR500A-4T-022G/030PB inverter braking resistor selection: Recommend selecting two 2KW, 30 Ω resistor in parallel connection, Equivalent braking resistor is 4KW, 15 Ω .

If the power rating over 90kw, please refer to 《FRBU User's Manual Of Braking Unit》 to select the braking resistor.

Cables listed in above table refer to the lead cable of single resistor. The DC bus should be updated if the resistors are in parallel connection. Cable should withstand voltage above AC450V, and temperature resistance of cable: 105 $^{\circ}$ C.

Appendix C: PG Card

FR510A series is equipped with PG cards showed as below, as optional parts, is the necessary part for inverter with closed loop vector control mode. PG card feedback the real-time speed of motor through the signal acquisition from encoder to achieve the precise control of motor speed and steering

Model	Description	Connection mode
EXC-PG01	The differential input PG card	Terminal connection
EXC-PG02	Open collector,push input PG card	Terminal connection
EXC-PG03	Rotary transformer PGcard	DB9 interface
EXC-PG04	UVW encoder PG card	Terminal connection
EXC-PG05	ECN1313 PG card	Terminal connection
EXC-PG06	Sin-Cos encoder PG card	DB15 interface

Relative Parameters

Function code	Code Name	Setting Range	Default	Attr				
F00.08	Motor control method	Unit's place: Motor1 control method	11	×				
		0: V/F control						
		1: Sensor-less vector control mode1						
		2: Sensor-less vector control mode2						
		3: Close-loop control(with PG card)						
		Ten's place: Motor2 control method						
		0: V/F control						
		1: Sensor-less vector control mode1						
F08.23	Encoder line count	0-65535	1024	×				
		F08.24			Encoder selection	0: ABZ incremental encoder	0	×
						1: UVW incremental encoder		
						2: Rotary transformer		
						3: ECN1313		
4: Sin-Cos encoder								
F08.25	AB phase sequence	0: Positive	0	×				
		1: Negative						
F08.30	Auto-tuning	0: No autotuning	0	×				
		1: Static autotuning of motor						
		2: Rotary autotuning of motor						

Set these parameter according to different encoder

Function code explanation:

- 1)F00.08 = 33(Close-loop control,with PG card)
- 2)When choosing ABZ incremental encoder, F08.24 should be rightly set.
- 3)When choosing ABZ incremental encoder, need to check that AB phase sequence is the same with frequency.

Installation diagram shown as below C-1:

- 1) All kinds of PG cards are installed in the same place
- 2) Cut off the power when to install PG card or uninstall it.
- 3) Connecting the 20 PIN interface of PG card to J3 interface of control board.

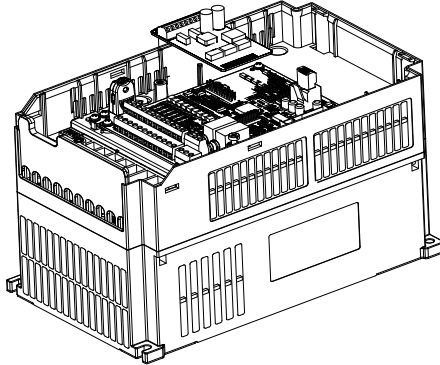

Fig.C-1 PG card installation

C.1 ABZ encoder PG card

External view:

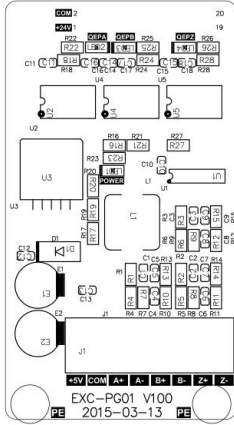

Fig.C-2(a)EXC-PG01

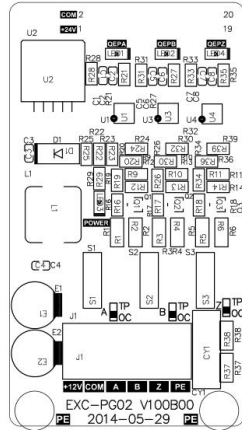

Fig.C-2(b)EXC-PG02

Table C-1 Technical parameter

Model	Power	Characteristics of the input signal		Characteristics of the output signal	
		Response frequency range	Input impedance	Output frequency range	Output current
EXC-PG01	5V	0-300KHz		0-300KHz	200mA
EXC-PG02	12V	0-80KHz		0-80KHz	100mA

Terminals outline drawing:

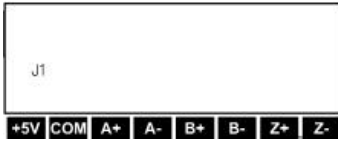

Fig.C-3(a)EXC-PG01 terminals



Fig.C-3(b)EXC-PG02 terminals

Table C-2 Terminal function description

Model	Connection object	Interface name	Description
EXC-PG 01	The differential input incremental encoder interface	A+、A-	Encoder output singal A, maximum frequency 300kHz
		B+、B-	Encoder output signal B, maximum frequency 300kHz
		Z+、Z-	Encoder output singal Z, zero signal
		+5V	Supply +5V/200mA power
		COM	Power earthing
EXC-PG 02	Open collector, Push input incremental encoder interface	+12V	Supply +12V/100mA power
		COM	Power earthing
		A	Encoder output singal A, maximum frequency 80kHz
		B	Encoder output singal B, maximum frequency 80kHz
		Z	Encoder output singal Z, zero signal
		PE	Shielding line

Schematic diagram of the application connection

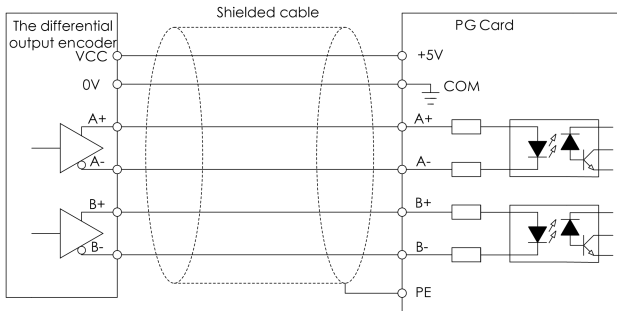
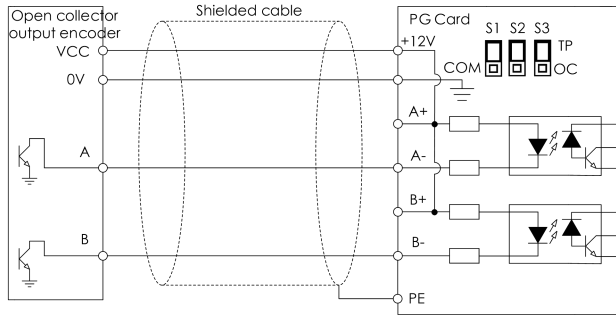
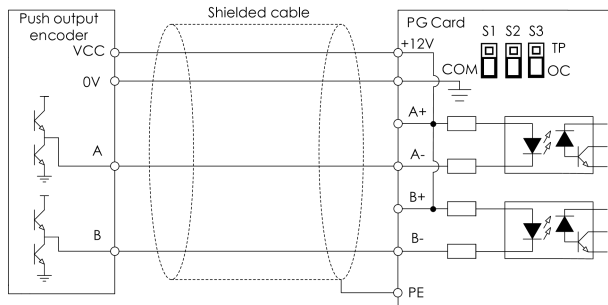

Fig. C-4 Connection schematic diagram of EXC-PG01 and the differential output encoder



**Fig. C-5 Connection schematic diagram of EXC-PG01
and the open collector output encoder**



**Fig. C-6 Connection schematic diagram of EXC-PG01
and the push output encoder**

Usage method

- 1) Follow Figure C-1 to loading PG card
- 2) Follow Figure C-4、C-5、C-6 to connect PG card and encoder
- 3) Shielded cable earthing line PE is connected directly to the fixed screw of PG card
- 4) According to the actual situation to set the inverter parameters as follow:

Parameter setting	Description
F00.08 = 3	Close-loop control(with PG card)
F08.23 = 1024	Encoder line number, setting as the specification of encoder
F08.24 = 0	ABZ incremental encoder
F08.25 = 0	AB phase sequence.

C.2 Rotary transformer PG card

Outline and its interface:

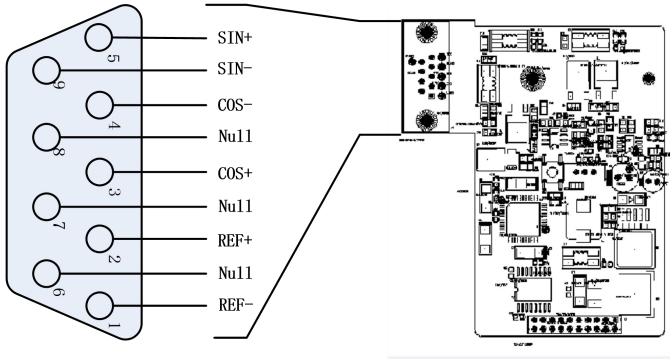

Fig.C-7 EXC-PG03 Schematic diagram and its DB9 pin interface

DB9 PIN

PIN	1	2	3	4	5	6	7	8	9
Name	REF-	REF+	COS+	COS-	SIN+	Null	Null	Null	SIN-

PIN function

Model	Connecting object	Pin name	Description
EXC-PG03	Rotary transformer	COS+, COS-	Cosine signal
		SIN+, SIN-	Sine signal
		REF+, REF-	Voltage reference signal
		Null	Null

Usage method

- 1) Follow Figure C-1 to loading PG card
- 2) Shielded cable earthing line PE is connected directly to the fixed screw of PG card
- 3) According to the actual situation to set the inverter parameters as follow:

Parameter setting	Description
F00.08 = 3	Close-loop control(with PG card)
F08.24 = 2	Select the rotary transformer

C.3 UVW Encoder PG card

There are two types of PG card of UVW encoder: one can only accept signals from encoder (exc-pg04b); the other can accept AB signals from upper computer (exc-pg04) in addition to encoder signals.

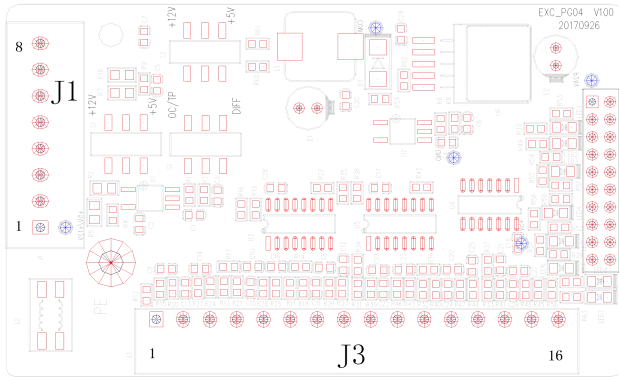

Fig c-8a EXC-PG04

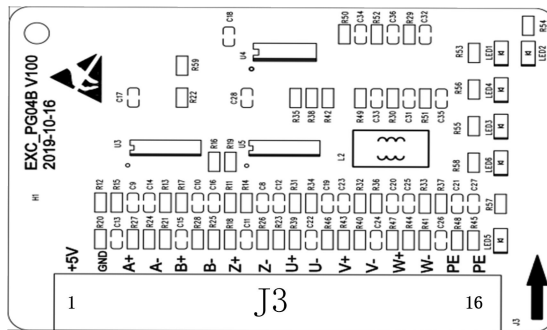

Fig c-8b EXC-PG04B

J1 terminal description:

J1 is mainly used to receive a and B signals from the upper computer, which is generally not used.

No.	Terminal Name	Description
1	VCC	Power input
2	COM	common end
3	QA+	signal A+
4	QA-	signal A-
5	QB+	signal B+
6	QB-	signal B-
7	VCC	Power input
8	COM	common end

J3 terminal description:

J3 terminal is used to receive signals from UVW encoder.

No.	Terminal Name	Description
1	5V	+5V power
2	GND	GND
3	A+	Encoder differential signal A+
4	A-	Encoder differential signal A-
5	B+	Encoder differential signal B+
6	B-	Encoder differential signal B-
7	Z+	Encoder differential signal Z+
8	Z-	Encoder differential signal Z-
9	U+	Encoder differential signal U+
10	U-	Encoder differential signal U-
11	V+	Encoder differential signal V+
12	V-	Encoder differential signal V-
13	W+	Encoder differential signal W+
14	W-	Encoder differential signal W-
15,16	PE	Shielding ground

◆ Usage method

- 1) Install the PG card according to figure C-1
- 2) Shielding cable ground PE can be directly punched on PG card fixing screw
- 3) Set the converter parameters according to the actual situation, as follows:

Function code set	Description
F00.08 = 3	With PG vector control mode
F08.24 = 1	UVW Encoder

C.4 ECN1313 PG Card

Outline and its interface:

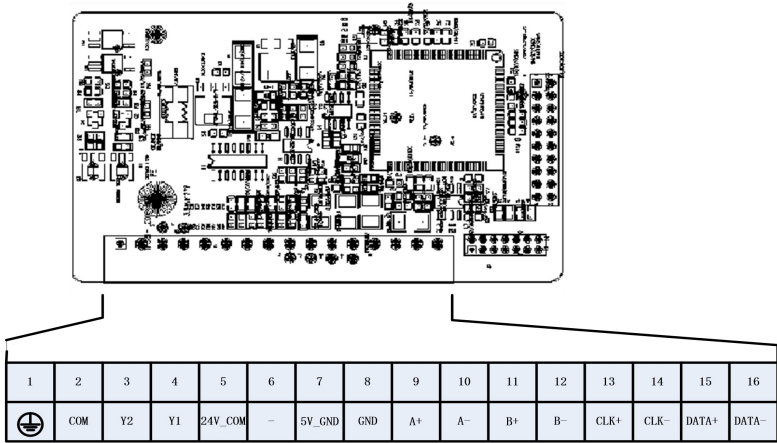

Fig.C-9 EXC-PG05 ECN1313 PG terminals

Terminals:

Model	Connecting Object	Pin Name	Description
EXC-PG05	ECN1313 Encoder		GND
		24_COM、COM	24V output and its common terminal
		5V_GND、GND	5V output and its ground
		A+、A-	A differential signal
		B+、B-	B differential signal
		Y1	B signal OC output (24V)
		Y2	A signal OC output (24V)
		CLK+、CLK-	ECN1313 differential clock input
DATA+、DATA-	ECN1313 differential data input		

Usage method

- 1) Follow Figure C-1 to loading PG card
- 2) Shielded cable earthing line PE is connected directly to the fixed screw of PG card
- 3) According to the actual situation to set the inverter parameters as follow:

Parameter setting	Description
F00.08 = 3	Close-loop control(with PG card)
F08.24 = 3	Select the ECN1313 encoder

C.5 Sin-Cos encoder PG card

Outline and its interface:

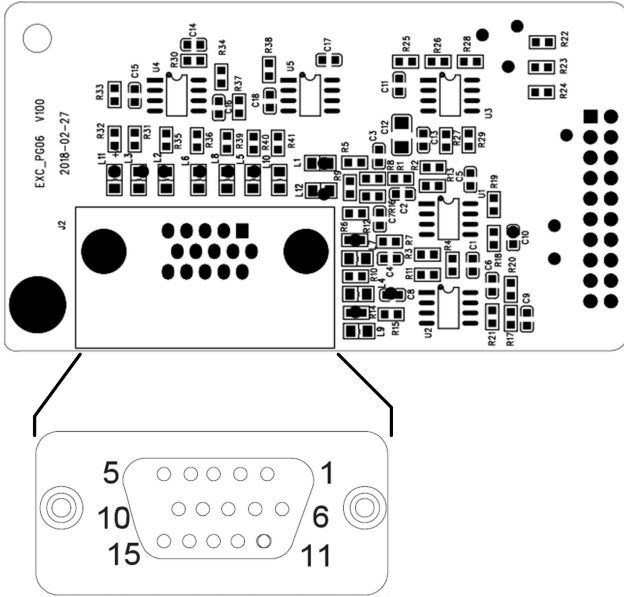

Fig.C-10 EXC-PG06 Sin-Cos encoder PG card

DB15 PIN:

Num.	Pin Name	Description
1	B-	Differential signal B-
2	NC	Null
3	R+	Differential signal R+
4	R-	Differential signal R-
5	A+	Differential signal A+
6	A-	Differential signal A-
7	GND	Power ground
8	B+	Differential signal B+
9	PG VCC	+5V Power
10	C+	Differential signal C+
11	C-	Differential signal C-
12	D+	Differential signal D+
13	D-	Differential signal D-
14、 15	NC	Null