



## Contents

<b>CONTENTS</b> .....	- 1 -
<b>CHAPTER 1 PRODUCT INFORMATION</b> .....	- 2 -
1.1 NAMEPLATE INFORMATION.....	- 2 -
1.2 FR500F SPECIAL PURPOSE INVERTER MODEL SELECTION.....	- 3 -
1.3 CONFIGURATION, MOUNTING DIMENSIONS AND WEIGHT.....	- 4 -
1.4 PRODUCT TERMINALS CONFIGURATION.....	- 6 -
<b>CHAPTER 2 DEBUGGING GUIDE</b> .....	- 11 -
2.1 SPINNING CONTROL.....	- 11 -
2.2 TWO CONTROL MODES.....	- 11 -
2.3 POWER-OFF MEMORY FUNCTION.....	- 13 -
<b>CHAPTER 3 LIST OF PARAMETER</b> .....	- 14 -
3.1 FIVE LED (DIGITAL) DISPLAY INDICATORS.....	- 15 -
3.2 STANDARD FUNCTION PARAMETERS.....	- 15 -
3.3 H00 TEXTILE-SPECIFIC FUNCTION GROUP EXPLANATION.....	- 41 -
<b>CHAPTER 4 MAINTENANCE AND TROUBLESHOOTING</b> .....	- 47 -

## Chapter 1 Product Information

### 1.1 Nameplate Information

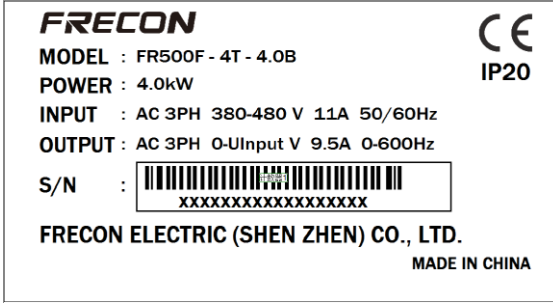

Figure 1-1 Nameplate Information

#### Model Instruction

Model numbers on nameplate consist of numbers, symbols, and letters, to express its respective series, suitable power type, power level and other information.

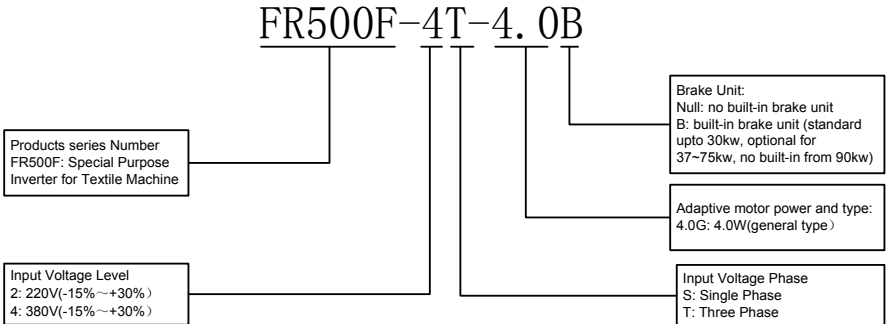

Figure 1-2 Product Model Naming Rules

## 1.2 FR500F Special Purpose Inverter Model Selection

Table 1-1 FR500F Series Product Model and Technical Data

Model No.	Power capacity KVA	Rated Input current A	Rated output current A	Applicable motor	
				kW	HP
3-Phase:380V, 50/60Hz		Range:-15%~+30%			
FR500F-4T-0.7B	1.5	3.4	2.5	0.75	1
FR500F-4T-1.5B	3	5.0	4.2	1.5	2
FR500F-4T-2.2B	4	5.8	5.5	2.2	3
FR500F-4T-4.0B	6	11	9.5	3.7, 4	5
FR500F-4T-5.5B	8.9	14.6	13	5.5	7.5
FR500F-4T-7.5B	11	20.5	17	7.5	10
FR500F-4T-011B	17	26	25	11	15
FR500F-4T-015B	21	35	32	15	20
FR500F-4T-018B	24	38.5	37	18.5	25
FR500F-4T-022B	30	46.5	45	22	30
FR500F-4T-030B	40	62	60	30	40
FR500F-4T-037(B)	57	76	75	37	50
FR500F-4T-045(B)	69	92	91	45	60
FR500F-4T-055(B)	85	113	112	55	70
FR500F-4T-075(B)	114	157	150	75	100
FR500F-4T-090(B)	134	186	176	90	125
FR500F-4T-110	160	220	210	110	150
FR500F-4T-132	192	260	253	132	175
FR500F-4T-160	231	310	304	160	210
FR500F-4T-185	240	355	350	185	250
FR500F-4T-200	250	382	377	200	260
FR500F-4T-220	280	430	426	220	300
FR500F-4T-250	355	475	470	250	330
FR500F-4T-280	396	535	520	280	370
FR500F-4T-315	445	610	600	315	420
FR500F-4T-355	500	665	650	355	470
FR500F-4T-400	565	690*	725	400	530
FR500F-4T-450	623	765*	800	450	600

### 1.3 Configuration, Mounting Dimensions and Weight

◆0.7~2.2KW Dimensions and wall mounting dimensions:

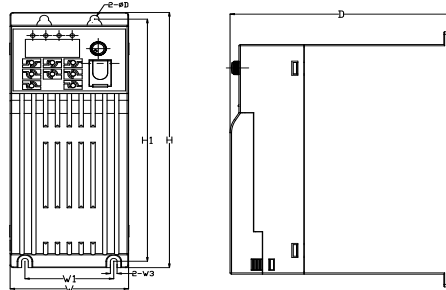

Fig 1-3 0.7~2.2kW Wall installation diagram

◆4~22KW Dimensions and wall mounting dimensions:

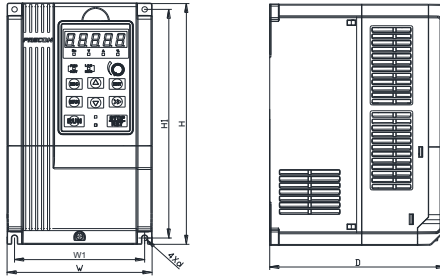

Fig 1-4 4~22kW Wall installation diagram

◆30~450kW Dimensions and wall mounting dimensions:

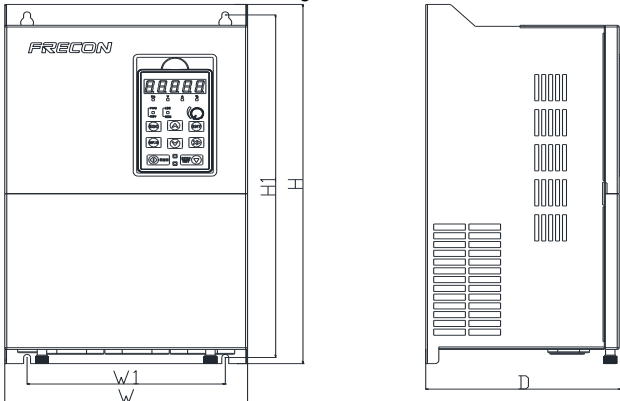

Fig 1-5 30~355KW Wall installation diagram

Table 1-2 Configuration, mounting dimensions and weight

Model NO.	External and installation dimensions (mm)						Weight (Kg)
	W	W1	H	H1	D	Mounting Hole Diameter	
3-Phase:380V, 50/60Hz Range:-15%~+30%							
FR500F-4T-0.7B	80	60	200	190	150	6	1.25
FR500F-4T-1.5B							
FR500F-4T-2.2B	116.6	106.6	186.6	176.6	175	4.5	2.5
FR500F-4T-4.0B							
FR500F-4T-5.5B							
FR500F-4T-7.5B	146	131	249	236	177	5.5	3.9
FR500F-4T-011B							
FR500F-4T-015B	198	183	300	287	185	5.5	6.2
FR500F-4T-018B							
FR500F-4T-022B							
FR500F-4T-030B	245	200	410	391	200	7	11.8
FR500F-4T-037	300	200	485	466	226	7	15
FR500F-4T-045							
FR500F-4T-055							
FR500F-4T-075	310	200	620	601	262	9.5	26
FR500F-4T-090							
FR500F-4T-110	310	200	650	620	350	11.5	45
FR500F-4T-132							
FR500F-4T-160	400	300	750	724	300	11.5	68
FR500F-4T-185	500	300	855	822	320	12	112
FR500F-4T-200							
FR500F-4T-220							
FR500F-4T-250	540	340	924.5	896	380	12	120
FR500F-4T-280							
FR500F-4T-315	620	400	996	963	390	12	133
FR500F-4T-355							
FR500F-4T-400	700	500	1025.5	988.5	390	14	
FR500F-4T-450							

## 1.4 Product Terminals Configuration

### 1.4.1 Main Circuit Terminals

◆ 0.7~2.2kW Main Circuit Terminals

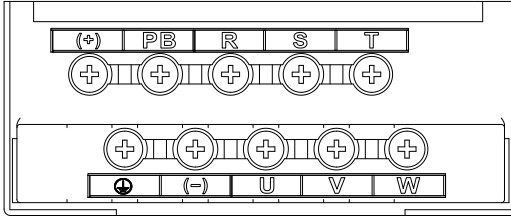

Fig.1-6 0.7~2.2kW Schematic of main circuit terminals

◆ 4~5.5kW Main Circuit Terminals

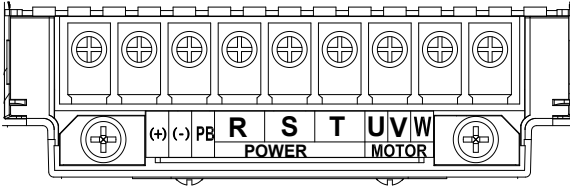

Fig.1-7 4~5.5kW Schematic of main circuit terminals

◆ 7.5~22kW Main Circuit Terminals

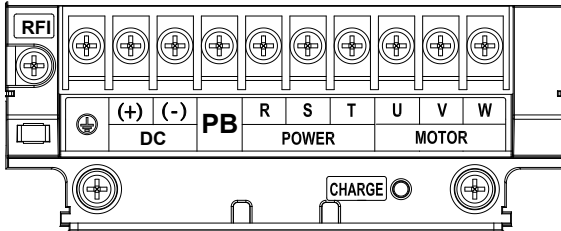

Fig.1-8 7.5~22kW Schematic of main circuit terminals

◆30~37KW Main Circuit Terminals

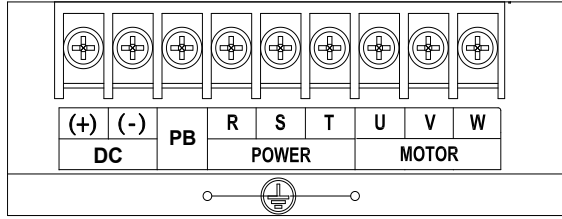

Fig.1-9 30~37kW Schematic of main circuit terminals

◆45~90KW Main Circuit Terminals:

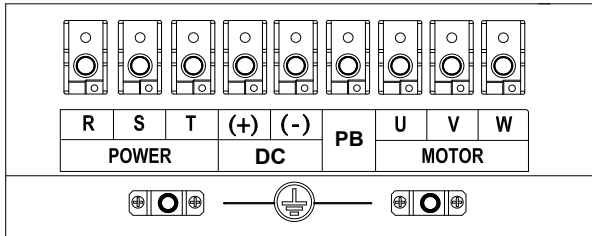

Fig.1-10 45~90kW Schematic of main circuit terminals

◆110~132KW , 250~280KW ,315~450KW Main Circuit Terminals:

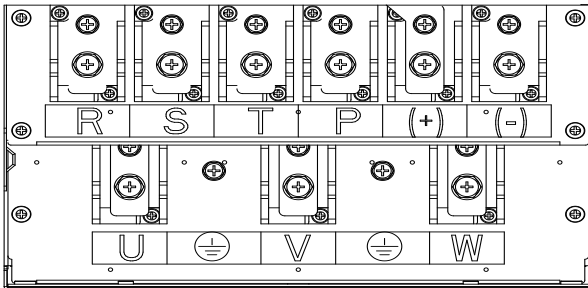

Fig.1-11 110~132KW , 250~280KW ,315~355KW Main Circuit Terminals

# FR500F Series Special Purpose Inverter

## ◆160~220KW Main Circuit Terminals:

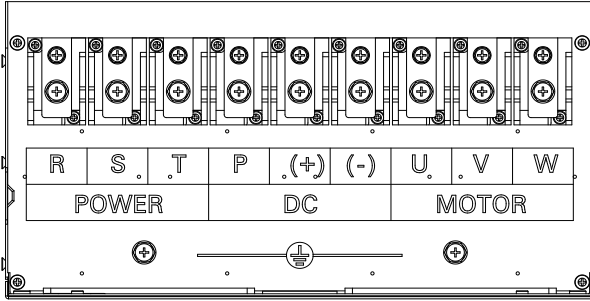

Fig.1-11 160~220KW Main Circuit Terminals

Main circuit terminal functions

Terminal marks	Designation and function of terminals.
R, S, T	AC power input terminals for connecting to 3-phase AC380V power supply.
U, V, W	AC output terminals of inverter for connecting to 3-phase induction motor.
(+), (-)	Positive and negative terminals of internal DC bus.
PB	Positive and negative terminals of internal DC bus. Connecting terminals of braking resistor. One end connected to + and the other to PB.
⊥	Grounding terminal.

**Remarks:** No phase sequence requirements on wiring of the input side of inverter. Wiring

Precautions:

1) Power input terminals R/L1, S/L2, T/L3

◆ The cable connection on the input side of the AC drive has no phase sequence requirement.

2) DC bus (+), (-)

◆ Terminals (+) and (-) of DC bus have residual voltage after the AC drive is switched off. After indicator CHARGE goes off, wait at least 10 minutes before touching the equipment. Otherwise, you may get electric shock.

◆ Do not connect the braking resistor directly to the DC bus. Otherwise, it may damage the AC drive and even cause fire.

3) Braking resistor connection terminals (+), PB

◆ The cable length of the braking resistor shall be less than 5 m. Otherwise, it may damage the AC drive.

4) AC drive output terminals U/T1, V/T2, W/T3

◆ The capacitor or surge absorber cannot be connected to the output side of the AC drive. Otherwise, it may cause frequent AC drive fault or even damage the AC drive.

If the motor cable is too long, electrical resonance will be generated due to the impact of distributed capacitance. This will damage the motor insulation or generate higher leakage current, causing the AC drive to trip in overcurrent protection. If the motor cable is greater than 100 m long, an AC output reactor must be installed close to the AC drive.

5) Terminal ⊥PE

◆ This terminal must be reliably connected to the main earthing conductor. Otherwise, it may cause electric shock, mal-function or even damage to the AC drive.

◆ Do not connect the earthing terminal to the neutral conductor of the power supply.



## 1.4.2 Control circuit terminals

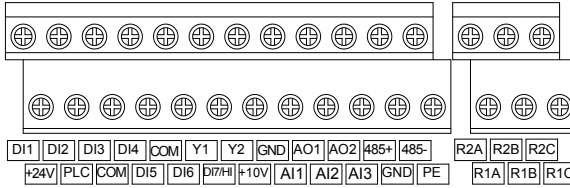



Figure 1-14 Control circuit terminals diagram

Table 1-4 FR500F Control circuit terminals functions

Type	Terminal Marks	Name	Function Description
Power supply	+10V-GND	+ 10V power supply	Provide +10 V power supply to external unit. Maximum output current: 10 mA Generally, it provides power supply to external potentiometer with resistance range of 1–5 kΩ.
	+24V-COM	24V power supply	Provide +24 V power supply to external unit. Generally, it provides power supply to DI/DO terminals and external sensors. Maximum output current: 200 mA
	PLC	Input terminal of external power supply	Connect to +24 V by default. When DI1-DI7 need to be driven by external signal, PLC needs to be connected to external power supply and be disconnected from +24 V.
Analog input	AI1-GND	Analog input 1	Input range: DC 0~10V/0~20mA, selected by toggle switches AI1、AI2 on control board Input Impedance: 250 kΩ (voltage input), 250 Ω (current input)
	AI2-GND	Analog input 2	
	AI3-GND	Analog input 3	Input Voltage Range: DC -10~+10V Input impedance: 250kΩ
Switch input	DI1- COM	Switch input terminals 1	Maximum input frequency: 200Hz Impedance: 2.4kΩ Voltage range for level input: 9V~30V
	DI2- COM	Switch input terminals 2	
	DI3- COM	Switch input terminals 3	
	DI4- COM	Switch input terminals 4	
	DI5- COM	Switch input terminals 5	
	DI6- COM	Switch input terminals 6	
	DI7/Hi-COM	Switch input terminals 7 or high-speed pulse input	Besides features of DI1–DI6, it can be used for high-speed pulse input. Maximum input frequency: 100 kHz
Analog Output	AO1-GND	Analog Output 1	Output range: DC 0~10V/0~20mA, selected by toggle switches AO1、AO2 on control board Impedance requirements≥10kΩ
	AO2-GND	Analog Output 2	
Switch Output	Y1-COM	Open collector output 1	Voltage range: 0~24V Current range: 0~50mA
	Y2/HO-COM	Open collector output 2 or	Besides features of Y1, it can be used for high-speed pulse output channels.

## FR500F Series Special Purpose Inverter

		high-speed pulse output	The maximum output frequency: 100kHz
Relay Output	R1A-R1C	Normally open terminal	Contact driving capacity: AC250V, 3A, COS $\phi$ =0.4. DC 30V, 1A
	R1B-R1C	Normally close terminal	
	R2A-R2C	Normally open terminal	
	R2B-R2C	Normally close terminal	
485 communication	485+-485-	485 communication terminal	Rate: 4800/9600/19200/38400/57600/115200bps Terminal matching resistor is set by the toggle switch on control panel RS485
	GND	485 Communication shielded ground	
Shield	PE	Shield Ground	Ground terminal for shield Use for terminal wirings shield grounding
Auxiliary Interface		External operation panel interface	Use standard network cable Maximum communication distance is 50m for connecting to operation panel, adopt standard network cable (RJ45)
	UP/DOWNL OAD	Parameter copy interface	

## Chapter 2 Debugging Guide

### 2.1 Spinning Control

The Spinning Control application program is designed to run spinning bobbins in ring frame textile machine. To achieve the best possible form for the doff, the spinning sequence should be ideal for a traverse of the yarn. This is done by giving pre-set values for speed based on time elapsed. The following figure shows the principle of spinning control.

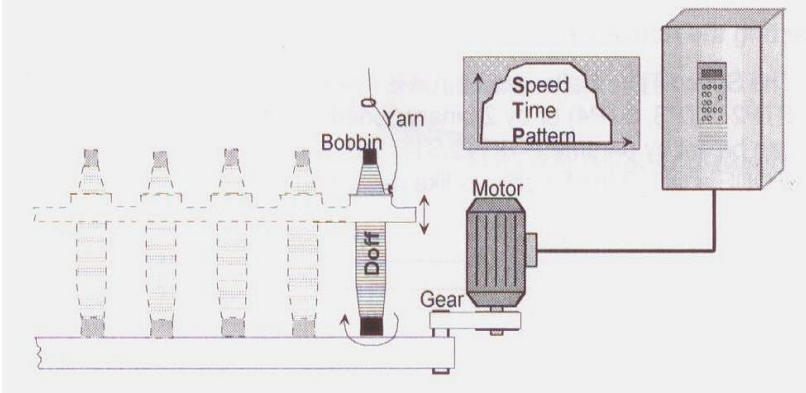

Figure 2-1 Spinning Control Diagram

Wirings as below:

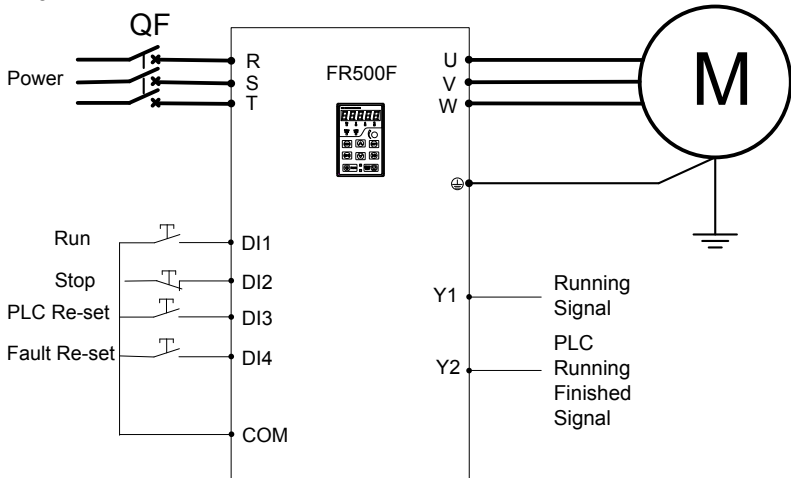

Figure 2-2 Spinning Inverter External Wirings

### 2.2 Two Control Modes

FR500F series special purpose inverter for textile machine has Three control modes, users can freely choose any mode by parameters setting, and details refer to parameter H00.34.

#### 1. Linear Mode

Linear mode can set 16 multi-steps in total, and every step running speed can be set. First,

## FR500F Series Special Purpose Inverter

when inverter running into any step, timer starts, and running to this step by acce/dece time, after reach the step, inverter continue to run as this step until timing arrived at the time set by this step, running figure as below:

### Output Frequency(Hz)

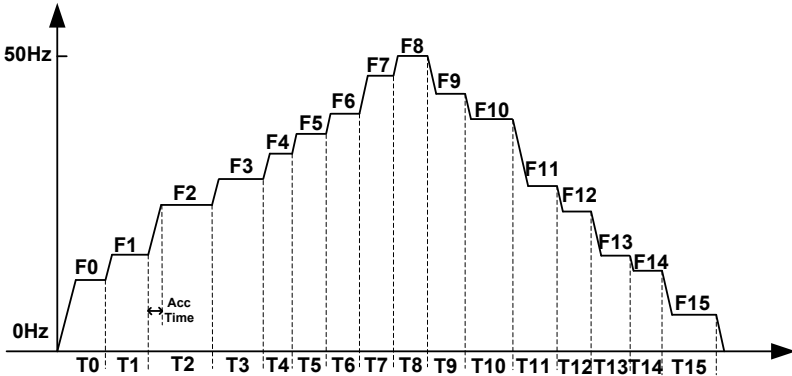

Figure 2-3 linear mode running diagram

### 2. Gradual Mode

Gradual mode can set 16 multi-steps in total, also can set the time from current step to next step. When running, inverter gradually change to next step from current step, total consuming time is the set time. When PLC running finished, inverter will stop according to dece time, running diagram as below:

### Output Frequency(Hz)

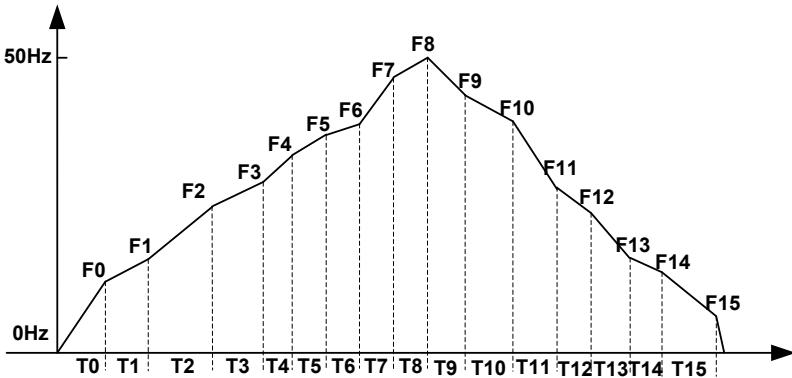

Figure 2-4 gradual mode running diagram

### 3: Length Mode

Frequency gradually changed from current speed to next setting speed, total consuming length is set length (Length is calculated according to current frequency or to pulse input). When PLC running finished, inverter stops according to the deceleration time, running diagram as below:

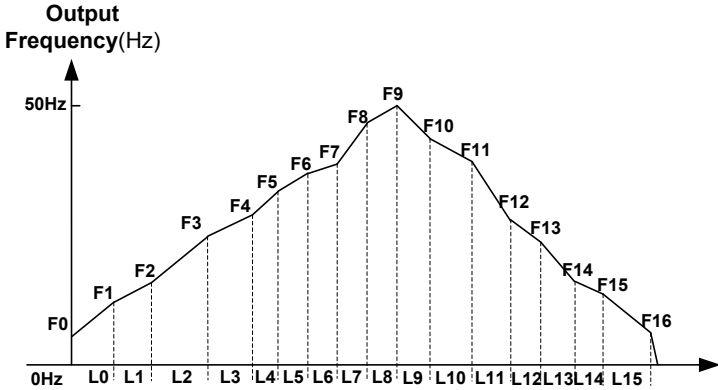

Figure 2-5 Length mode running diagram

### 2.3 Power-off Memory Function

FR500F series special purpose inverter for textile machine has power-off memory function, details refer to the function code H00.33. When power-off function selection valid, inverter can remember the step running before power-off, and already finished running time during this step, when starts again, inverter can finish the remaining step and time, details as below:

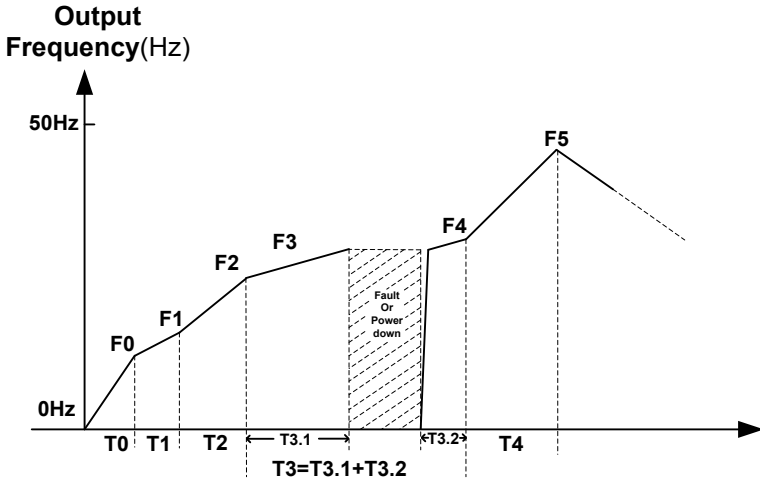

Figure 2-6 power-off memory function diagram

## Chapter 3 List of Parameter

Group F00~F17 are standard function parameters. Group U00 is status monitoring parameters. Group U01 is fault record parameters.

The symbols in the function code table are described as follows:

"Δ" means the value of this parameter can be modified in stop and running status of drive;

"x" means the value of this parameter cannot be modified when drive is running;

"⊙" means this parameter is a measured value that cannot be modified;

Default: The value when restored to factory default. Neither measured parameter value nor recorded value will be restored.

Setting Range: the scope of setting and display of parameters

FR500F parameter groups are listed below:

Category	Parameter Group
System Parameters	F00: System Parameters
Basic Parameters	F01: Frequency Command
	F02: Start/Stop Control Start/Stop Control
	F03: Accelerate/Decelerate Parameters
Input & Output Terminals	F04: Digital Input
	F05: Digital Output
	F06: Analog and Pulse Input
	F07: Analog and Pulse Output
Motor and Control Parameters	F08: Parameters of Motor 1
	F09: V/f Control Parameters of Motor 1
	F10: Vector Control Parameters of Motor 1
Protection Parameters	F11: Protection Parameters
Application Parameters	F12: Multi-Reference and Simple PLC Function
	F13: Process PID
	F14: Swing Frequency, Fixed Length , Count and Wakeup
Communication Parameters	F15: Communication Parameters
Keys and Display of Keypad Parameters	F16:Keys and Display of Keypad Parameters
User-defined Display Parameters	F17:User-defined Display Parameters
Monitoring Parameters	U00:Status monitoring
	U01:Fault record

### 3.1 Five LED (digital) display indicators

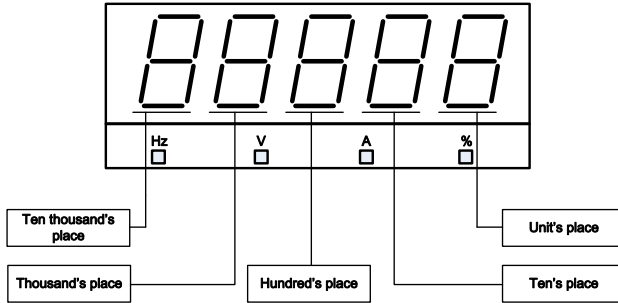

Fig.3-1 LED indicators

### 3.2 Standard Function Parameters

Table 3-1 Standard Function Parameters

Param.	Parameter Name	Setting Range	Default	Attr
<b>Group F00: System Parameters</b>				
F00.00	Setting of User Password	0~65535	0	×
F00.01	Display of Parameters	0: Display all parameters 1: Only display F00.00, F00.01 and user-defined parameters F17.00~F17.29 2: Only display A0-00, A0-01, and the parameters different with factory default	1	×
F00.02	Parameter Protection	0: All parameter programmable 1: Only F00.02 and this parameter programmable	0	×
F00.03	G/P type display	0: G type (constant torque load) 1: P type (variable torque load e.g. fan and pump)	0	×
F00.04	Parameter Initialization	0: No operation 1: Restore all parameters to factory default (excluding motor parameters) 2: Clear fault record 3: Back up current user parameters 4: Restore user backup parameters 5: Restore factory default(include motor parameter) 6: Power consumption zero clearing(U00.35)	0	×
F00.05	Copy of Parameters	0: No operation 1: Upload parameter 2: Download parameter (excluding motor parameters) 3: Download parameter (including motor parameters)	0	×
F00.06	Parameter editing mode	0: Editable via keypad and RS485 1: Editable via keypad	0	×

# FR500F Series Special Purpose Inverter

		2: Editable via RS485		
F00.08	Motor 1 control mode	0: Voltage/Frequency (V/F) control	1	×
		1: Sensor-less vector control 1		
		2: Sensor-less vector control 2		
F00.09	DI7/HI input mode	0: Digital input terminal 7	0	×
		1: Pulse input		
F00.10	AI1\AI2\AI3 input mode	Unit's place: AI1	000	×
		0: Analog input		
		1: Digital input		
		Ten's place: AI2 (same as AI1)		
		Hundred's place: AI3 (same as AI1)		
F00.11	Y2/HO input mode	0: Digital Output terminal 2	0	×
		1: Pulse output		
F00.12	PWM optimization	Unit's place: PWM modulation mode 0: Fixed carrier 1: Random carrier 2: Derating of fixed carrier 3: Derating of random carrier	000	×
		Ten's place: PWM modulation mode 0: Seven-segment mode 1: Five-segment mode 2: Five-segment and seven-segment automatic switchover		
		Hundred's place: over-modulation coefficient 0: Invalid 1~9: 1.01~1.09 times of over-modulation		
F00.13	Carrier frequency	0.700~16.000kHz	Model defined	△
F00.14	Upper carrier frequency	0.700~16.000kHz	8.000kHz	×
F00.15	Lower carrier frequency	0.700~16.000kHz	2.000kHz	×
F00.16	Output voltage	5.0~150.0%	100.0%	×
F00.17	AVR	0: Disabled	0	×
		1: Enabled		
		2: AVR is disabled if the DC bus voltage > the rated voltage of DC bus, and it will be enabled if the DC bus voltage ≤ the rated voltage of DC bus.		
F00.18	Fan control	0: Run at power-on	1	×
		1: Fan working during running		
F00.19	Factory password	0~65535	0	×
F00.20	Inverter rated power	0.2~710.0kW	Model defined	⊖
F00.21	Inverter rated voltage	60~660V	Model defined	⊖
F00.22	Inverter rated current	0.1~1500.0A	Model defined	⊖
F00.23	Software version	0.00~655.35	Model	⊖



## FR500F Series Special Purpose Inverter

			defined	
F00.24	Dealer password	0~65535	0	×
F00.25	Setting operation time	0~65535h(0: Invalid)	0h	×
<b>Group F00: Frequency Command</b>				
F01.00	Frequency source selection	0: Master frequency source	0	×
		1: Auxiliary frequency source		
		2: Master +Auxiliary		
		3: Master - Auxiliary		
		4: MAX{Master, Auxiliary }		
		5: MIN {Master, Auxiliary }		
		6: AI1( Master + Auxiliary)		
F01.01	Master Frequency Command Source	0:Master digital setting (F01.02)	1	×
		1: keypad potentiometer		
		2: Analog input AI1		
		3: Communication		
		4: Multi-reference		
		5: PLC		
		6: Process PID output		
		7: X7/HI pulse input		
		8:AI2		
9:AI3				
F01.02	Digital Setting of Master Frequency	0.00~Fmax	0.00Hz	△
F01.03	Auxiliary Frequency Command Source	0: Auxiliary digital setting (F01.04)	0	×
		1: keypad potentiometer		
		2: Analog input AI1		
		3: Communication		
		4: Multi-reference		
		5: PLC		
		6: Process PID output		
		7: X7/HI pulse input		
		8: Analog input AI2		
9: Analog input AI3				
F01.04	Digital setting of auxiliary frequency	0.00~Fmax	0.00Hz	△
F01.05	Range of auxiliary frequency	0: Relative to maximum frequency	0	×
		1: Relative to master frequency		
F01.06	Coeff of auxiliary frequency	0.0~150.0%	100.0%	△
F01.07	Jog frequency	0.00~Fmax	5.00Hz	△
F01.08	Maximum frequency	20.00~600.00Hz	50.00Hz	×
F01.09	Upper limit frequency	Fdown~Fmax Lower limit frequency~maximum frequency	50.00Hz	×
F01.10	Lower limit frequency	0.00~Fup	0.00Hz	×
F01.11	Operation when command frequency lower than lower limit frequency	0: Run at lower limit frequency	0	×
		1: Run at 0 Hz would be activated after the time delay set by F01.12		
F01.12	Lower limit frequency running time	0.0~6000.0s	60.0s	×
F01.13	Up to this frequency, start frequency compensation	0.00~600.00Hz	50.00Hz	△

FR500F Series Special Purpose Inverter

F01.14	Frequency compensation per 50Hz	0.00~50.00Hz	0.00Hz	△
<b>Group F02: Start/Stop Control</b>				
F02.00	Run command	0: Keypad control (LED off)	0	×
		1: Terminal control (LED on)		
		2: Communication control (LED blinking)		
F02.01	Running direction	0: Forward 1: Reverse	0	△
F02.02	Reverse-proof action	0: Reverse enabled 1: Reverse disabled	0	×
F02.03	Dead time between forward and reverse	0.0~6000.0s	0.0s	×
F02.04	Start mode	Unit's place: Start Mode 0:Start directly 1:Rotational speed track and restart	00000	×
		Ten's place: short-circuit detection function 0:Ungrounded short-circuit detection 1:Grounding short-circuit detection before the first starts 2:Grounding short-circuit detection before each starts		
		Hundred's place: Speed tracking 0:Track from zero speed 1:Track from max frequency		
		Thousand's place: Select if Jog function takes the priority 0:Disable 1:Enable		
		Ten thousand's place: Tracking direction 0: Last direction when stop 1: Positive direction 2: Negative direction 3: Starting direction		
F02.05	Start frequency	0.00~10.00Hz	0.00Hz	×
F02.06	Startup frequency holding time	0.0~100.0s	0.0s	×
F02.07	Startup DC brakin current	0.0~150.0%	0.0%	×
F02.08	DC braking time at start	0.0~100.0s	0.0s	×
F02.09	Speed search current	0.0~180.0%	100.0%	△
F02.10	Sped search decel time	0.0~10.0s	1.0s	×
F02.11	Sped search coefficient	0.01~5.00	0.30	△
F02.12	Stop mode	0: Ramp to stop	0	×
		1: Coast to stop		
F02.13	Initial frequency of stop DC braking	0.01~50.00Hz	2.00Hz	×
F02.14	Stop DC braking current	0.0~150.0%	0.0%	×
F02.15	Waiting time of stop DC braking	0.0~30.0s	0.0s	×
F02.16	Stop DC braking time	0.0~30.0s	0.0s	×
F02.17	Dynamic brake	0: Disabled	0	×
		1: Enabled		

FR500F Series Special Purpose Inverter

		2: Enabled at running		
		3: Enabled at deceleration		
F02.18	Dynamic Brake Voltage	90.0~150.0%	128.0%	×
F02.19	Brake use ratio	5.0~100.0%	100.0%	×
F02.20	0Hz output selection	0: No voltage output	0	×
		1: Voltage output		
F02.21	Auto-start of power-on again	0: Invalid	0	△
		1: Valid		
F02.22	Waiting time between auto-start and power-on again	0.0~10.0s	0.5s	△
<b>Group F03: Accel/Decel Parameters</b>				
F03.00	Accel time 1	0.0~6000.0s	15.0s	△
F03.01	Decel time 1	0.0~6000.0s	15.0s	△
F03.02	Accel time 2	0.0~6000.0s	15.0s	△
F03.03	Decel time 2	0.0~6000.0s	15.0s	△
F03.04	Accel time 3	0.0~6000.0s	15.0s	△
F03.05	Decel time 3	0.0~6000.0s	15.0s	△
F03.06	Accel time 4	0.0~6000.0s	15.0s	△
F03.07	Decel time 4	0.0~6000.0s	15.0s	△
F03.08	Jog accel time	0.0~6000.0s	15.0s	△
F03.09	Jog decel time	0.0~6000.0s	15.0s	△
F03.10	Accel/Decel curve	0: Linear Accel/Decel	0	×
		1: S-curve Accel/Decel		
F03.11	Initial segment time of acceleration of S curve	0.0~6000.0s	0.0s	×
F03.13	Frequency switchover point between acceleration time 1 and acceleration time 2	0.00~Fmax	0.00Hz	×
F03.14	Frequency switchover point between deceleration time 1 and deceleration time 2	0.00~Fmax	0.00Hz	×
F03.15	End segment time of acceleration of S curve	0.0~6000.0s	0.0s	×
F03.16	Initial segment time of deceleration of S curve	0.0~6000.0s	0.0s	×
F03.17	End segment time of deceleration of S curve	0.0~6000.0s	0.0s	×
<b>Group F04 Digital Input</b>				
F04.00	Function of terminal DI1	0: No function	1	×
F04.01	Function of terminal DI2	1: Running forward (FWD)	2	×
F04.02	Function of terminal DI3	2: Running reverse (REV)	7	×
F04.03	Function of terminal DI4	3: Three-wire control	13	×
F04.04	Function of terminal DI5	4: JOG forward	0	×
F04.05	Function of terminal DI6	5: JOG reverse	0	×
F04.06	Function of terminal DI7	6: Coast to stop	0	×
F04.07	Function of terminal AI1	7: Fault reset (RESET)	0	×
F04.08	Function of terminal AI2	8: Running suspended	0	×
F04.09	Function of terminal AI3	9: External fault input	0	×
		10: Terminal UP		
		11: Terminal DOWN		
		12: UP/DOWN (including $\wedge/\vee$ )		

FR500F Series Special Purpose Inverter

		key) adjustment clear		
		13: Multi-step frequency terminal 1		
		14: Multi-step frequency terminal 2		
		15: Multi-step frequency terminal 3		
		16: Multi-step frequency terminal 4		
		17: Accel/Decel time determinant 1		
		18: Accel/Decel time determinant 1		
		19: Accel/Decel disabled(ramp stop not inclusive)		
		20: Switch to auxiliary speed setting		
		21: PLC status reset		
		22: Simple PLC paused		
		23: Simple PLC paused		
		24: PID adjustment direction		
		25: PID integration paused		
		26: PID parameter switch		
		27: Swing frequency pause(output the current frequency)		
		28: Swing frequency reset(output the central frequency)		
		29: Run command switched to keypad contro		
		30: Run command switched to terminal control		
		31: Run command switched to communication control		
		32: Count input		
		33: Count clear		
		34: Length count		
		35: Length clear		
		36: DC brake input command at Stop		
		37: Speed/torque control switch		
		38: No reverse		
		39: No forward		
F04.10	Filtering time of digital input terminal	0.000~1.000s	0.010s	Δ
F04.11	Delay time before terminal DI1 is valid	0.0~300.0s	0.0s	Δ
F04.12	Delay time before terminal DI2 is valid	0.0~300.0s	0.0s	Δ
F04.13	Terminal DI1~DI5 positive/negative logic	DI5、DI4、DI3、DI2、DI1 0: Positive logic(Terminals are on at 0V/off at 24V) 1: Negative Logic (Terminals are off at 0V/on at 24V)	00000	×
F04.14	Terminal DI6~AI3 positive/negative logic	AI3、AI2、AI1、DI7、DI6 0: Positive logic 1: Negative Logic	00000	×
F04.15	FWD/REV terminal control mode	0: Two-wire mode 1 1: Two-wire mode 2 2: Three-wire mode 1 3: Three-wire mode 2	0	×
F04.16	Terminal UP/DOWN frequency adjustment	Unit's place: action when stop 0: Clear	001	×

FR500F Series Special Purpose Inverter

	control	1: Holding Ten's place: action on power loss 0: Clear 1: Holding Hundreds place: integral function 0: No integral function 1: Integral function enabled		
F04.17	Terminal UP/DOWN frequency change step size	0.00~50.00Hz 0.00:Disabled	1.00Hz/ 200ms	△
F04.18	Terminal action selection when power on	0:Level effective 1:Edge trigger +Level effective	0	×
F04.19	Delay time before terminal DI1 is invalid	0.0~300.0s	0.0s	△
F04.20	Delay time before terminal DI2 is invalid	0.0~300.0s	0.0s	△
<b>Group F05 Digital Output</b>				
F05.00	Y1 output function	0: No output	1	×
F05.01	Y2 output function	1: Drive is running	3	
F05.02	Relay 1 output function	2: Fault output 3: Frequency-level detection FDT1 output 4: Frequency-level detection FDT2 output 5: Drive in 0Hz running 1(no output at stop) 6: Drive in 0Hz running 2(output at stop) 7: Upper limit frequency attained 8: Lower limit frequency attained 9: Frequency attained 10: Inverter is ready to work 11: Drive (motor) overloaded alarm 12: Inverter overheat warning 13: Current running time attained 14: Accumulative power-on time attained	2	×
F05.03	Relay 2 output function	15: Consecutive running time attained 16: PLC cycle completed 17: Set count value attained 18: Designated count value attained 19: Length attained 20: Under load alarm 21:Brake output 22: DI1 23: DI2 24:When reach the range of set frequency(FDT1) 26: PID feedback lost 27: operation status (inching without output) 28: communication setting (address 2007h)	11	×
F05.04	Y1 output delay time	0.0~6000.0s	0.0s	△
F05.05	Y2 output delay time	0.0~6000.0s	0.0s	△

## FR500F Series Special Purpose Inverter

F05.06	R1 output delay time	0.0~6000.0s	0.0s	△
F05.07	R2 output delay time	0.0~6000.0s	0.0s	△
F05.08	Enabled state of digital output	Unit's place: Y1	0000	×
		0: Positive logic		
		1: Negative logic		
		Ten's place: Y2 (same as unit's place)		
		Hundred's place: Relay 1 output (same as unit's place) Thousands place: Relay 2 output (same as unit's place)		
F05.09	Detection width of frequency attained	0.00~20.00Hz	5.00Hz	×
F05.10	FDT1 upper bound	0.00~Fmax	30.00Hz	×
F05.11	FDT1 lower bound	0.00~Fmax	30.00Hz	×
F05.12	FDT2 upper bound	0.00~Fmax	30.00Hz	×
F05.13	FDT2 lower bound	0.00~Fmax	30.00Hz	×
F05.14	Consecutive running time	0.0~6000.0Min 0.0:Disabled	0.0Min	×
F05.15	Accumulative power-on time setting	0~65535h 0:Disabled	0h	×
F05.16	Accumulative running time setting	0~65535h 0:Disabled	0h	×
F05.17	Brake control selection	0: Disabled	0	×
		1: Enabled		
F05.18	Brake opened frequency	Closed frequency ~30.00Hz	2.50Hz	×
F05.19	Brake opened current	0.0~200.0%	0.0%	△
F05.20	Brake open waiting time	0.00~10.00s	0.00s	×
F05.21	Brake open operating time	0.00~10.00s	0.50s	×
F05.22	Brake closed frequency	0.00Hz~opened frequency	2.00Hz	×
F05.23	Brake close waiting time	0.00~10.00s	0.00s	×
F05.24	Brake close operating time	0.00~10.00s	0.00s	×
<b>Group F06 Analog and Pulse Input</b>				
F06.00	Minimum input of curve AI1	0.0%~input of inflection point1 of curve AI1	1.0%	△
F06.01	Set value corresponding to minimum input of curve AI1	-100.0~100.0%	0.0%	△
F06.02	Input of inflection point 1 of curve AI1	Minimum input of curve AI1~Input of inflection point 2 of curve AI1	25.0%	△
F06.03	Set value corresponding to input of inflection point 1 of curve AI1	-100.0~100.0%	25.0%	△
F06.04	Input of inflection point 2 of curve AI1	Input of inflection point 1 of curve AI1~Maximum input of curve AI1	75.0%	△
F06.05	Set value corresponding to input of inflection point 2 of curve AI1	-100.0~100.0%	75.0%	△
F06.06	Maximum input of curve AI1	Input of inflection point 2 of curve AI1~100.0%	100.0%	△
F06.07	Set value corresponding to maximum input of curve AI1	-100.0~100.0%	100.0%	△
F06.08	Minimum input of curve AI2	0.0%~input of inflection point1 of curve AI2	1.0%	△

## FR500F Series Special Purpose Inverter

F06.09	Set value corresponding to minimum input of curve AI2	-100.0~100.0%	0.0%	△
F06.10	Input of inflection point 1 of curve AI2	Minimum input of curve AI1~Input of inflection point 2 of curve AI2	25.0%	△
F06.11	Set value corresponding to input of inflection point 1 of curve AI2	-100.0~100.0%	25.0%	△
F06.12	Input of inflection point 2 of curve AI2	Input of inflection point 1 of curve AI2~Maximum input of curve AI2	75.0%	△
F06.13	Set value corresponding to input of inflection point 2 of curve AI2	-100.0~100.0%	75.0%	△
F06.14	Maximum input of curve AI2	Input of inflection point A of curve AI2~100.0%	100.0%	△
F06.15	Set value corresponding to maximum input of curve AI2	-100.0~100.0%	100.0%	△
F06.16	Minimum input of curve AI3	0.0%~input of inflection point1 of curve AI3	0.0%	△
F06.17	Set value corresponding to minimum input of curve AI3	-100.0~100.0%	0.0%	△
F06.18	Input of inflection point 1 of curve AI3	Minimum input of curve AI1~Input of inflection point 2 of curve AI3	25.0%	△
F06.19	Set value corresponding to input of inflection point 1 of curve AI3	-100.0~100.0%	25.0%	△
F06.20	Input of inflection point 2 of curve AI3	Input of inflection point 1 of curve AI3~Maximum input of curve AI3	75.0%	△
F06.21	Set value corresponding to input of inflection point 2 of curve AI3	-100.0~100.0%	75.0%	△
F06.22	Maximum input of curve AI3	Input of inflection point A of curve AI3~100.0%	100.0%	△
F06.23	Set value corresponding to maximum input of curve AI3	-100.0~100.0%	100.0%	△
F06.24	Minimum input of curve keypad potentiometer	0.0~Maximum input of curve keypad potentiometer	0.1%	△
F06.25	Set value corresponding to minimum input of curve keypad potentiometer	-100.0~100.0%	0.0%	△
F06.26	Maximum input of curve keypad potentiometer	Minimum input of curve keypad potentiometer~100.0	99.9%	△
F06.27	Set value corresponding to maximum input of curve keypad potentiometer	-100.0~100.0%	100.0%	△
F06.28	AI1 terminal filtering time	0.000~10.000s	0.100s	△
F06.29	AI2 terminal filtering time	0.000~10.000s	0.100s	△
F06.30	AI3 terminal filtering time	0.000~10.000s	0.100s	△
F06.31	Keypad potentiometer filtering time	0.000~10.000s	0.100s	△
F06.32	Minimum input of curve HI	0.00 kHz~Maximum input of curve	0.00kHz	△

# FR500F Series Special Purpose Inverter

		HI		
F06.33	Set value corresponding to minimum input of curve HI	-100.0~100.0%	0.0%	△
F06.34	Maximum input of curve HI	Minimum input of curve HI~100.00kHz	50.00kHz	△
F06.35	Set value corresponding to maximum input of curve HI	-100.0~100.0%	100.0%	△
F06.36	HI terminal filtering time	0.000~10.000s	0.100s	△
<b>Group F07 Analog and Pulse Output</b>				
F07.00	AO1 output function	0: No output	1	×
F07.01	AO2 output function	1: Output frequency	2	×
F07.02	Y2/HO output function (when used as HO)	2: Command frequency 3: Output current 4: Output voltage 5: Output power 6: Bus voltage 7: +10V 8: keypad potentiometer 9: AI1 10: AI2 11: AI3 12: HI 13: Output torque 14: Ao communication given 1 15: Ao communication given 2	1	×
F07.03	AO1 offset	-100.0~100.0%	0.0%	△
F07.04	AO1 gain	-2.000~2.000	1.000	△
F07.05	AO1 filtering time	0.000~10.000s	0.000s	△
F07.06	AO2 offset	-100.0~100.0%	0.00%	△
F07.07	AO2 gain	-2.000~2.000	1.000	△
F07.08	AO2 filtering time	0.000~10.000s	0.000s	△
F07.09	HO maximum output pulse frequency	0.01~100.00kHz	50.00kHz	△
F07.10	HO output filtering time	0.000~10.000s	0.010s	△
<b>Group F08 Parameters of Motor 1</b>				
F08.00	Motor 1 type selection	0: Three phase asynchronous motors 1: Reserved 2: Single phase asynchronous motors (Remove capacity) 3: Single phase asynchronous motors (No need to remove capacity)	0	×
F08.01	Power rating of motor 1	0.1~1000.0kW	Model defined	×
F08.02	Rated voltage of motor 1	60~660V	Model defined	×
F08.03	Rated current of motor 1	0.1~1500.0A	Model defined	×
F08.04	Rated frequency of motor 1	20.00~Fmax	Model defined	×
F08.05	Rated speed of motor 1	1~30000	Model defined	×
F08.08	Stator resistance R1 of async motor 1	0.001~65.535Ω	Model defined	×



FR500F Series Special Purpose Inverter

F08.09	Rotor resistance R2 of async motor 1	0.001~65.535Ω	Model defined	×
F08.10	Leakage inductance L1 of async motor 1	0.01~655.35mH	Model defined	×
F08.11	Mutual inductance L2 of asynchronous motor 1	0.1~6553.5mH	Model defined	×
F08.12	No-load current of async motor 1	0.1~1500.0A	Model defined	×
F08.13	Field weakening coeff 1 of async motor 1	0.0~100.0	87%	×
F08.14	Field weakening coeff 2 of async motor 1	0.0~100.0	75%	×
F08.15	Field weakening coeff 3 of async motor 1	0.0~100.0	70%	×
F08.30	Autotuning of motor 1	0: No autotuning	0	×
		1: Static autotuning of motor		
		2: Rotary autotuning of motor		
<b>Group F09 V/f Control Parameters of Motor 1</b>				
F09.00	V/f curve setting	0: Linear V/f	0	×
		1: Multi-stage V/f		
		2: 1.2nd power V/F		
		3: 1.4th power V/F		
		4: 1.6th power V/F		
		5: 1.8th power V/F		
		6: 2.0nd power V/F		
		7: V/F complete separation		
		8: V/F half separation		
		9: 1.2 power inverse curve V/F		
		10:1.4 power inverse curve V/F		
		11:1.6 power inverse curve V/F		
		12:1.8 power inverse curve V/F		
13:2.0 power inverse curve V/F				
F09.01	Torque boost	0.1%~30.0% 0.0% (fixed torque boost)	0.0%	Δ
F09.02	Cut-off frequency of torque boost	0.00~Fmax	50.00Hz	Δ
F09.03	Multi-point V/F frequency 1(F1)	0.00~F09.05	0.00Hz	Δ
F09.04	Multi-point V/F voltage 1 (V1)	0.0~100.0	0.0%	Δ
F09.05	Multi-point V/F frequency 2(F2)	F09.03~F09.05	0.00Hz	Δ
F09.06	Multi-point V/F voltage 2 (V2)	0.0~100.0	0.0%	Δ
F09.07	Multi-point V/F frequency 3(F3)	F09.05~F09.09	0.00Hz	Δ
F09.08	Multi-point V/F voltage 3 (V3)	0.0~100.0	0.0%	Δ
F09.09	Multi-point V/F frequency 4(F4)	F09.07~rated motor frequency	50.00Hz	Δ
F09.10	Multi-point V/F voltage 4 (V4)	0.0~100.0 Ue=100.0%	100.0%	Δ
F09.11	V/F slip compensation gain	0.0~300.0%	0.0%	Δ
F09.12	Stator voltagedrop compensation gain	0.0~200.0%	100.0%	Δ

# FR500F Series Special Purpose Inverter

F09.13	Excitation boost gain	0.0~200.0%	100.0%	△
F09.14	Oscillation Suppression	0.0~300.0%	Model defined	△
F09.15	Voltage source for V/F separation	0: Digital setting (F09.16)	0	×
		1:keypad potentiometer		
		2:A11		
		3: Multi-reference		
		4: Pulse setting ( DI7/HI )		
		5: PID		
		6:A12		
F09.16	Voltage digital setting for V/F separation	0 V to rated motor voltage	0.0%	△
F09.17	Voltage rise time of V/F separation	0.0~6000.0s It indicates the time for the voltage rising from 0 V to rated Motor voltage.	0.1s	△
<b>Group F10 Vector Control Parameters of Motor 1</b>				
F10.00	Speed/torque control	0: speed control	0	×
		1: torque control		
F10.01	ASR low-speed proportional gain Kp1	0.0~100.0	30.0	△
F10.02	ASR low-speed integration time T11	0.01~10.00s	0.50s	△
F10.03	ASR switching frequency 1	0.00~F10.06	5.00Hz	△
F10.04	ASR high-speed proportional gain Kp2	1~100.0	10.0	△
F10.05	ASR high-speed integration time T12	0.01~10.00s	0.100s	△
F10.06	ASR switching frequency 2	F10.03~Fmax	10.00Hz	△
F10.07	ASR input filtering time	0.0~500.0ms	0.3ms	△
F10.08	ASR output filtering time	0.0~500.0ms	0.0ms	△
F10.09	Vector control slip gain	50~200%	100%	△
F10.10	Digital setting of torque upper limit in speed control mode	80.0~200.0%	165.0%	×
F10.11	Excitation adjustment proportional gain Kp1	0.00~10.00	0.50	△
F10.12	Excitation adjustment integral gain Ti1	0.0~3000.0ms	10.0ms	△
F10.13	Torque adjustment proportional gain Kp2	0.00~10.00	0.50	△
F10.14	Torque adjustment integral gain Ti2	0.0~3000.0ms	10.0ms	△
F10.15	reserved			
F10.16	Torque setting source under torque control	0: Set by F10.17	0	×
		1:Keypad potentiometer		
		2:A11		
		3:A12		
		4:A13		
		5: Pulse setting ( DI7/HI )		
F10.17	Digital setting of torque	-200.0~200.0%	150.0%	△
F10.18	Forward speed limited	0.0~Fmax	50.00Hz	△

FR500F Series Special Purpose Inverter

	value under torque control			
F10.19	Reverse speed limited value under torque contro	0.00~ Fmax	50.00Hz	Δ
F10.20	Set torque accel time	0.0~6000.0s	0.0s	Δ
F10.21	Set torque decel time	0.0~6000.0s	0.0s	Δ
F10.22	Static friction torque compensation	0.0~100.0%	5.00%	Δ
F10.23	Static friction frequency range	0.00~20.00Hz	1.00Hz	Δ
F10.24	Sliding friction torque compensation	0.0~100.0%	1.0%	Δ
F10.25	SVC optimization mode	0: Optimization mode 0 1: Optimization mode 1 2: Optimization mode 2	1	×
F10.26	Max Frequency source under torque control	0: Set by F10.18 & F10.19 1:Keypad potentiometer 2:AI1 3:AI2 4:AI3 5: Pulse setting ( DI7/HI )	0	×
<b>Group F11 Protection Parameters</b>				
F11.00	Current limit control	0: Current limit disabled 1: Current limit mode 1 2: Current limit mode 2	2	×
F11.01	Current limit	100.0~200.0%	150.0%	×
F11.02	Frequency decreasing time(limit current in constant speed operation)	0.0~6000.0s	5.0s	Δ
F11.03	Current limit mode 2 proportion gain	0.1~100.0%	3.0%	Δ
F11.04	Current limit mode 2 integral time	0.000~1.000s	0.010s	Δ
F11.05	Overvoltage Stall Control	0: Overvoltage stall disabled 1: Overvoltage stall mode 1 2: Overvoltage stall mode 2	1	×
F11.06	Overvoltage Stall Voltage	120.0~150.0%	130.0%	×
F11.07	Overvoltage Stall Mode 2 Proportion Gain	0.1~100.0%	3.0%	Δ
F11.08	Overvoltage stall mode 2 frequency limit	0.00~50.00Hz	5.00Hz	×
F11.10	Protection action 1	Unit's place: Bus undervoltage 0: Fault reported and coast to stop 1: Stop according to the stop mode 2: Fault reported but continue to run 3: Fault protection disabled Ten's place: Power input phase Loss (Err09)(Same as unit's place ) Hundred's place: Power output phase loss(Err10)(Same as unit's place ) Thousand's place: Motor overload (Err11)(Same as unit's place ) Ten thousand's place: Inverter	00330	×

FR500F Series Special Purpose Inverter

		overload(Err11)(Same as unit's place )		
F11.11	Protection action 2	External equipment fault ( Err13)	00000	×
		0: Fault reported and coast to stop		
		1: Stop according to the stop mode		
		2: Fault reported but continue to run		
		Ten's place: EEPROM read/write fault (Err15) (Same as unit's place)		
		Hundred's place: Communication overtime error (Err18) (Same as unit's place)		
		Thousand's place: PID feedback loss (Err19) (Same as unit's place)		
Ten thousand's place: Continuous running time reached (Err20) (Same as unit's place)				
F11.12	Protection action 3	Unit's place: Module temperature detection disconnection ( Err24)	00030	×
		0: Fault reported and coast to stop		
		1: Stop according to the stop mode		
		2: Fault reported but continue to run		
Ten's place: Load becoming 0 (Err25) (Same as unit's place)				
F11.14	Frequency selection for continuing to run upon fault	0: Current running frequency	0	×
		1: Set frequency		
		2: Frequency upper limit		
		3: Frequency lower limit		
		4: Backup frequency upon abnormality		
F11.15	Backup frequency upon abnormality	0.00~Fmax	0.00Hz	×
F11.17	Motor overload protection time	30.0~300.0s	60.0s	×
F11.18	Overload alarm	Unit's place: detection option: 0: Always detect 1: Detect at constant speed only	00	×
		Ten's place : compared object 0: Rated current of motor 1: Rated current of drive		
		Hundred's place: Fault reported 0:No fault reported 1:Fault reported		
		Thousand's place: whether to decelerate or not when overload alarm 0: No deceleration 1: Deceleration		
		Ten thousand's place: Overload level given mode 0:F11.19 set 1:VP*F11.19 2:AI1*F11.19 3:AI2*F11.19 4:AI3*F11.19		

FR500F Series Special Purpose Inverter

F11.19	Overload alarm threshold	20.0~200.0%	130.0%	×
F11.20	Overload alarm activated time that exceeding threshold	0.1~60.0s	5.0s	×
F11.21	Inverter overheat warning threshold	50~overheat Temperature	Model defined	×
F11.22	Detection level of power loss	5.0~100.0%	20.0%	×
F11.23	Detection time of power loss	0.1~60.0s	5.0s	×
F11.24	Action selection at instantaneous power failure	0: Disabled	1	×
		1: Enabled		
F11.25	Decel time at instantaneous power failure	0.0~6000.0s	5.0s	△
F11.26	Rapid current limit	0: Disabled	0	×
		1: Enabled		
F11.27	Times of automatic reset	0~20	0	×
F11.28	Interval of automatic reset	0.1~100.0s	1.0s	×
F11.29	DO action during fault auto reset	0: Not act	0	×
		1: Act		
F11.30	Instantaneous power off bus voltage	60.0%~Recovery voltage	80.0%	△
F11.31	Instantaneous power off recovery voltage	Power off voltage~100.0%	85.0%	△
F11.32	Instantaneous power off voltage detection time	0.01~10.00s	0.10s	△
F11.33	Instantaneous power off Kp	0.1~100.0%	40.0%	△
F11.34	Instantaneous power off integration time Ti	0.00~10.00s (0.00:Integration invalid)	0.10s	△
F11.35	Motor temperature sensor type	0:None 1:PT100 2:PT1000 3:KTY84	0	×
F11.36	Zero drift value of motor temperature sensor	-100~100℃	0	△
F11.37	Reserved			
F11.38	Motor temperature warning action threshold	0~200℃	90℃	△
F11.39	Motor temperature protection action threshold	0~200℃	110℃	△
<b>Group F12: Multi-Reference and Simple PLC Function</b>				
F12.00	Reference 0	-100.0~100.0%	0.0%	△
F12.01	Reference 1	-100.0~100.0%	0.0%	△
F12.02	Reference 2	-100.0~100.0%	0.0%	△
F12.03	Reference 3	-100.0~100.0%	0.0%	△
F12.04	Reference 4	-100.0~100.0%	0.0%	△
F12.05	Reference 5	-100.0~100.0%	0.0%	△
F12.06	Reference 6	-100.0~100.0%	0.0%	△
F12.07	Reference 7	-100.0~100.0%	0.0%	△

FR500F Series Special Purpose Inverter

F12.08	Reference 8	-100.0~100.0%	0.0%	△
F12.09	Reference 9	-100.0~100.0%	0.0%	△
F12.10	Reference 10	-100.0~100.0%	0.0%	△
F12.11	Reference 11	-100.0~100.0%	0.0%	△
F12.12	Reference 12	-100.0~100.0%	0.0%	△
F12.13	Reference 13	-100.0~100.0%	0.0%	△
F12.14	Reference 14	-100.0~100.0%	0.0%	△
F12.15	Reference 15	-100.0~100.0%	0.0%	△
F12.16	Reference 0 source	0: Digital setting (F12.00)	0	×
		1:keypad potentiometer		
		2:AI1		
		3: Process PID output		
		4: X7/HI pulse input		
		5:AI2		
F12.17	Running mode of simple PLC	6:AI3	0000	×
		Unit's place: PLC running mode		
		0: Stop after a single cycle		
		1: Continue to run with the last frequency after a single cycle		
		2: Repeat cycles		
		Ten's place: started mode		
		0: Continue to run from the step of stop (or fault)		
		1: Run from the first step "multi-step frequency 0"		
		2: Run from the eighth step "multi-step frequency 8"		
		3: Run from the fifteenth step "multi-step frequency 15"		
		Hundreds place:power loss memory		
		0: Memory disabled on power loss		
		1: Memory enabled on power loss		
Thousands place: unit of simple PLC running time				
0: Second (s)				
1: Minute (min)				
F12.18	Running time of step 0	0.0~6000.0s(h)	0.0s(h)	△
F12.19	Running time of step 1	0.0~6000.0s(h)	0.0s(h)	△
F12.20	Running time of step 2	0.0~6000.0s(h)	0.0s(h)	△
F12.21	Running time of step 3	0.0~6000.0s(h)	0.0s(h)	△
F12.22	Running time of step 4	0.0~6000.0s(h)	0.0s(h)	△
F12.23	Running time of step 5	0.0~6000.0s(h)	0.0s(h)	△
F12.24	Running time of step 6	0.0~6000.0s(h)	0.0s(h)	△
F12.25	Running time of step 7	0.0~6000.0s(h)	0.0s(h)	△
F12.26	Running time of step 8	0.0~6000.0s(h)	0.0s(h)	△
F12.27	Running time of step 9	0.0~6000.0s(h)	0.0s(h)	△
F12.28	Running time of step 10	0.0~6000.0s(h)	0.0s(h)	△
F12.29	Running time of step 11	0.0~6000.0s(h)	0.0s(h)	△
F12.30	Running time of step 12	0.0~6000.0s(h)	0.0s(h)	△
F12.31	Running time of step 13	0.0~6000.0s(h)	0.0s(h)	△
F12.32	Running time of step 14	0.0~6000.0s(h)	0.0s(h)	△
F12.33	Running time of step 15	0.0~6000.0s(h)	0.0s(h)	△

## FR500F Series Special Purpose Inverter

F12.34	Acceleration/deceleration time of simple PLC reference 0	0~3	0	△
F12.35	Acceleration/deceleration time of simple PLC reference 1	0~3	0	△
F12.36	Acceleration/deceleration time of simple PLC reference 2	0~3	0	△
F12.37	Acceleration/deceleration time of simple PLC reference 3	0~3	0	△
F12.38	Acceleration/deceleration time of simple PLC reference 4	0~3	0	△
F12.39	Acceleration/deceleration time of simple PLC reference 5	0~3	0	△
F12.40	Acceleration/deceleration time of simple PLC reference 6	0~3	0	△
F12.41	Acceleration/deceleration time of simple PLC reference 7	0~3	0	△
F12.42	Acceleration/deceleration time of simple PLC reference 8	0~3	0	△
F12.43	Acceleration/deceleration time of simple PLC reference 9	0~3	0	△
F12.44	Acceleration/deceleration time of simple PLC reference 10	0~3	0	△
F12.45	Acceleration/deceleration time of simple PLC reference 11	0~3	0	△
F12.46	Acceleration/deceleration time of simple PLC reference 12	0~3	0	△
F12.47	Acceleration/deceleration time of simple PLC reference 13	0~3	0	△
F12.48	Acceleration/deceleration time of simple PLC reference 14	0~3	0	△
F12.49	Acceleration/deceleration time of simple PLC reference 15	0~3	0	△
F12.50	UP/DOWN function selection of Multi-reference	Unit's place: Action selection when power off 0:Zero clearing when power off 1:Hold when power off Ten's place: select if it can be reduced to negative 0:Disable 1:Enable	00	×
F12.51	UP/DOWN speed of Multi-reference	0.0~100.0% (0.0%Invalid)	0.0%	△

FR500F Series Special Purpose Inverter

Group F13 Process PID				
F13.00	PID setting	0: F13.01 digital setting	0	×
		1: keypad potentiometer		
		2: AI1		
		3: Communication		
		4: Multi-Reference		
		5: DI7/HI pulse input		
		6: AI2		
F13.01	PID digital setting	0.0~100.0%	50.0%	△
F13.02	PID feedback	0: AI1	0	×
		1: AI2		
		2: Communication		
		3: AI1+AI2		
		4: AI1-AI2		
		5: Max{AI1, AI2}		
		6: Min{AI1, AI2}		
		7: DI7/HI pulse input		
F13.03	PID setting feedback range	0~60000	1000	△
F13.04	PID action direction	0: Forward action	0	×
		1: Reverse action		
F13.05	Filtering time of PID setting	0.000~10.000s	0.000s	△
F13.06	Filtering time of PID feedback	0.000~10.000s	0.000s	△
F13.07	Filtering time of PID output	0.000~10.000s	0.000s	△
F13.08	Proportional gain Kp1	0.0~100.0	1.0	△
F13.09	Integration time Ti1	0.01~10.00s	0.10s	△
F13.10	Differential time Td1	0.000~10.000s	0.000s	△
F13.11	Proportional gain Kp2	0.0~100.0	1.0	△
F13.12	Integration time Ti2	0.01~10.00s	0.10s	△
F13.13	Differential time Td2	0.000~10.000s	0.000s	△
F13.14	PID parameter switch	0: No switch, determined by parameters Kp1, Ti1 and Td1	0	×
		1: Auto switch on the basis of input offset		
		2: Switched by terminal		
F13.15	PID parameter switchover deviation 1	0.0~100.0%	20.0%	×
F13.16	PID parameter switchover deviation 2	0.0~100.0%	80.0%	×
F13.17	PID offset limit	0.0~100.0%	1.0%	×
F13.18	PID integral property	Unit's place (Whether to stop integral operation when the output reaches the limit)	00	×
		0: Continue integral operation		
		1: Stop integral operation		
		Ten's digit (Integral separated)		
		0: Invalid		
1: Valid				
F13.19	PID differential limit	0.0~100.0%	0.5%	×
F13.20	PID initial value	0.0~100.0%	0.0%	×



## FR500F Series Special Purpose Inverter

F13.21	Holding time of PID initial value	0.0~6000.0s	0.0s	×
F13.22	PID output frequency upper limit	PID output frequency lower limit~100.0% (100.0% corresponds to maximum frequency )	100.0%	×
F13.23	PID output frequency lower limit	-100.0%~PID output frequency lower limit	0.0%	×
F13.24	Low limit of PID feedback loss	0.1~100.0% 0.0%: Not judging feedback loss	0.0%	×
F13.25	Detection time for low limit of PID feedback loss	0.0~30.0s	1.0s	×
F13.26	PID operation at stop	Unit's place: operation mode 0: No PID operation at stop 1: PID operation at stop	0000	×
		Ten's place: PID output limit 0: Not limit 1: limit		
		Hundred's place: PID UP/DOWN given 0: Zero-clearing when power off 1: Remain when power off		
		Thousand's place: PID feedback loss detection method 0: No detection when stop 1: Do detection when stop		
		Ten thousand's place: Action when PID feedback loss 0: Report Err 1: Ramp to stop		
F13.27	PID UP/DOWN speed	0.0~100.0% (0.0%invalid)	0.0%	△
F13.28	Upper limit of PID feedback loss	0.1~100.0% 0.0%: Not judging feedback loss	100.0%	×
F13.29	Detection time for upper limit of PID feedback loss	0.0~30.0s	1.0s	×
F13.30	PID upper limit source	0:F13.22 1:F13.22*VP 2:F13.22*AI1 3:F13.22*AI2 4:F13.22*HI 5:F13.22*AI3	0	×
F13.31	PID lower limit source	0:F13.23 1:F13.23*VP 2:F13.23*AI1 3:F13.23*AI2 4:F13.23*HI 5:F13.23*AI3	0	×
<b>Group F14: Swing Frequency, Fixed Length , Wakeup and Count</b>				
F14.00	Swing frequency setting mode	0: Relative to the setting frequency	0	×
		1: Relative to the maximum frequency		
F14.01	Swing frequency amplitude	0.0~100.0%	0.0%	△
F14.02	Jump frequency amplitude	0.0~50.0%	0.0%	△

# FR500F Series Special Purpose Inverter

F14.03	Rising Time of Swing frequency	0.0~6000.0s	5.0s	Δ
F14.04	Dropping Time of Swing frequency	0.0~6000.0s	5.0s	Δ
F14.05	Set length	0m~65535m	1000m	×
F14.06	Number of pulses per meter	0.1~6553.5	100.0	×
F14.07	Command when the length attained	Unit's place: stop when the length reaches 0: Not stop 1: Stop	00	×
		Ten's place: length calculation method 0: pulse by pulse 1: Reference maximum frequency 2: Refer to AI1 channel 3: Refer to AI2 channel 4: Refer to AI3 channel		
F14.08	Set count value	1~65535	1000	×
F14.09	Designated count value	1~65535	1000	×
F14.10	Wakeup frequency	Dormant frequency (F14.12)~Fmax	0.00Hz	Δ
F14.11	Wakeup delay time	0.0~6000.0s	0.0s	Δ
F14.12	Dormant frequency	0.00~Wakeup frequency	0.00Hz	Δ
F14.13	Dormant delay time	0.0~6000.0s	0.0s	Δ
F14.14	Wake up mode selection	0:Frequency	0	×
		1:Pressure		
F14.15	Dormancy mode selection	0:Frequency	0	×
		1:Pressure		
F14.16	Voltage feedback source	Unit's place: pressure feedback channel 0:AI1 1:AI2 2:DI7/HI pulse input 3:AI3	00	×
		Ten's place: pressure dormancy mode 0: Dormancy on high pressure, wake up on low pressure. 1: Dormancy on low pressure, wakeup on high pressure.		
F14.17	Wake up pressure	0.0%~Dormancy pressure	10.0%	Δ
F14.18	Dormancy pressure	Wake up pressure~100.0%	50.0%	Δ
<b>Group F15: Communication Parameters</b>				
F15.00	Baud rate	0:4800bps	1	×
		1:9600bps		
		2:19200bps		
		3:38400bps		
		4:57600bps		
		5:115200bps		
F15.01	Data format	No check, data format (1-8-N-2) for RTU	0	×
		1: Even parity check, data format (1-8-E-1) for RTU		
		2: Odd Parity check, data format (1-8-O-1) for RTU		

## FR500F Series Special Purpose Inverter

		3: No check, data format(1-8-N-1) for RTU		
F15.02	Local address	1~247 0: Broadcast address	1	×
F15.03	Communication timeout	0.0~60.0s	0.0s	×
F15.04	Response time delay	0~200ms	1ms	×
F15.05	Master-slave Communication Mode	0:The inverter is the slave	0	×
		1:The inverter is the master		
F15.06	The Master Communication Sending Data	0: Set frequency	0	×
		1: Current running frequency		
F15.07	Message return when communication error	0: No return		
		1: Return		
F15.08	U group return value	0:Positive and negative	0	△
		1:Absolute value		
<b>Group F16 Keys and Display of Keypad Parameters</b>				
F16.00	MF.K key setting	0: No function	1	×
		1: Jog		
		2: Forward/reverse switchover		
		3: Run command sources shifted		
F16.01	Function of STOP/RST key	0: STOP/RST key valid only when under keypad control	1	×
		1: STOP/RST key valid under any run command source		
F16.02	Keys locked option	0: Not locked	0	×
		1: Full locked		
		2: Keys locked other than RUN, STOP/RST		
		3: Keys locked other than STOP/RST		
		4: Keys locked other than >>		
F16.03	LED displayed parameters setting 1 on running status	0~99(correspond U00.00~U00.99)	0	△
F16.04	LED displayed parameters setting 2 on running status	0~99(correspond U00.00~U00.99)	6	△
F16.05	LED displayed parameters setting 3 on running status	0~99(correspond U00.00~U00.99)	3	△
F16.06	LED displayed parameters setting 4 on running status	0~99(correspond U00.00~U00.99)	2	△
F16.07	LED displayed parameters setting 1 on stop status	0~99(correspond U00.00~U00.99)	1	△
F16.08	LED displayed parameters setting 2 on stop status	0~99(correspond U00.00~U00.99)	6	△
F16.09	LED displayed parameters setting 3 on stop status	0~99(correspond U00.00~U00.99)	15	△
F16.10	LED displayed parameters setting 4 on stop status	0~99(correspond U00.00~U00.99)	16	△
F16.11	Coefficient for speed display	0.00~100.00	1.00	△
F16.12	Coefficient for power display	0.0~300.0%	100.0%	△
F16.13	Display error between U00.00 and U00.01	0.00Hz~5.00Hz	0.1Hz	△
<b>Group F17 User-defined Display Parameters</b>				

## FR500F Series Special Purpose Inverter

F17.00	User-defined Display Parameter 0	00.00~49.99	00.03	△
F17.01	User-defined Display Parameter 1	00.00~49.99	01.01	△
F17.02	User-defined Display Parameter 2	00.00~49.99	01.02	△
F17.03	User-defined Display Parameter 3	00.00~49.99	01.08	△
F17.04	User-defined Display Parameter 4	00.00~49.99	01.09	△
F17.05	User-defined Display Parameter 5	00.00~49.99	02.00	△
F17.06	User-defined Display Parameter 6	00.00~49.99	02.01	△
F17.07	User-defined Display Parameter 7	00.00~49.99	02.12	△
F17.08	User-defined Display Parameter 8	00.00~49.99	03.00	△
F17.09	User-defined Display Parameter 9	00.00~49.99	03.01	△
F17.10	User-defined Display Parameter 10	00.00~49.99	04.00	△
F17.11	User-defined Display Parameter 11	00.00~49.99	04.01	△
F17.12	User-defined Display Parameter 12	00.00~49.99	04.02	△
F17.13	User-defined Display Parameter 13	00.00~49.99	04.03	△
F17.14	User-defined Display Parameter 14	00.00~49.99	05.02	△
F17.15	User-defined Display Parameter 15	00.00~49.99	08.01	△
F17.16	User-defined Display Parameter 16	00.00~49.99	08.02	△
F17.17	User-defined Display Parameter 17	00.00~49.99	08.03	△
F17.18	User-defined Display Parameter 18	00.00~49.99	08.04	△
F17.19	User-defined Display Parameter 19	00.00~49.99	08.05	△
F17.20	User-defined Display Parameter 20	00.00~49.99	08.30	△
F17.21	User-defined Display Parameter 21	00.00~49.99	11.10	△
F17.22	User-defined Display Parameter 22	00.00~49.99	13.00	△
F17.23	User-defined Display Parameter 23	00.00~49.99	13.01	△
F17.24	User-defined Display Parameter 24	00.00~49.99	13.02	△
F17.25	User-defined Display Parameter 25	00.00~49.99	13.08	△
F17.26	User-defined Display Parameter 26	00.00~49.99	13.09	△
F17.27	User-defined Display Parameter 27	00.00~49.99	00.00	△
F17.28	User-defined Display	00.00~49.99	00.00	△

## FR500F Series Special Purpose Inverter

	Parameter 28			
F17.29	User-defined Display Parameter 29	00.00~49.99	00.00	Δ
<b>Group U00 Status Monitoring</b>				
U00.00	Running frequency	0.00~Fup	0.00Hz	⊙
U00.01	Set frequency	0.00~Fmax	0.00Hz	⊙
U00.02	Output voltage	0~660V	0.0V	⊙
U00.03	Output current	0.0~3000.0A	0.0A	⊙
U00.04	Output power	-3000.0~3000.0kW	0.0kW	⊙
U00.05	Estimated Motor Speed	0~60000rpm	0rpm	⊙
U00.06	Bus voltage	0~1200V	0V	⊙
U00.07	Synchronous Frequency	0.00~Fup	0.00Hz	⊙
U00.08	PLC step	1~15	1	⊙
U00.09	Program Operation Time	0.0~6000.0s(h)	0.0s(h)	⊙
U00.10	PID set	0~60000	0	⊙
U00.11	PID feedback	0~60000	0	⊙
U00.12	Status of DI1~DI5 digital input terminal	DI5 DI4 DI3 DI2 DI1	00000	⊙
U00.13	Status of DI6~DI7 digital input terminal	DI7 DI6	00	⊙
U00.14	Status of digital output terminal	R2 R1 Y2 Y1	0000	⊙
U00.15	AI1 input	0.0~100.0%	0.0%	⊙
U00.16	AI2 input	0.0~100.0%	0.0%	⊙
U00.17	AI3 input	-100.0~100.0%	0.0%	⊙
U00.18	Keypad potentiometer input	0.0~100.0%	0.0%	⊙
U00.19	HI input	0.00~100.00kHz	0.00kHz	⊙
U00.20	AO1 output	0.0~100.0%	0.0%	⊙
U00.21	AO2 output	0.0~100.0%	0.0%	⊙
U00.22	HO output	0.00~100.00kHz	0.00kHz	⊙
U00.23	Temperature of inverter	-40.0℃~120.0℃	0.0℃	⊙
U00.24	Accumulative power-on time	0~65535min	0min	⊙
U00.25	Accumulative running time	0~6553.5min	0.0min	⊙
U00.26	Cumulative power-on time	0~65535h	0h	⊙
U00.27	Cumulative running time	0~65535h	0h	⊙
U00.28	Count value	0~65535	0	⊙
U00.29	Length value	0~65535m	0m	⊙
U00.30	Linear speed	0~65535m/min	0m/Min	
U00.31	Output torque	0.0~300.0%	0.0%	⊙
U00.32	PTC motor temperature detection	-40℃~200℃	0℃	⊙
U00.33	Speed that detected by encoder	0~60000rpm	0rpm	⊙
U00.34	Monitoring of encoder line number	0~65535	0	⊙
U00.35	Power consumption	0~65535kWh	0kWh	⊙
<b>Group U01 Fault Record</b>				
U01.00	Code of the latest fault	0: No fault	0	⊙
		Err01:Accel overcurrent		

FR500F Series Special Purpose Inverter

		Err02:Decel overcurrent		
		Err03:Constant-speed overcurrent		
		Err04:Accel overvoltage		
		Err05:Decel overvoltage		
		Err06:Constant-speed overvoltage		
		Err07:Bus undervoltage		
		Err08:Short circuit		
		Err09:Power input phase loss		
		Err10:Power output phase loss		
		Err11:Motor overload		
		Err12:Inverter overload		
		Err13:External equipment fault		
		Err14:Module overheat		
		Err15:EEPROM read/write fault		
		Err16:Motor auto-tuning cancelled		
		Err17:Motor auto-tuning fault		
		Err18:Communication overtime error		
		Err19:PID feedback loss		
		Err20:Continuous running time reached		
		Err21:Parameter upload fault		
		Err22:Parameter download fault		
		Err23:Braking unit fault		
		Err24:Module temperature detection disconnection		
		Err25: Load becoming 0		
		Err26:With-wave current limit fault		
		Err27:Inverter soft-start relay is off		
		Err28:Software version compatibility fault		
		Err29:Instantaneous overcurrent		
		Err30:Instantaneous overvoltage		
		Err39:PTC motor temperature too high		
		Err40:Setting operation time ends		
		Err41: Overload warning		
U01.01	Running frequency when the latest fault occurred	0.00~Fup	0.00Hz	⊙
U01.02	Output current when the latest fault occurred	0.0~3000.0A	0.0A	⊙
U01.03	Bus voltage when the latest fault occurred	0~1200V	0V	⊙
U01.04	Cumulative running time when the latest fault occurred	0~65535h	0h	⊙
U01.05	Code of previous fault	Same as U01.00	0	⊙
U01.06	Running frequency when previous fault occurred	0.00~Fup	0.00Hz	⊙
U01.07	Output current when previous fault occurred	0.0~3000.0A	0.0A	⊙
U01.08	Bus voltage when previous fault occurred	0~1200V	0V	⊙
U01.09	Cumulative running time	0~65535h	0h	⊙

FR500F Series Special Purpose Inverter

	when previous fault occurred			
U01.10	Before-previous fault code	Same as U01.00	0	⊙
U01.11	Running frequency when before-previous fault occurred	0.00~Fup	0.00Hz	⊙
U01.12	Output current when before-previous fault occurred	0.0~3000.0A	0.0A	⊙
U01.13	Bus voltage when before-previous fault occurred	0~1200V	0V	⊙
U01.14	Cumulative running time when before-previous fault occurred	0~65535h	0h	⊙
U01.15	Previous 3 categories of faults	The same with U01.00	Err00	⊙
U01.16	Previous 4 categories of faults	The same with U01.00	Err00	⊙
U01.17	Previous 5 categories of faults	The same with U01.00	Err00	⊙
U01.18	Previous 6 categories of faults	The same with U01.00	Err00	⊙
U01.19	Previous 7 categories of faults	The same with U01.00	Err00	⊙
U01.20	Previous 8 categories of faults	The same with U01.00	Err00	⊙
U01.21	Previous 9 categories of faults	The same with U01.00	Err00	⊙
U01.22	Previous 10 categories of faults	The same with U01.00	Err00	⊙
U01.23	Previous 11 categories of faults	The same with U01.00	Err00	⊙
U01.24	Previous 12 categories of faults	The same with U01.00	Err00	⊙
U01.25	Previous 13 categories of faults	The same with U01.00	Err00	⊙

H00 Group: function parameters special for textile machine					Modbus Address
H00.00	Control of Textile Machine	0:Invalid 1:Valid	1	×	4000H
H00.01	Multi-steps 0	0.00~600.00Hz	0.00Hz	△	4001H
H00.02	Multi-steps 1	0.00~600.00Hz	0.00Hz	△	4002H
H00.03	Multi-steps 2	0.00~600.00Hz	0.00Hz	△	4003H
H00.04	Multi-steps 3	0.00~600.00Hz	0.00Hz	△	4004H
H00.05	Multi-steps 4	0.00~600.00Hz	0.00Hz	△	4005H
H00.06	Multi-steps 5	0.00~600.00Hz	0.00Hz	△	4006H
H00.07	Multi-steps 6	0.00~600.00Hz	0.00Hz	△	4007H
H00.08	Multi-steps 7	0.00~600.00Hz	0.00Hz	△	4008H
H00.09	Multi-steps 8	0.00~600.00Hz	0.00Hz	△	4009H
H00.10	Multi-steps 9	0.00~600.00Hz	0.00Hz	△	400AH
H00.11	Multi-steps 10	0.00~600.00Hz	0.00Hz	△	400BH
H00.12	Multi-steps 11	0.00~600.00Hz	0.00Hz	△	400CH

## FR500F Series Special Purpose Inverter

H00.13	Multi-steps 12	0.00~600.00Hz	0.00Hz	△	400DH
H00.14	Multi-steps 13	0.00~600.00Hz	0.00Hz	△	400EH
H00.15	Multi-steps 14	0.00~600.00Hz	0.00Hz	△	400FH
H00.16	Multi-steps 15	0.00~600.00Hz	0.00Hz	△	4010H
H00.17	Simple PLC 0 step running time/length	0.0~6000.0s/min/m	0.0s/min/m	△	4011H
H00.18	Simple PLC 1 <sup>st</sup> step running time/length	0.0~6000.0s/min/m	0.0s/min/m	△	4012H
H00.19	Simple PLC 2 <sup>nd</sup> step running time/length	0.0~6000.0s/min/m	0.0s/min/m	△	4013H
H00.20	Simple PLC 3 <sup>rd</sup> step running time/length	0.0~6000.0s/min/m	0.0s/min/m	△	4014H
H00.21	Simple PLC 4 <sup>th</sup> step running time/length	0.0~6000.0s/min/m	0.0s/min/m	△	4015H
H00.22	Simple PLC 5 <sup>th</sup> step running time/length	0.0~6000.0s/min/m	0.0s/min/m	△	4016H
H00.23	Simple PLC 6 <sup>th</sup> step running time/length	0.0~6000.0s/min/m	0.0s/min/m	△	4017H
H00.24	Simple PLC 7 <sup>th</sup> step running time/length	0.0~6000.0s/min/m	0.0s/min/m	△	4018H
H00.25	Simple PLC 8 <sup>th</sup> step running time/length	0.0~6000.0s/min/m	0.0s/min/m	△	4019H
H00.26	Simple PLC 9 <sup>th</sup> step running time/length	0.0~6000.0s/min/m	0.0s/min/m	△	401AH
H00.27	Simple PLC 10 <sup>th</sup> step running time/length	0.0~6000.0s/min/m	0.0s/min/m	△	401BH
H00.28	Simple PLC 11 <sup>th</sup> step running time/length	0.0~6000.0s/min/m	0.0s/min/m	△	401CH
H00.29	Simple PLC 12 <sup>th</sup> step running time/length	0.0~6000.0s/min/m	0.0s/min/m	△	401DH
H00.30	Simple PLC 13 <sup>th</sup> step running time/length	0.0~6000.0s/min/m	0.0s/min/m	△	401EH
H00.31	Simple PLC 14 <sup>th</sup> step running time/length	0.0~6000.0s/min/m	0.0s/min/m	△	401FH
H00.32	Simple PLC 15 <sup>th</sup> step running time/length	0.0~6000.0s/min/m	0.0s/min/m	△	4020H
H00.33	Simple PLC running mode	Unit's place: simple PLC running mode selection 0:single-cycle, and then stops 1:single-cycle, and then keep final value 2:continuous cycle	00000	×	4021H
		Ten's place: interrupt operation, and then start the selection 0: continue from stop step(restart moment) 1: continue from stop step and moment 2: re-operation starts from 0 step			



## FR500F Series Special Purpose Inverter

		Hundred's place: power-off memory selection 0: power-off no memory 1: power-off memory			
		Thousand's place: Simple PLC running time 0:s (second) 1:min (minute)			
		Ten thousand's place: Length unit 0:0.1m 1:1m			
H00.34	Running Mode	0: Linear mode 1: Gradual mode 2: Length mode	0	×	4022H
H00.35	Speed Ratio	0.00~600.00RPM/Hz	30.00RPM/ Hz	△	4023H
H00.36	Current Rev	0~60000RPM	0RPM	⊙	4024H
H00.37	Average Speed	0~60000RPM	0RPM	⊙	4025H
H00.38	Average Speed Hz	0.00~600.00Hz	0Hz	⊙	4026H
H00.39	Roller speed measurement	0:Calculated based on speed 1:Calculated based on pulse input(DI7)	0	×	4027H
H00.40	Roller diameter	0.0~6000.0mm	50.0mm	△	4028H
H00.41	Roller per revolution	0~100	1	△	4029H
H00.42	Current line speed	0.0~6000.0m/min	0.0m/min	⊙	402AH
H00.43	Completed length	0~60000m	0m	⊙	402BH
H00.44	Percent length completed	0.0~100.0%	0.0%	⊙	402CH

### 3.3 H00 Textile-specific function group explanation

H00.00	Control of Textile Machine	0:Invalid 1:Valid	1	×
--------	----------------------------	----------------------	---	---

0: Invalid

General inverter

1:Valid

Special purpose inverter for textile machine, H00 group valid.

H00.01	Multi-steps 0	0.00~600.00Hz	0.00Hz	△
H00.02	Multi-steps 1	0.00~600.00Hz	0.00Hz	△
H00.03	Multi-steps 2	0.00~600.00Hz	0.00Hz	△
H00.04	Multi-steps 3	0.00~600.00Hz	0.00Hz	△
H00.05	Multi-steps 4	0.00~600.00Hz	0.00Hz	△
H00.06	Multi-steps 5	0.00~600.00Hz	0.00Hz	△
H00.07	Multi-steps 6	0.00~600.00Hz	0.00Hz	△
H00.08	Multi-steps 7	0.00~600.00Hz	0.00Hz	△
H00.09	Multi-steps 8	0.00~600.00Hz	0.00Hz	△
H00.10	Multi-steps 9	0.00~600.00Hz	0.00Hz	△
H00.11	Multi-steps 10	0.00~600.00Hz	0.00Hz	△

## FR500F Series Special Purpose Inverter

H00.12	Multi-steps 11	0.00~600.00Hz	0.00Hz	△
H00.13	Multi-steps 12	0.00~600.00Hz	0.00Hz	△
H00.14	Multi-steps 13	0.00~600.00Hz	0.00Hz	△
H00.15	Multi-steps 14	0.00~600.00Hz	0.00Hz	△
H00.16	Multi-steps 15	0.00~600.00Hz	0.00Hz	△
H00.17	Simple PLC 0 <sup>th</sup> step running time/length	0.0~6000.0s/min/m	0.0s/min/m	△
H00.18	Simple PLC 1 <sup>st</sup> step running time/length	0.0~6000.0s/min/m	0.0s/min/m	△
H00.19	Simple PLC 2 <sup>nd</sup> step running time/length	0.0~6000.0s/min/m	0.0s/min/m	△
H00.20	Simple PLC 3 <sup>rd</sup> step running time/length	0.0~6000.0s/min/m	0.0s/min/m	△
H00.21	Simple PLC 4 <sup>th</sup> step running time/length	0.0~6000.0s/min/m	0.0s/min/m	△
H00.22	Simple PLC 5 <sup>th</sup> step running time/length	0.0~6000.0s/min/m	0.0s/min/m	△
H00.23	Simple PLC 6 <sup>th</sup> step running time/length	0.0~6000.0s/min/m	0.0s/min/m	△
H00.24	Simple PLC 7 <sup>th</sup> step running time/length	0.0~6000.0s/min/m	0.0s/min/m	△
H00.25	Simple PLC 8 <sup>th</sup> step running time/length	0.0~6000.0s/min/m	0.0s/min/m	△
H00.26	Simple PLC 9 <sup>th</sup> step running time/length	0.0~6000.0s/min/m	0.0s/min/m	△
H00.27	Simple PLC 10 <sup>th</sup> step running time/length	0.0~6000.0s/min/m	0.0s/min/m	△
H00.28	Simple PLC 11 <sup>th</sup> step running time/length	0.0~6000.0s/min/m	0.0s/min/m	△
H00.29	Simple PLC 12 <sup>th</sup> step running time/length	0.0~6000.0s/min/m	0.0s/min/m	△
H00.30	Simple PLC 13 <sup>th</sup> step running time/length	0.0~6000.0s/min/m	0.0s/min/m	△
H00.31	Simple PLC 14 <sup>th</sup> step running time/length	0.0~6000.0s/min/m	0.0s/min/m	△
H00.32	Simple PLC 15 <sup>th</sup> step running time/length	0.0~6000.0s/min/m	0.0s/min/m	△

H00.01-H00.16 corresponding to the frequency set of each speed, means to F0-F15;

H00.17-H00.32 corresponding to the running time/length set of each speed, means to T0-T15/L0-L15.

H00.33	Simple PLC running mode	Unit's place: simple PLC running mode selection 0:single-cycle, and then stops 1:single-cycle, and then keep final value 2:continuous cycle	00000	×
		Ten's place: interrupt operation, and then start the selection 0: continue from stop step(restart moment) 1: continue from stop step and moment 2: re-operation starts from 0 step		

		Hundred's place: Power-off memory selection 0: power-off no memory 1: power-off memory		
		Thousand's place: Simple PLC running time 0:s (second) 1:min (minute)		
		Ten thousand's place: Length unit 0:0.1m 1:1m		

Unit's place: simple PLC running mode selection

0:Single-cycle, and then stops

PLC stops automatically after finishing a cycle, restart available only after receiving restart command.

1:Single-cycle and then keep final value

PLC keeps the last speed running frequency and directions after finishing a cycle.

2:Continuous cycle

PLC automatically starts next cycle after finishing a cycle, until receiving the stop command.

Ten's place: Interrupt operation, and then start the selection

0: continue from stop step (restart moment)

Inverter stopped, automatically record the current step, and then automatically step into this step when restart, and continue running as the frequency specified by this step, time recalculate.

1: continue from stop step andmoment

Inverters stopped, automatically record the finished running time in current step, and then automatically step into this step when restart, and continue to running the remained time as frequency specified by this step.

2: re-operation starts from 0 step

Inverter restarts after stopping, running from step 0.

Hundred's place: power-off memory selection

0: power-off no memory

Inverter no memory of PLC running status when power-off, when power-on, restart and running from the first step.

1: power-off memory

Inverter has memory of PLC running status when power-off, include the power-off moment step and finished running time, when power-on, continue running according to the memory data.

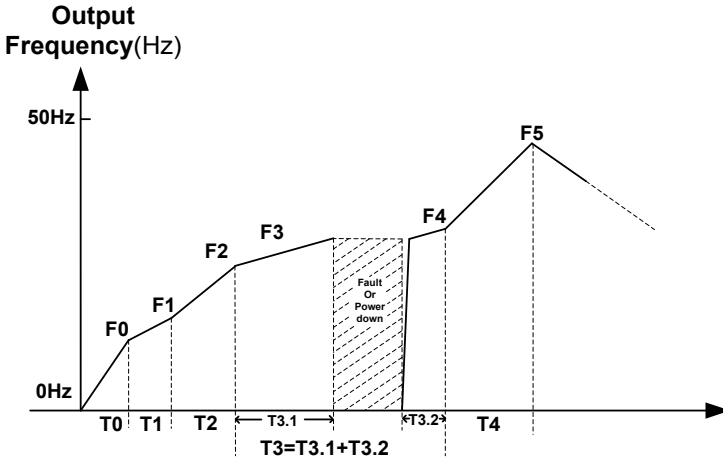

Figure 3-1 Power-off Memory Function

Thousand's place: Simple PLC running time

0:s (second)

1:min (minute)

Set unit of simple PLC running time.

Ten thousand's place: Set length unit

0: 0.1m

1: 1m

H00.34	Running Mode	0: Linear mode	0	×
		1: Gradual mode		
		2: Length mode		

0: Linear mode

Linear mode, when step into a speed, timing starts, and running to the step setting speed by acce/dece time, when arrive at the speed, inverter continue running as the speed until timing arrived at setting time.

Output Frequency(Hz)

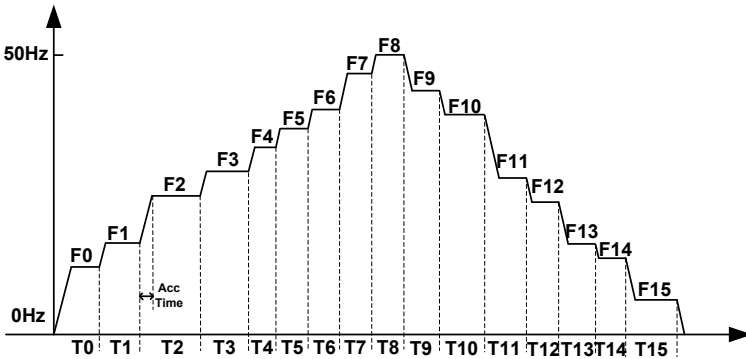

Figure 3-2 linear mode running diagram

1: Gradual Mode

Gradual mode, frequency gradually changed from current speed to next setting speed, total

consuming time is set time. When PLC running finished, inverter stops according to the dece time, running diagram as below:

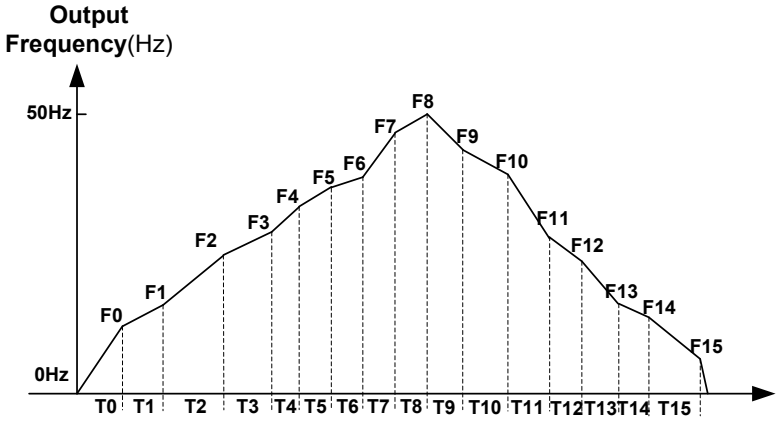
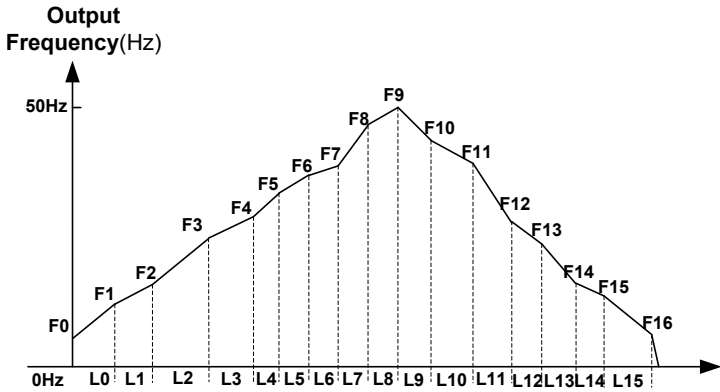

Figure 3-3 Gradual mode running diagram

2: Length mode

Frequency gradually changed from current speed to next setting speed, total consuming length is set length (Length is calculated according to current frequency or to pulse input). When PLC running finished, inverter stops according to the deceleration time, running diagram as below:



H00.35	Speed Ratio	0.00~600.00RPM/Hz	30.00RPM/Hz	△
--------	-------------	-------------------	-------------	---

The value use for set external machine ratate speed, which corresponds to inverter 1Hz.

H00.36	Current Rev	0~60000RPM	0RPM	⊙
--------	-------------	------------	------	---

Current rotate speed multipls H00.35 to get a value for machine rotate speed.

H00.37	Average Rev	0~60000RPM	0RPM	⊙
H00.38	Average Speed Hz	0.00~600.00Hz	0Hz	⊙

Average speed is the value calculated by every steps frequency and time,  
 Average speed Hz= $((F0*T0)+(F1*T1)+...+(F15*T15))/(T0+T1+...+T15)$

# FR500F Series Special Purpose Inverter

Average rev = Average speed Hz\*H00.35

H00.39	Roller speed measurement	0: Calculated based on speed 1: Calculated based on pulse input(DI7)	0	×
H00.40	Roller diameter	0.0~6000.0mm	50.0mm	△
H00.41	Roller per revolution	0~100	1	△
H00.42	Current line speed	0.0~6000.0m/min	0.0m/min	⊖

This function code(H00.39) is used to set the measurement method of roller speed.

0: Calculated based on speed

According to current frequency, estimated the current speed.

$$\text{Current line speed(m/min)} : \text{current line speed} = \frac{\text{current freq} \cdot \text{MaxSpeed}}{\text{MaxFrq}} * \text{Roller diameter} * \frac{\text{Pi}}{1000};$$

1: Calculated based on pulse input(DI7).

According to practical pulse input, calculated the current Roller speed.

$$\text{Current line speed(m/min)}: \text{current line speed} = \frac{\text{pulse num per min}}{\text{Roller per revolution}} * \text{Roller diameter} * \frac{\text{Pi}}{1000};$$

H00.43	Completed length	0~60000m	0m	⊖
H00.44	Percent length completed	0.0~100.0%	0.0%	⊖

H00.43 shows the current completed length.

H00.44 shows the percent length completed: percent = H00.43/(L0+L1+L2....+L15);

## Chapter 4 Maintenance and Troubleshooting

FR500F series inverter provide a number of warning information and protection, when a fault occurs, the protective function actions, the inverter will stop output, inverter fault relay contact actions, and the inverter displays fault code on its display panel. Before asking for service, user can do the self-examination tips according to this section, analyze fault reason, and find solutions. If the fault still cannot be solved, pls ask for services, or contact the dealer who sold you inverter, or directly contact our company.

Display	Fault Name	Possible Troubleshooting	Fault Solutions
Err01	Acce overcurrent	1: The output circuit is grounded or short circuited. 2: The acceleration time is too short. 3: Manual torque boost or V/F curve is not appropriate. 4: The voltage is too low. 5: The startup operation is performed on the rotating motor. 6: A sudden load is added during acceleration. 7: The AC drive model is of too small power class.	1: Eliminate external faults. 2: Increase the acceleration time. 3: Adjust the manual torque boost or V/F curve. 4: Adjust the voltage to normal range. 5: Select rotational speed tracking restart or start the motor after it stops. 6: Remove the added load. 7: Select an AC drive of higher power class
Err02	Dece overcurrent	1: The output circuit is grounded or short circuited. 2: The deceleration time is too short. 3: The voltage is too low. 4: A sudden load is added during deceleration. 5: The braking unit and braking resistor are not installed.	1: Eliminate external faults. 2: Increase the deceleration time. 3: Adjust the voltage to normal range. 4: Remove the added load. 5: Install the braking unit and braking resistor.
Err03	Constant-s peed overcurrent	1: The output circuit is grounded or short circuited. 2: The voltage is too low. 3: A sudden load is added during operation. 4: The AC drive model is of too small power class.	1: Eliminate external faults 2: Adjust the voltage to normal range. 3: Remove the added load 4: Select an AC drive of higher power class.
Err04	Acce overvoltage	1: The input voltage is too high. 2: An external force drives the motor during acceleration. 3: The acceleration time is too short. 4: The braking unit and braking resistor are not installed.	1: Adjust the voltage to normal range. 2: Cancel the external force or install a braking resistor. 3: Increase the acceleration time. 4: Install the braking unit and braking resistor.
Err05	Dece overvoltage	1: The input voltage is too high. 2: An external force drives the motor during deceleration. 3: The deceleration time is too short.	1: Adjust the voltage to normal range. 2: Cancel the external force or install the braking resistor. 3: Increase the deceleration time. 4: Install the braking unit and

## FR500F Series Special Purpose Inverter

		4: The braking unit and braking resistor are not installed.	braking resistor.
Err06	Constant-speed overvoltage	1: The input voltage is too high 2: An external force drives the motor during deceleration.	1: Adjust the voltage to normal range. 2: Cancel the external force or install the braking resistor.
Err07	Bus undervoltage Protection	1: Instantaneous power failure occurs on the input power supply. 2: The AC drive's input voltage is not within the allowable range. 3: The bus voltage is abnormal. 4: The rectifier bridge and buffer resistor are faulty. 5: The drive board is faulty. 6: The main control board is faulty.	1: Reset the fault. 2: Adjust the voltage to normal range. 3: Contact the agent or Frecon.
Err08	Short circuit Protection	1: The output circuit is grounded or short circuited. 2: The connecting cable of the motor is too long. 3: The module overheats. 4: The internal connections become loose. 5: The main control board is faulty 6: The drive board is faulty. 7: The inverter module is faulty.	1: Eliminate external faults. 2: Install a reactor or an output filter. 3: Check the air filter and the cooling fan. 4: Connect all cables properly. 5: Contact the agent or Frecon.
Err09	Input phase loss	1: The three-phase power input is abnormal. 2: The drive board is faulty. 3: The lightning board is faulty. 4: The main control board is faulty.	1: Eliminate external faults. 2: Contact the agent or FRECON.
Err10	Output phase loss	1: The cable connecting the AC drive and the motor is faulty. 2: The AC drive's three-phase outputs are unbalanced when the motor is running. 3: The drive board is faulty. 4: The module is faulty.	1: Eliminate external faults. 2: Check whether the motor Three-phase winding is normal. 3: Contact the agent or Frecon.
Err11	Motor Overload	1: F11-17 is set improperly. 2: The load is too heavy or locked-rotor occurs on the motor. 3: The AC drive model is of too small power class.	1: Set F11-17 correctly. 2: Reduce the load and check the motor and the mechanical condition. 3: Select an AC drive of higher power class.
Err12	Inverter overload	1: The load is too heavy or locked-rotor occurs on the motor. 2: The AC drive model is of too	1: Reduce the load and check the motor and mechanical condition. 2: Select an AC drive of higher



FR500F Series Special Purpose Inverter

		small power class.	power class.
Err13	External Input fault protection	1: External fault signal is input via DI.	Reset running
Err14	Overheat	1: The ambient temperature is too high. 2: The air filter is blocked. 3: The fan is damaged. 4: The thermally sensitive resistor of the module is damaged. 5: The inverter module is damaged.	1: Lower the ambient temperature. 2: Clean the air filter. 3: Replace the damaged fan. 4: Replace the damaged thermally sensitive resistor. 5: Replace the inverter module.
Err15	EEPROM read/write fault	The EEPROM chip is damaged.	Replace the main control board.
Err16	Motor auto-tuning cancelled	Since the identification process, press STOP / RST key	Press STOP / RST key to reset
Err17	Motor auto-tuning fault	1: the motor and the inverter output terminals are not connected 2: The motor does not disengage the load 3: The electrical fault	1: check the connection between the inverter and motor 2: The motor is disengaged load 3: Check the motor
Err18	Communication overtime error	1: The PC is not working properly 2: The communication line is not normal 3: F15 set communication parameters set incorrectly	1: Check the PC Connection 2: Check the communication cable 3: The communication parameters are set correctly
Err19	PID feedback loss	PID feedback set value is less than F13.24	Check the PID feedback signal or set to an appropriate value F13.24
Err20	Continuous running time Reached	Set the running time to reach this function	reference F05.14 Description
Err21	Parameter upload fault	1: Is not installed or is not plugged parameter copy card 2: Parameter copy card anomalies 3: The control board abnormalities	1: a copy of the card is properly installed parameters 2: for technical support 3: for technical support
Err22	Parameter download fault	1: Is not installed or is not plugged parameter copy card 2: Parameter copy card anomalies 3: The control board abnormalities	1: A copy of the card is properly installed parameters 2: For technical support 3: For technical support
Err23	Braking unit fault	1: The brake line failure or damage the brake pipe 2: An external braking resistor is too small	1: Check the brake unit, replace the brake pipe 2: Increasing the braking resistor
Err24	Module temperature detection disconnect	The temperature sensor failure or cable break	For technical support

## FR500F Series Special Purpose Inverter

	on		
Err25	Load becoming 0	The AC drive running current is lower than F11.22	Check that the load is disconnected or the setting F11-22 and F11-23 is correct.
Err26	With-wave current limit fault	1: The load is too heavy or locked rotor occurs on the motor. 2: The AC drive model is of too small power class.	1: Reduce the load and check the motor and mechanical condition. 2: Select an AC drive of higher power class.
Err27	Inverter soft-start relay is off	1: The grid voltage is too low 2: Rectifier module failure	1: Check the grid voltage 2: Demand for technical support
Err28	Software version compatibility fault	1: The upper and lower transmission module parameters in the parameter version of the control panel version mismatch.	re-upload module parameters to pass down
Err29	Instantaneous overcurrent	1. Inverter output circuit being grounded or short-circuit; 2. The acceleration and deceleration time is too short; 3. Manually torque boost or V/F curve not appropriate; 4. Voltage too low; 5. Start the running motor; 6. Sudden-load in the acceleration process; 7. Model selection of inverter power is too small.	1. Troubleshooting peripheral problems; 2. To increase the acceleration time; 3. Adjust the manually torque boost or V/F curve; 4. Adjust the voltage to normal range; 5. Select RPM track start or start after motor stopped; 6. Cancel sudden-load; 7. Select the inverter with larger power.
Err30	Instantaneous overvoltage	1: Input voltage is too high; 2. There is external force drag the motor to run in deceleration process; 3. The deceleration time is too short; 4. No installation of braking resistor.	1: Adjust the voltage to normal range; 2. Cancel external force or install brake resistor; 3. To increase the deceleration time; 4. Install braking resistor
Err39	Motor temperature too high	1. PTC sensor configuration not right 2. Motor temperature protection value too small 3. Motor temperature too high	1. Reset PTC sensor parameter 2. Increase motor temperature protection value 3. Waiting until motor is cooled
Err40	The setting running time ends	1. Running time more than F00.25	1. Contact the dealer
Err41	Overload warning	1, when F11.18 = 00100 and the current output amp is more than F11.19	1, Check the current load